

Control Valves and Components for
Process, Wellhead and Safety Shutdown Systems

VERSA[®]

BULLETIN
B316 2016



www.versa-valves.com

e-mail: sales@versa-valves.com

Versa Products Company, Inc., 22 Spring Valley Road, Paramus, New Jersey 07601 • TEL: 201/843-2400 Fax: 201/843-2931
Versa BV., Prins Willem Alexanderlaan 1429, 7312 GB Apeldoorn, The Netherlands • TEL: +01131-55-3681900 FAX: +01131-55-3681909



QUALITY IS ABSOLUTE

Quality has no degrees at Versa. There is no such thing as “pretty good” or “almost right”. Every product is designed and manufactured to conform to uniformly high standards.

These standards are assured by a quality management system which includes ISO 9001 certification and testing of all products prior to shipment.



THE COMMITMENT CONTINUES

Fluid Power is our business. It is our only business, so we have to be good at it. Since its beginning in 1949, Versa has maintained its commitment to quality products and satisfied customers.

Versa has succeeded in serving industry’s needs with a broad line of directional control devices. Our focus on product variety, technical expertise and company support remains constant. It all begins with a responsiveness to industry needs and ends with delivery of the valve or system you need—when you need it.

We view ourselves as problem solvers and that role requires more than making good products. It is what we do before and after that is equally important. From drawing board to user satisfaction, our commitment is continuous.

No matter how tough the application or environmental demands, Versa offers you a choice of valves to meet the challenge. Advanced design, durable construction materials and rigid manufacturing standards provide valves you can rely on for years of trouble-free performance.

Be it a single valve or a pneumatic system, Versa’s commitment to quality is uncompromising. Count on it.

HOW WE PUT IT TOGETHER IS WHAT SETS US APART

Versa is not the biggest manufacturer of directional control valves, so we try to be the best.

Design, manufacture, quality control, pricing, delivery - whatever the function - it must be geared to customer needs.

Many companies sell valves. At Versa we sell satisfaction.

WORLDWIDE ACCESSIBILITY

More than 1000 fluid power representatives and over 100 stocking locations comprise Versa’s worldwide distribution system. They are supported by manufacturing and technical centers in the United States and The Netherlands.

The distributor network is the key to customer service and the source of continuous application feedback. Versa uses this input as part of its research and development program in an effort to respond to individual and industry needs.

Versa makes certain that our distributors’ sales and service personnel receive factory training on an ongoing basis. This includes basic theory, product indoctrination and seminars.

Our distributor family is a source of pride to Versa—but more important—it is a source of support and service to all of our customers.

Contact Versa for the distributor servicing your specific area.



Versa exercises diligence to assure that information contained in this catalog is correct, but does not accept responsibility for any errors or omissions. Versa also reserves the right to change or delete data or products at any time without prior notification. To be sure the data you require is correct, consult factory.



This Catalog Covers... SERIES **B** ³¹⁶ (Three-way Valves) ⁵⁵⁰ (Indicating Relay Valves) ⁹⁰⁰ (Main Supply Reset & Indicating Relay Valves)
and
Manual Shut-Off Valves

CONTENTS GUIDE

Series B316 Three-Way Valves (3/2) Page 4-14

General Description

The B316 Series is a complete line of compact, rugged Three-Way (3/2), side-ported valves, constructed of 316 stainless steel (conforms to NACE standard MR-01-75). They are designed for use particularly in corrosive environments and to control a variety of aggressive media as well as air. O ring packed poppets provide bubbletight sealing throughout the operating pressure range and when used to operate small volume appliances this feature conserves valuable instrument air.

Actuations include solenoid/pilot (including those suitable for Ordinary, Hazardous or LOW-WATT service), remote pressure pilot, manual, and mechanical. Many combination actuators and special function types can also be provided. Consult the factory for these items.

Solenoid actuated valves can be 2-position, single or double solenoid. A manual override option is available for most types.

Remote pressure pilot models can be 2-position, single or double pilot.

Manually actuated valves are 2-position, push button panel mounting types and are offered with or without guarded push buttons. An optional lid knob operated type is also available.

Mechanically actuated valves are 2-position and are supplied with a roller for cam interface.



Series B900 Main Supply Reset & Indicating Relay Valves Page 16-21

General Description

The B900 Series is comprised of Three-Way (3/2) Manual/Pilot Operated Main Supply Reset valves and Three-Way (3/2) Indicating Relay valves. All are constructed of 316 stainless steel (meets NACE standard MR-01-75). They are designed for use particularly in corrosive environments and to control aggressive media as well as air. O ring packed poppets provide bubbletight sealing throughout the operating range and when used to operate small volume appliances this feature saves valuable instrument air.

Main Supply Reset valves can function as master relay valves and are generally pilot operated-spring return, 2-position valves that are provided additionally with a means of manual operation. The function of the Main Supply Reset valve is to control the supply of pressure to a system or portion of a system. If a problem is sensed at some point in the system, the Main Supply Reset valve will shift to dump system pressure from that portion of the circuit controlled by that Main Supply Reset valve. The shifting of the Main Supply Reset valve is accomplished by a pilot device which is an integral part of the valve. The pilot is pressurized when the system is running normally, but when a problem is sensed, the pilot is depressurized and the valve shuts off the pressure to the main system or that portion of the main system that the valve controls. Several variations of reset are available. One example is a "latching pilot" whereby when pilot pressure returns, the valve will not shift to open the supply to the main system until the valve is manually reset. The manual portion of the reset can also be latching or non-latching. Most Main Supply Reset valves can also be equipped with an integral visual indicator that indicates when pressure is present in the pilot chamber. Complete functional descriptions of each valve can be found on the pages within this valve series.

Indicating Relay valves are of the First Out-Receiving or First Out-Transmitting type. They have two functions generally. First, to indicate visually on a panel that a circuit malfunction has occurred and secondly, to quickly exhaust operating pressure from the system through the Main Supply Reset valve.

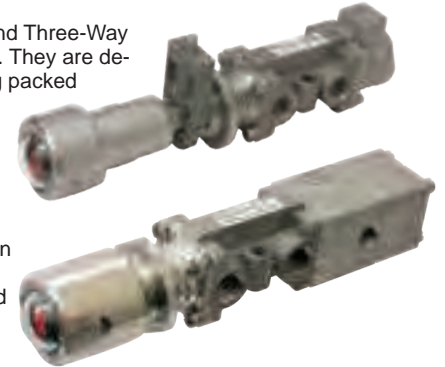

Series B500 Indicating Relay ValvesPage 21-22

General Description

The B550 Series Indicating Relay valves are Three-Way (3/2) First Out Indicating valves. They are of the First Out-Receiving type, First Out-Transmitting type or First Out-Bypass type. All are constructed of hard coated aluminum (MIL-A-8625E, Type III, Class 1) to provide reasonable resistance to extreme environmental conditions. Bubbletight sealing, accomplished by employing wafer seals, conserves valuable instrument air throughout the operating pressure range.

First out Indicating Relay valves have two functions. First, to indicate visually on a panel that a circuit malfunction has occurred and secondly, to quickly exhaust operating pressure from the system through the Main Supply Reset valve. The Indicating Relay valve with the Bypass function additionally provides the means to bypass the specific malfunctioning circuit without shutting down associated circuits.



Manual Shut-Off Valves Page 15

General Description

For emergency shut down systems a Two-Way Manual Bleed valve and a Three-Way Manual Block & Bleed valve are available. Both valves are constructed of 316 stainless steel (meets NACE standard MR-01-75), and may be used as panic valves to quickly depressurize the system in order to get immediate shut down.

The Two-Way Manual Bleed valve is closed during normal operation, but manual actuation or back-pressure to the outlet port will dump system pressure to atmosphere.

The Three-Way Manual Block & Bleed valve connects the inlet to the outlet during normal operation. Manual actuation or back-pressure to the exhaust port causes the inlet to be blocked while the outlet dumps system pressure to atmosphere.



SERIES B316 VALVES

STAINLESS STEEL CONSTRUCTION

3-WAY VALVES

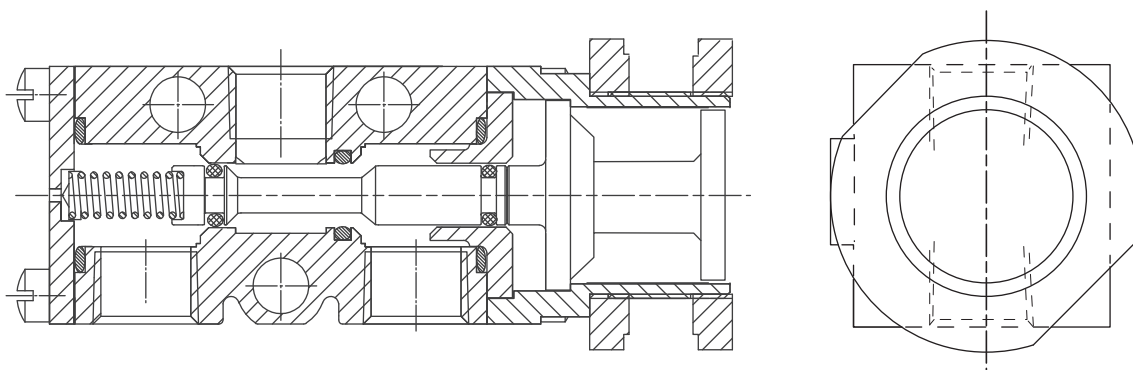

Construction

Versa B316 Valves are spool poppet valves except for double pilot and double solenoid valves which have balanced spools. Standard size O ring seals, placed in accordance with Versa's Anti-Extrusion principle provides long trouble free service with little and easy maintenance.

Materials

- Valve body and actuating caps: 316 stainless steel
- All internal wetted metal parts: 316 stainless steel NACE approved materials (solenoid parts not NACE approved)
- Valve Seals: FKM (fluorocarbon) O ring seals used as standard
- Screws: stainless steel

Porting and Flow

- Valve ports are 1/4" NPT; Pilot and solenoid ports are 1/8" NPT
- Flow area (orifice) is 0.196" (5mm)
- Cv (Kv) normally closed = 1.6 (23.2); normally open = 1.1 (16.0)

Pressure and Media

- 0 to 200 psig (14 bar); Air or Hydrocarbon gases or other gases compatible with materials used.
- Pressures for Pilot, or Solenoid/Pilot, or Manual & Pilot Combination operated valves - see pages pertaining to specific valve.

Electrical

See pages 8 to 14

Temperature Range

Solenoid Valves: The table below lists suggested suffix options for various temperature ranges and/or types of service. For temperatures or conditions not listed, consult factory.

Manual, Mechanical, Pilot Valves: -10°F (-23°C) to 200°F (95°C).

Temperature Range (Medium/Ambient Temperature)	TYPE OF SERVICE					
	Intermittent Duty Service		Continuous Duty Service			
	AC or DC		AC		DC	
	Coil	Solenoid Plunger*	Coil	Solenoid Plunger*	Coil	Solenoid Plunger*
150°F to 200°F (65°C) (95°C)	Suffix -HT	Suffix-3 (may be inclusive in other suffix options as it is in -HT)	Suffix -HT	Suffix-3 (may be inclusive in other suffix options as it is in -HT)	Suffix -HT	Suffix-3 (may be inclusive in other suffix options as it is in -HT)
120°F to 150°F (50°C) (65°C)	Standard	Suffix-3 (may be inclusive in other suffix options)	Standard	Suffix -3 (may be inclusive in other suffix options)	Suffix -HT	Suffix -3 (may be inclusive in other suffix options as it is in -HT)
-10°F to 120°F (-23°C) (50°C)	Standard	Standard	Standard	Suffix -3 (may be inclusive in other suffix options)	Standard	Suffix -3 (may be inclusive in other suffix options)

* All solenoids for hazardous locations include suffix -3 as standard.

Installation, Filtration & Lubrication

Valves have no limitations on mounting orientation.

40-50 micron filtration recommended.

General purpose lubricating oil ISO, ASTM viscosity grade 32 recommended.

Manually Operates Valves

For palm, finger, knee or straight-line mechanical operation. Can also be cam actuated if cam rise is gradual. Unguarded type has button exposed above valve body approximately 1/8", which is distance required for full actuation. Guarded type has

button flush with the button guard to protect against accidental actuation. Nominal operating force is 3.75 lbs. + .05 times line pressure (or 3.25N x bar line pressure + 17N).

DIMENSIONS: Inch
mm

3/2-(Three-Way) Valves



Button Operated (Guarded)/ Spring Return

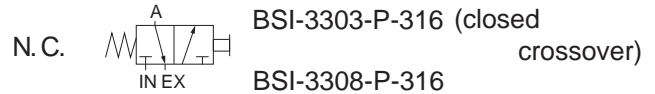
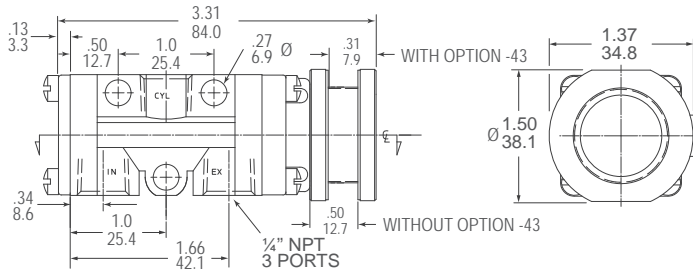

Button Operated (Unguarded)/ Spring Return

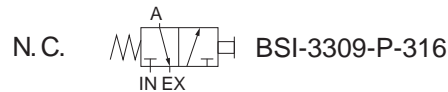
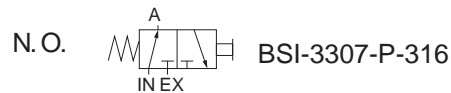
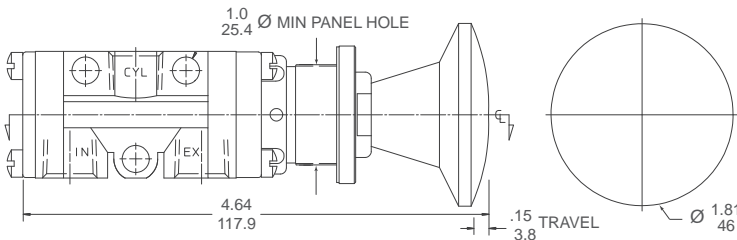

Suffix Options:

- 43E Additional panel mount nut for flush front mounting
- S Strong spring for applications with marginal lubrication; use requires 45% additional force to operate.
- 294B Rubber button cover

- S-25B Black plastic lid knob
- S-25G Green plastic lid knob
- S-25R Red plastic lid knob

Palm Button Operated/ Spring Return*

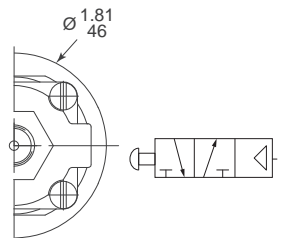
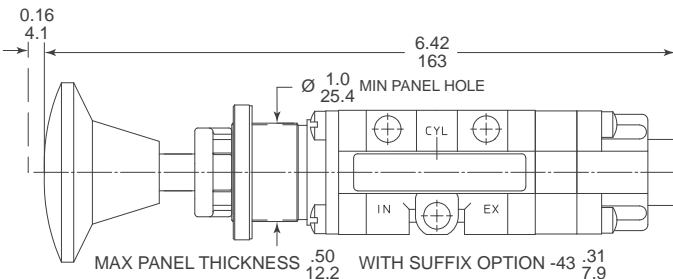

- BIP-3303-316 (closed crossover)
- BIP-3309-316

*Pilot pressure req. 15-200 psi (1-14 bar)

Suffix Options:

- 43E Additional panel mount nut for flush front mounting

- 25B Black plastic lid knob
- 25G Green plastic lid knob
- 25R Red plastic lid knob

SERIES B316 VALVES

STAINLESS STEEL CONSTRUCTION

Pilot Operated Valves

Controlled by a pressure signal applied to a small integral pilot piston that actuates the valve.

Pilot medium can be other than medium being controlled.

3/2-(Three-Way) Valves

DIMENSIONS: Inch
mm

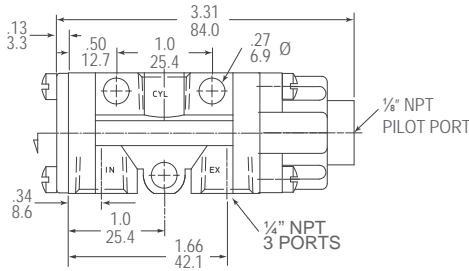

Pilot Operated/Spring Return

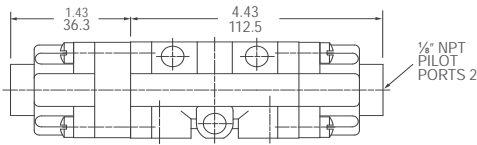
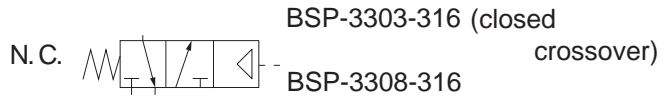
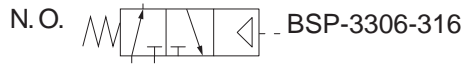

Pilot Operated/Pilot Return: (detented)

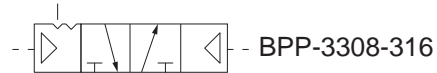

Pilot Operated Spring Return		Controlled (inlet) Pressure																			
		psi	bar	psi	bar	psi	bar	psi	bar	psi	bar	psi	bar	psi	bar	psi	bar	psi	bar		
BSP	Minimum pilot required	18	1.25	20	1.4	22	1.5	24	1.7	26	1.8	28	2.0	30	2.15	32	2.3	34	2.5	36	2.5
BPP		15 - 200psi (1 - 14 bar)																			

Mechanically Operated Valves

3/2-(Three-Way) Valves



Can be operated by a cam or machine member from any angle, but pressure angle should not exceed 15° from vertical center line.

Cam Operated/Spring Return

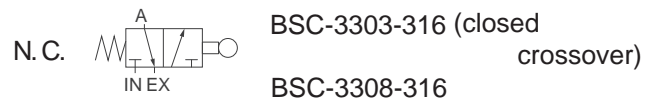
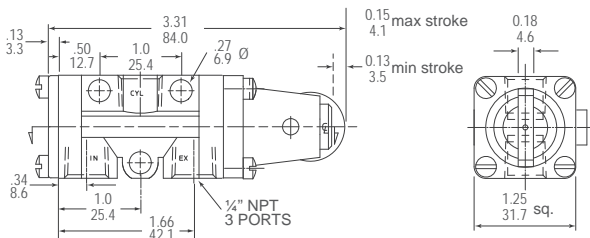

Hazardous Location Combination Suffix Details Cross Reference Chart

Suffix Reference	
Suffix	Description
-XX	North American solenoid
-XN	ATEX solenoid
-XDB	World Solenoid
-HT	Class H coil
-ST	Stainless solenoid housing
-PC	Potted coil
-LB	1.8 watt solenoid
-LA	0.85 watt solenoid
-VJBT	Add on Junction Box
-D14	Solenoid vent, water proof nut
-PS	Potted coil, male conduit
-CD	72" wire leads
-LX	1.8 watt solenoid
-H2E	1/8" npt solenoid vent
-HE	1/4" npt solenoid vent
-L14	solenoid vent dust nut
-303D	Integral diode

North American (-XX)	
Combination Suffix	Included Suffix
-XXA	-XX, -HT
-XXA4	-XX, -D14, -HT
-XXB	-XX, -PS
-XXB4	-XX, -D14, -PS
-XXC	-XX, -HT, -PS
-XXC4	-XX, -D14, -HT, -PS
-XXD	-XX, -ST
-XXD4	-XX, -D14, -ST
-XXE	-XX, -PC, -ST
-XXE4	-XX, -D14, -PC, -ST
-XXF	-XX, -HT, -ST
-XXF4	-XX, -D14, -HT, -ST
-XXG	-XX, -LB, -ST
-XXG4	-XX, -D14, -LB, -ST
-XXH	-XX, -HT, -PC, -ST
-XXJ	-XX, -LB, -PC, -ST
-XXJ4	-XX, -D14, -LB, -PC, -ST

North American (-XX) (Cont.)	
Combination Suffix	Included Suffix
-XXX	-XX, -HT, -LB, -PC, -ST
-XXX4	-XX, -D14, -HT, -LB, -PC, -ST
-XXL	-XX, -PC
-XXL4	-XX, -D14, -PC
-XXM	-XX, -HT, -PC
-XXM4	-XX, -D14, -HT, -PC
-XXN	-XX, -LB, -PC
-XXN4	-XX, -D14, -LB, -PC
-XXP	-XX, -HT, -LB, -PC
-XXP4	-XX, -D14, -HT, -LB, -PC
-XXQ	-XX, -HT, -LB
-XXQ4	-XX, -D14, -HT, -LB
-XXR	-XX, -LB
-XXR4	-XX, -D14, -LB
-XXS	-XX, -LA, -ST
-XXS4	-XX, -D14, -LA, -ST
-XXU	-XX, -HT, -LB, -ST
-XXU4	-XX, -D14, -HT, -LB, -ST
-XXV	-XX, -LA
-XXV4	-XX, -D14, -LA
-XXW	-XX, -CD, -HT, -H2, -PC, -ST
-XXW4	-XX, -D14, -CD, -HT, -PC, -ST

ATEX (XN)	
Combination Suffix	Included Suffix
-XNA	-XN, -HT
-XND	-XN, -ST
-XNE	-XN, -PC, -ST
-XNE4	-XN, -D14, -PC, -ST
-XNF	-XN, -HT, -ST
-XNG	-XN, -LB, -ST
-XNH	-XN, -HT, -PC, -ST
-XNJ	-XN, -LB, -PC, -ST
-XNJ4	-XN, -D14, -LB, -PC, -ST
-XNK	-XN, -HT, -LB, -PC, -ST
-XXK4	-XN, -D14, -HT, -LB, -PC, -ST
-XNL	-XN, -PC

ATEX (XN) (Cont.)	
Combination Suffix	Included Suffix
-XNL4	-XN, -D14, -PC
-XNM	-XN, -HT, -PC
-XNN	-XN, -LB, -PC
-XNN4	-XN, -D14, -LB, -PC
-XNP	-XN, -HT, -LB, -PC
-XNQ	-XN, -HT, -LB
-XNR	-XN, -LB
-XNS	-XN, -LA, -ST
-XNS4	-XN, -D14, -LA, -ST
-XNU	-XN, -HT, -LB, -ST
-XNV	-XN, -LA
-XNV4	-XN, -D14, -LA
-XNX	-XN, -LB, -PS
-XNWS	-XN, -VJBT, -LB, -PS

World Solenoid (XDB)	
Combination Suffix	Included Suffix
-XDBS1	-XDBS, -HT, -LX
-XDBS2	-XDBS, -HT, -LX, -H2E
-XDBS3	-XDBS, -HT, -LX, -HE
-XDBS4	-XDBS, -HT, -LX, -L14
-XDBS5	-XDBS, -HT, -LX, -303D
-XDBS6	-XDBS, -HT, -LX, -H2E, -303D
-XDBS7	-XDBS, -HT, -LX, -HE, -303D
-XDBS8	-XDBS, -HT, -LX, -L14, -303D
-XDBS9	-XDBS, -HT, -LX, -D14
-XDBS10	-XDBS, -HT, -LX, -D14, -303D
-XDBT1	-XDBT, -HT, -LX
-XDBT2	-XDBT, -HT, -LX, -H2E
-XDBT3	-XDBT, -HT, -LX, -HE
-XDBT4	-XDBT, -HT, -LX, -L14
-XDBT5	-XDBT, -HT, -LX, -303D
-XDBT6	-XDBT, -HT, -LX, -H2E, -303D
-XDBT7	-XDBT, -HT, -LX, -HE, -303D
-XDBT8	-XDBT, -HT, -LX, -L14, -303D
-XDBT9	-XDBT, -HT, -LX, -D14
-XDBT10	-XDBT, -HT, -LX, -D14, -303D

Recommended Hazardous Location Solenoid Option Packages

(For complete specifications please see above and page 8)

Enclosure/Wire	Certification/Power			
	North American - CSA		ATEX - IECEx - INMETRO	
	Standard Power	Low Watt*	Standard Power	Low Watt*
Steel, Electroless Nickel Plated, 24 Inch Leads	-XXL4	-XXN4	-XNL4	-XNN4
Stainless Steel, High Performance 430 type, 24 Inch leads	-XXE4	-XXJ4	-XNE4	-XNJ4
Stainless Steel, 316L type, Junction Box with Terminal Strip	n/a	-XDBT9**	n/a	-XDBS9

* 1.8 watt solenoid. Also available is 0.85 watt, see cross reference chart above. For 0.50 watt, consult factory.

** All the -XDBT type solenoids are "World Solenoids." Certified for North America, ATEX, IECEx and INMETRO



SERIES B316 VALVES

STAINLESS STEEL CONSTRUCTION

Solenoid/Pilot Operates Valves- 3/2-(Three-Way) Valves

Solenoid-Pilot actuated Series B316 valves are available with a variety of different solenoids for both nonhazardous and hazardous locations. Basic details of actuators are listed below. For additional data consult factory.

Non Hazardous Locations Solenoids

	Suffix Identification	Protection Classification	Area Classification and (Gas Grouping)	Certification-(Conformance)	Ingress Protection
	None or -HT, PC	General Purpose	Indoor & Outdoor	CSA	NEMA 1,2, 3 & 4
	-HC -HCC (Shown)	General Purpose	Indoor & Outdoor	CSA	NEMA 4; IP65

HAZARDOUS LOCATION OPERATORS

	Suffix Identification	Protection Classification	Area Classification and (Gas Grouping)	Certification-(Conformance)	Ingress Protection
	-XX	Hazardous Locations	CLASS I, DIV. 2 (A & B) CLASS I, DIV. 1 (C & D) CLASS II, DIV. 1 (E, F & G)	UL - CSA	NEMA 7 & 9
	-LB-XX				
See page 4 for recommended options					
	-XN	(d) Flameproof	Ex d IIB+H2 T3 to T6 Gb II 2 G Ex d IIB+H2 T3 to T6	IECEX	P65 & IP66
	-LB-XN			IECEX ATEX	
See page 4 for recommended options					
	-XDBS* -XDBT*	(d) Flameproof (e) Increased Safety	EX II 2 G D Ex d e IIC T* Gb EX tb IIIC T* °C Db Class I Div I Grp B, C & D Class I Div II Grp E, F & G EX d IIC DIP A21 T6 T4	ATEX IECEX -INMETRO CSA	IP66, IP67, & IP68
See page 4 for recommended options					
	-XMAA -XMAE -XMAF -XMAG -XMFA -XMFE -XMFF -XMFG	(mb) Encapsulation (e) Increased Safety (tD) Tight Dust	Ex e mb II T5, T6 Gb Ex tD A21 T100°C, T85°C Db II 2 G Ex e mb II T5, T6 II 2D Ex tD A21 T100°C, T85°C	IECEX ATEX	IP66 & IP67
	-XIFA -XIFE -XIFF	(ia) Intrinsic Safe	Ex (ia) IIC T4...T6 Gb Ex (ia) IIIC T130°C, T80°C Db II 2 G Ex ia IIC T4...T6 II 2 D Ex iaD 21 T130°C, T80°C	IECEX	IP66 & IP67
				ATEX	
	-XISX6		II 2 G EEx ia IIC T6	ATEX	IP65
	-XISC	Intrinsic Safe	Class I, Groups (A, B, C & D) Class II, Groups (E, F, & G) Class III	Factory Mutual CSA	

* -U (up right coil cap) Recommended for use with -XDB_, -XMA_, -XMF_ & XIF_ coils on NAMUR valves for mounting clearance. See page 8 for dimensions.

PRODUCT NUMBER COIL CODES: Complete product numbers require, when applicable, a coil code that represents the desired coil current type, frequency and voltage. The coil code takes the form shown below, with ratings and voltage substituted as required.

Voltage (Power)	Electrical Characteristics	Miscellaneous																																		
All usual 50 Hz & 60 Hz AC (6W) All usual DC (7W)	Class F epoxy molded coil (155°C). Continuous duty, 2 leads 24" (60 cm).	Steel cover with 1/2 NPT conduit entry.																																		
24V60, 120V60, 240V60 (8.5W) 24V50, 110V50, 220V50 (8.5W) 12VDC, 24VDC, 48VDC (10.5W)	Class F epoxy molded coil (155°C), with 3 spade terminals. Continuous duty.	Mini DIN socket with PG9 cable gland (-HC) or 1/2" conduit connection (-HCC).																																		
Voltage (Power)	Electrical Characteristics	Miscellaneous																																		
All usual 50 Hz & 60 Hz AC (5.6W) All usual DC (7.2W)	Class F epoxy molded coil (155°C). Continuous duty. 3 leads 24" (60 cm).	Plated steel coil housing with 1/2 NPT conduit entry. For stainless steel (430 type) coil housing add: (-ST)																																		
12V60, 24V60, 48V60, 120V60, 240V60 (1.8W) 6VDC, 12VDC, 24VDC, 48VDC (1.8W)		Plated steel coil housing with 1/2 NPT conduit entry. For stainless steel (430 type) coil housing add: (-ST) Maximum pilot pressure 120 psi (8 bar) 1.8W nominal power.																																		
All usual 50 Hz & 60 Hz AC (5.6W) All usual DC (7.2W)		Plated steel coil housing with M20 x 1.5 conduit entry. Ground terminal on cover. For stainless steel (182FM) coil housing add: (-ST)																																		
12V60, 24V60, 48V60, 120V60, 240V60 (1.8W) 6VDC, 12VDC, 24VDC, 48VDC (1.8W)		Plated steel coil housing with M20 x 1.5 conduit entry. Ground terminal on cover. For stainless steel (182FM) coil housing add: (-ST) Maximum pilot pressure 120 psi (8 bar) 1.8W nominal power.																																		
24VDC (D024) 120V60 (A120) 110V50 (E110) 230V50 (E230) 1.8 Watt standard, for lower watt contact factory.	Epoxy molded coils rated for continuous duty, Class H, 180°C.	<table border="1"> <thead> <tr> <th rowspan="2">Stainless steel coil housing with internal Junction Box. Internal and external ground screw.</th> <th colspan="4">Suffix Detail Ordering Code</th> </tr> <tr> <th colspan="2">M 20 Connection</th> <th colspan="2">1/2" Connection</th> </tr> <tr> <td></td> <th>No Diode</th> <th>Diode</th> <th>No Diode</th> <th>Diode</th> </tr> </thead> <tbody> <tr> <td>Standard (vent to atmosphere)</td> <td>XDBS1</td> <td>XDBS5</td> <td>XDBT1</td> <td>XDBT5</td> </tr> <tr> <td>1/8" Adapter (-H2E)</td> <td>XDBS2</td> <td>XDBS6</td> <td>XDBT2</td> <td>XDBT6</td> </tr> <tr> <td>1/4" Adapter (-HE)</td> <td>XDBS3</td> <td>XDBS7</td> <td>XDBT3</td> <td>XDBT7</td> </tr> <tr> <td>Dust Nut (-L14)</td> <td>XDBS4</td> <td>XDBS8</td> <td>XDBT4</td> <td>XDBT8</td> </tr> </tbody> </table>	Stainless steel coil housing with internal Junction Box. Internal and external ground screw.	Suffix Detail Ordering Code				M 20 Connection		1/2" Connection			No Diode	Diode	No Diode	Diode	Standard (vent to atmosphere)	XDBS1	XDBS5	XDBT1	XDBT5	1/8" Adapter (-H2E)	XDBS2	XDBS6	XDBT2	XDBT6	1/4" Adapter (-HE)	XDBS3	XDBS7	XDBT3	XDBT7	Dust Nut (-L14)	XDBS4	XDBS8	XDBT4	XDBT8
Stainless steel coil housing with internal Junction Box. Internal and external ground screw.	Suffix Detail Ordering Code																																			
	M 20 Connection		1/2" Connection																																	
	No Diode	Diode	No Diode	Diode																																
Standard (vent to atmosphere)	XDBS1	XDBS5	XDBT1	XDBT5																																
1/8" Adapter (-H2E)	XDBS2	XDBS6	XDBT2	XDBT6																																
1/4" Adapter (-HE)	XDBS3	XDBS7	XDBT3	XDBT7																																
Dust Nut (-L14)	XDBS4	XDBS8	XDBT4	XDBT8																																
24VDC (4W) (Consult factory for other voltage options)	Continuous duty. Coil & rectifier, including surge suppression, potted within housing.	Thick wall epoxy coil housing with integral junction box. Internal ground terminal. M20 x 1.5 conduit entry: (-XMAA), (-XMFA), Cable gland for 6-12 mm ø cable: (-XMAE), (-XMFE) 1/2 NPT conduit entry with adapter: (-XMAF), (-XMFF) Cable gland for 9-16 mm ø cable: (-XMAG), (-XMFG)																																		
24VDC (10W inrush, 4 W holding) (Consult factory for other voltages)	Continuous duty. Coil & power controller potted with in housing.																																			
24VDC (0.8W) (Consult factory for other voltages)	Continuous duty. Coil and power controller potted within housing.	Requires the use of an approved safety barrier or isolator. Thick wall epoxy coil housing and integral junction box. Internal ground terminal. M20 x 1.5 conduit entry: (-XIFA) Cable gland for 6-12 mm ø cable: (-XIFE) 1/2 NPT conduit entry with adapter: (-XIFF)																																		
24VDC system voltage prior to barrier (1.6 watt max.)	Class F epoxy molded coil (155°C). Continuous duty.	Requires the use of an approved barrier or isolator. Maximum operating system voltage before barrier 28VDC. Maximum pilot pressure 115 psi (8 bar). 3 spade terminals & DIN connector with PG9 cable gland: (-HC) 1/2 NPT conduit entry: (-HCC)																																		

SERIES B316 VALVES

STAINLESS STEEL CONSTRUCTION

Solenoid/Pilot Operated Valves

A low power solenoid controls a built-in pilot which provides the positive force for shifting the valve spool. When used with a spring return the valve will be actuated when the solenoid is energized and will return when the solenoid is de-energized. When used in pairs for 2-position valves, the solenoid need only be energized momentarily in order to shift the valve. The valve will then remain in the shifted position until signalled to return by the opposite solenoid.

INPilot — utilizes the pressure from the inlet of the valve,

through internal passages, to the solenoid-pilot. In this type valve, only one pressure connection, the inlet, is necessary.

EXPilot — requires a separate auxiliary pressure line to the solenoid-pilot. Should be used when valve is controlling vacuum, when pressure will be below the minimum recommended for INPilot operation or when viscosity of controlled medium is such that it will impede the speed of actuation. In any case, the pressure source may be either air or liquid and is independent of the medium which is being controlled by the valve.

Valves For Nonhazardous Locations - 3/2-(Three-Way) Valves

DIMENSIONS: Inch
mm



**Solenoid-Pilot Operated/
Spring Return**

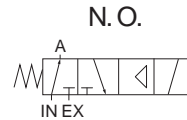
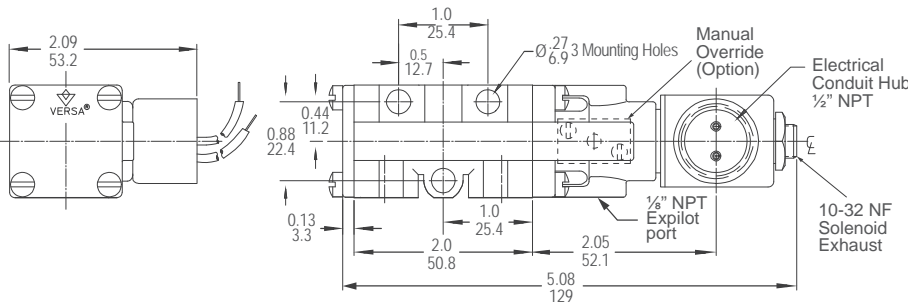

EXPilot type
BSG-3306-316-(*)

INPilot type
BSG-3326-316-(*)

(*) Specify Options (page 11) & coil code (page 9).

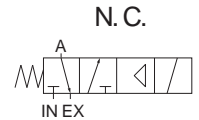

EXPilot type
BSG-3308-316-(*)

INPilot type
BSG-3328-316-(*)

Single Solenoid Valves EXPilot	Controlled (inlet) Pressure																			
	psi	bar	psi	bar	psi	bar	psi	bar	psi	bar	psi	bar	psi	bar	psi	bar	psi	bar	psi	bar
	0-20	0-1.5	40	3	60	4.1	80	5.5	100	6.8	120	8.2	140	10	160	11	175	12	200	14
Auxiliary Min. pilot pressure required	18	1.25	20	1.4	22	1.5	24	1.7	26	1.8	28	2.0	30	2.15	32	2.3	34	2.4	36	2.5

Single Solenoid Valves INPilot	Controlled (inlet) Pressure	
	psi	bar
	18-175	1.25 to 12
Auxiliary pilot pressure required	None	None

DIMENSIONS: Inch
mm



**Solenoid-Pilot Operated/
Solenoid-Pilot Return; (detented)**

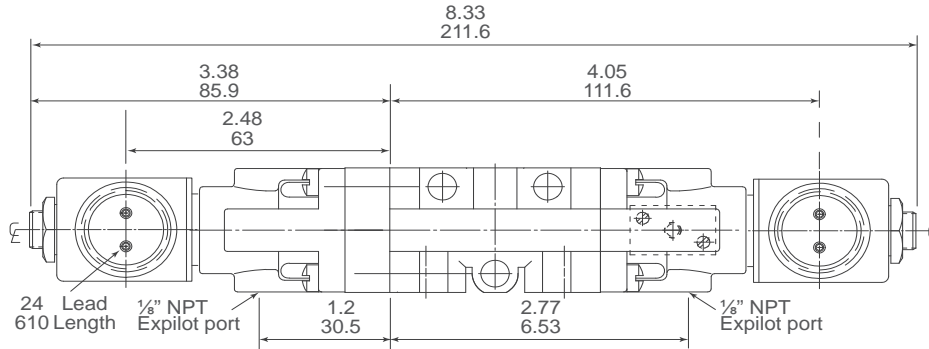

EXPilot type
BGG-3308-316-(*)
(* Specify Options (below) & coil code (page 9).

INPilot type
BGG-3328-316-(*)

Solenoid-pilot operated Solenoid-Pilot return (detented)	Controlled (Inlet) Pressure			
	EXPilot		INPilot	
	psi	bar	psi	bar
	0-200	0-14	15-175	1-12
Auxiliary pilot pressure required	15-175	1-12	none	none

Suffix Options:



-HC DIN STYLE COIL & CONNecTOR: DIN type coil with 3 spade terminals and mini-DIN connector with PG9 cord grip. NEMA 4/IP65.

-3 CONTINUOUS DUTY SOLENOID and/or HIGH AMBIENT OR MEDIA TEMPERATURE: Recommended when coil may be energized for long periods and/or when ambient or media temperature will exceed 120°F (50°C). Standard on all solenoids for hazardous locations.

-HT CLASS H COIL: Recommended for applications above 150°F (65°C) and for DC continuous duty above 120°F (50°C). Not available with DIN style coil and connector.



-ME MANUAL OVERRIDE: Manually pressurized pilot of solenoid pilot actuator. Unguarded type push and hold to operate. Use for set-up or when power to solenoid is absent.

Solenoid Vent Options



Hydraulic Adapter

- H2 1/8"
- H 1/4"



-L14
Dust Proof



-D14
Water Tight

SERIES B316 VALVES

STAINLESS STEEL CONSTRUCTION

Valves For Hazardous Locations - 3/2-(Three-Way) Valves



HAZARDOUS LOCATIONS

Valves with -XX or -LB-XX type solenoids are UL listed and CSA approved.

(d) FLAMEPROOF

Valves with -XN or -LB-XN type solenoids are ATEX certified.

See page 8/9 for additional solenoid details.

DIMENSIONS: Inch
mm

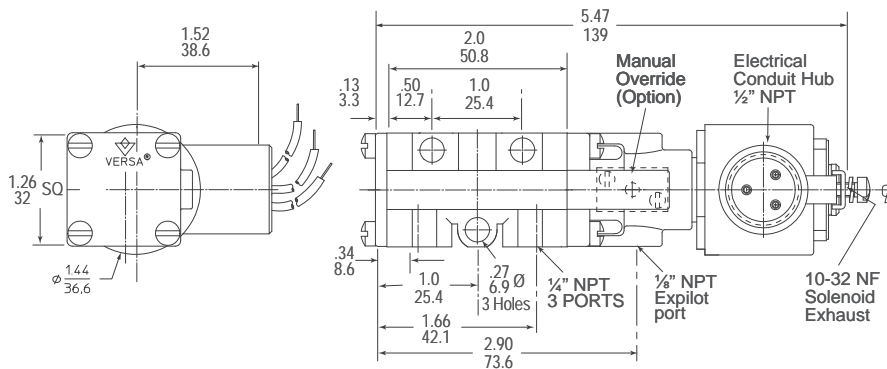

Solenoid-Pilot Operated/ Spring Return

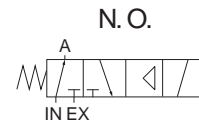

EXPIlot type
BSG-3306-316-†(*)

INPIlot type
BSG-3326-316-†(*)

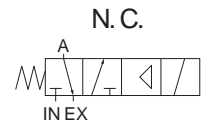

EXPIlot type
BSG-3308-316-†(*)

INPIlot type
BSG-3328-316-†(*)

PRESSURES

Controlled (inlet) pressure & auxiliary pilot pressure (when required) are the same as those shown for the corresponding solenoid valve for non-hazardous locations, Pages 10 & 11.

Solenoid-Pilot Operated/ Solenoid-Pilot Return; (detented)

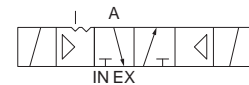
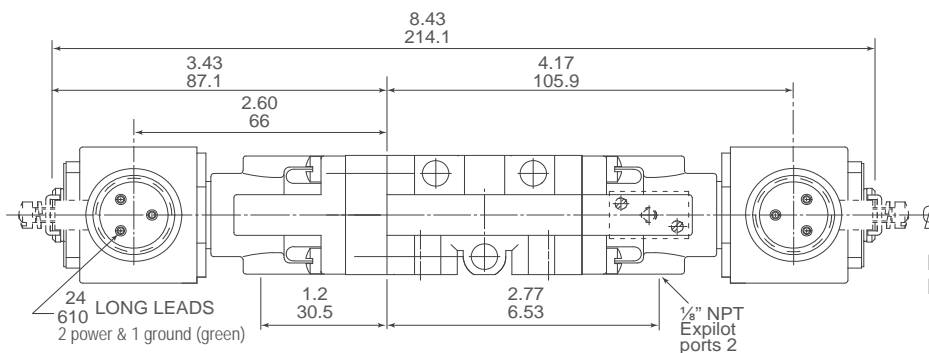

EXPIlot type
BGG-3308-316-†(*)

INPIlot type
BGG-3328-316-†(*)

† Specify solenoid identification detail.

- LB-XN: (d) Flameproof; ATEX certified; low-watt; M20 x 1.5 conduit entry.
- LB-XX: Hazardous Locations; UL listed & CSA approved; low-watt, 1/2 NPT conduit entry.
- XN: (d) Flameproof; ATEX certified; M20 x 1.5 conduit entry.
- XX: Hazardous Locations; UL listed & CSA approved; 1/2 NPT conduit entry.

(*) Specify options (below) & coil code (page 9):

- H2: Threaded pilot exhaust adapter, 1/8 NPT
- ME: Manual override
- PC: Coil potted within housing
- ST: Stainless steel (182 FM) coil housing



(d) FLAMEPROOF
(e) INCREASED SAFETY

Valves with -XDBS or -XDBT type solenoids are ATEX IEC CSA INMETRO certified.

See page 8/9 for additional solenoid details.

DIMENSIONS: Inch
mm

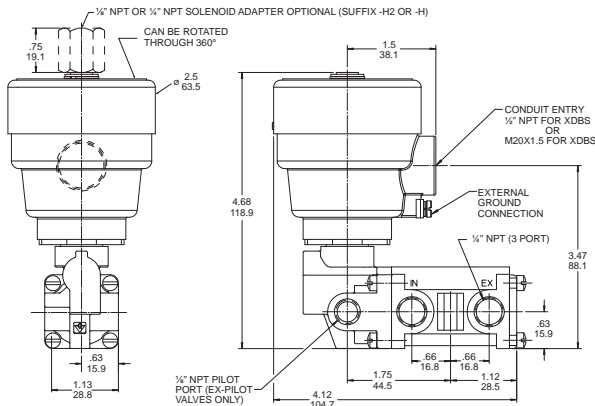

Solenoid-Pilot Operated/Spring Return

N.O.

N.C.

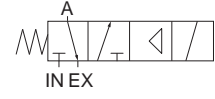

EXPilot type
BSG-3306-316-XDB†-(*)

EXPilot type
BSG-3308-316-XDB†-(*)

INPilot type
BSG-3326-316-XDB†-(*)

INPilot type
BSG-3328-316-XDB†-(*)

**Solenoid-Pilot Operated/
Solenoid-Pilot Return; detented (not shown)**

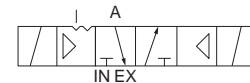

EXPilot type: BGG-3308-316-XDB†-(*)
INPilot type: BGG-3328-316-XDB†-(*)

† Specify solenoid identification detail. S: M20 x 1.5 conduit entry
T: 1/2" NPT conduit entry
(*) Specify options (at left) & coil code (page 9).

PRESSURES

Controlled (inlet) pressure & auxiliary pilot pressure (when required) are the same as those shown for the corresponding solenoid valve for non-hazardous locations, Pages 10 & 11.

Suffix Options:

- H2 Threaded solenoid-pilot exhaust adapter, with 1/8" NPT thread
- H Threaded solenoid-pilot exhaust adapter, with 1/4" NPT thread

(m) ENCAPSULATION
(e) INCREASED SAFETY

Valves with -XMA† or -XMF† type solenoids are ATEX certified.

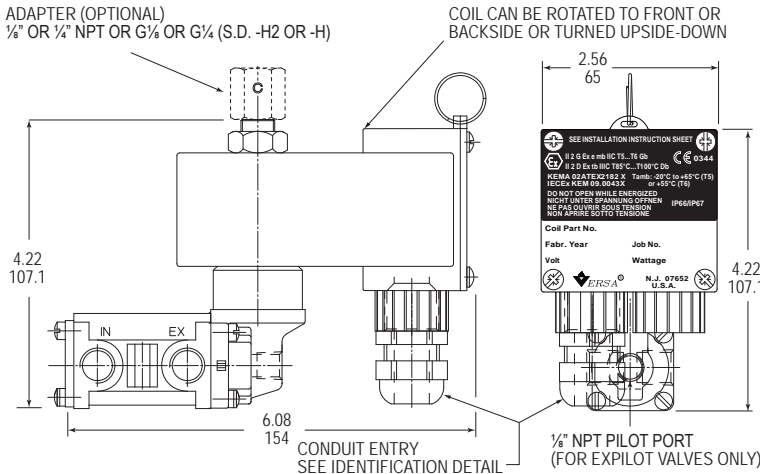
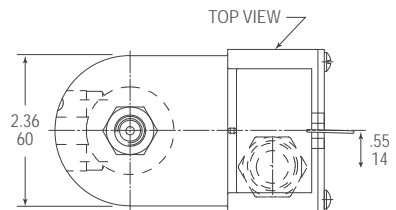

PRESSURES

Controlled (inlet) pressure & auxiliary pilot pressure (when required) are the same as those shown for the corresponding solenoid valve for nonhazardous locations, Pages 10 & 11.

Solenoid-Pilot Operated/ Spring Return

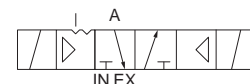
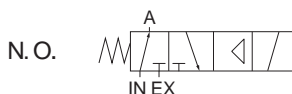

EXPilot type: BSG-3306-316-XMA†-(*)
BSG-3306-316-XMF†-(*)
INPilot type: BSG-3326-316-XMA†-(*)
BSG-3326-316-XMF†-(*)

BSG-3308-316-XMA†-(*)
BSG-3308-316-XMF†-(*)
BSG-3328-316-XMA†-(*)
BSG-3328-316-XMF†-(*)

BGG-3308-316-XMA†-(*)
BGG-3308-316-XMF†-(*)
BGG-3328-316-XMA†-(*)
BGG-3328-316-XMF†-(*)

†Specify solenoid identification detail.

A: M20 x 1.5 conduit entry;
E: Cable gland for 6-12 mm ø cable;

F: 1/2" NPT conduit entry;
G: Cable gland for 9-16 mm ø cable

(*) Specify coil code (page 9).

SERIES B316 VALVES

STAINLESS STEEL CONSTRUCTION

Valves For Hazardous Locations - 3/2-(Three-Way) Valves



HAZARDOUS LOCATIONS

Valves with -HC-XISC or HCC-XISC are CSA and Factory Mutual approved.

(ia) INTRINSIC SAFE

Valves with -HC-XISX6 or HCC-XISX6 are ATEX certified.

DIMENSIONS: Inch
mm

See page 8/9 for additional solenoid details.

PRESSURES

Controlled (inlet) pressure & auxiliary pilot pressure (when required) are the same as those shown for the corresponding solenoid valve for nonhazardous locations, Pages 10 & 11, EXCEPT maximum auxiliary pilot pressure for EXPilot valves & maximum controlled (inlet) pressure for INPilot valves is 115 psi (8 bar).

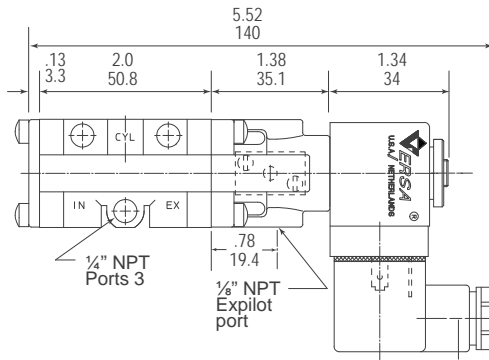

Solenoid-Pilot Operated/ Spring Return

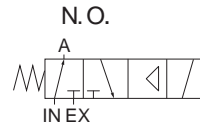

EXPilot
BSG-3306-316-HC-XIS†-D024
BSG-3306-316-HCC-XIS†-D024

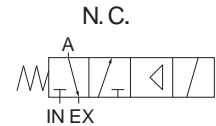

EXPilot
BSG-3308-316-HC-XIS†-D024
BSG-3308-316-HCC-XIS†-D024

INPilot
BSG-3326-316-HC-XIS†-D024
BSG-3326-316-HCC-XIS†-D024

INPilot
BSG-3328-316-HC-XIS†-D024
BSG-3328-316-HCC-XIS†-D024

Solenoid-Pilot Operated/ Solenoid-Pilot Return; detented



EXPilot
BGG-3308-316-HC-XIS†-D024
BGG-3308-316-HCC-XIS†-D024

INPilot
BGG-3328-316-HC-XIS†-D024
BGG-3328-316-HCC-XIS†-D024

† Specify solenoid identification detail. C or X6 (See page 8/9 for solenoid details).

(ib) INTRINSIC SAFE

Valves with -XIF† type solenoids are ATEX approved.

See page 8/9 for additional solenoid details.

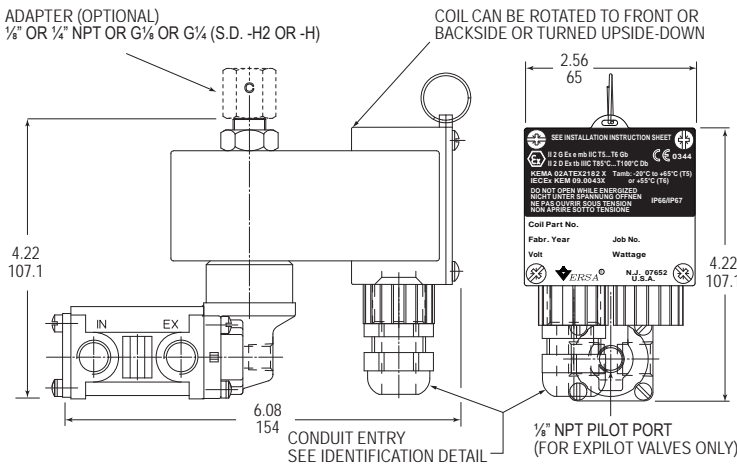

Solenoid-Pilot Operated/ Spring Return

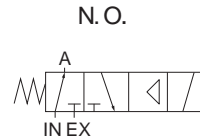

EXPilot
BSG-3306-316-XIF†-(*).

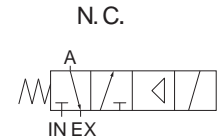

EXPilot
BSG-3308-316-XIF†-(*).

INPilot
BSG-3326-316-XIF†-(*).

INPilot
BSG-3328-316-XIF†-(*).

Solenoid-Pilot Operated/ Solenoid-Pilot Return; detented (not shown)



EXPilot BGG-3308-316-XIF†-(*)
INPilot BGG-3328-316-XIF†-(*)

PRESSURES

Controlled (inlet) pressure & auxiliary pilot pressure (when required) are the same as those shown for the corresponding solenoid valve for nonhazardous locations, Pages 10 & 11.

†Specify solenoid identification detail. A: M20 x 1.5 conduit entry;
E: Cable gland for 6-12 mm ø cable;
F: 1/2" NPT conduit entry;

(*). Specify coil code (page 9).

General Description

Designed for use in emergency shut down systems, Manual Shut-Off valves are available in two types.

The Two-Way (2/2) valve is designated as a Block & Bleed valve. When the panel knob is pulled out, supply pressure is dumped to atmosphere.

The Three-Way (3/2) valve is designated as a Charge & Bleed valve. In the normal operating mode of this valve

the inlet port is connected to the outlet port and the exhaust port is blocked. When the panel knob is pulled out, supply pressure to the outlet port is blocked and the downstream pressure is dumped to atmosphere.

Any backpressure to the outlet port of either valve while functioning in the normal mode, will cause the valve to shift as if the panel knob were pulled out.

OPERATING PRESSURE AND WEIGHT	Weight	SYSTEM PRESSURE	ALLOWABLE BACKPRESSURE at Outlet Port (Two-Way) or Exhaust Port (Three-Way)
Two-Way (2/2) Block & Bleed MSO2-3-316	0.77 lbs. (.35kg)	0-150 psi (0-10 bar)	0
Three-Way (3/2) Charge & Bleed MSO3-3-316	1.0 lbs. (.45 kg)	0-150 psi (0-10 bar)	0

Materials

- Valve body and caps: 316 stainless steel (meets NACE Standard MR-01-75)
- Valve Seals: FKM (Fluorocarbon) O rings
- Screws: stainless steel
- Lid Knob: synthetic resin.

Porting Size and Flow

Inlet, outlet & exhaust ports: 1/4" NPT
Internal orifice: 3/8" (9.5 mm) ø

Installation

Valves have no limitations on mounting orientation. Valves can be panel mounted. Panel hole required: 1" (25.4 mm) ø

TWO-WAY (2/2) BLOCK & BLEED

Product Number

MSO2-3-316
MSO2-3-316-125B

Button Color

Red
Black

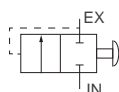
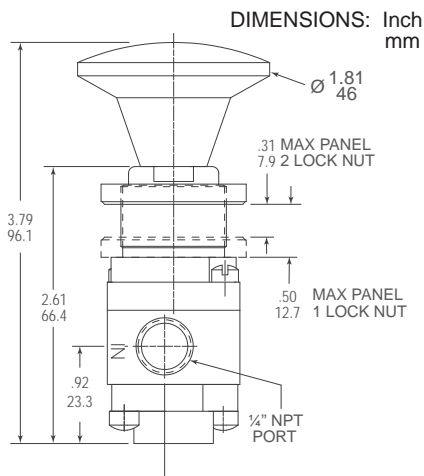

THREE-WAY (3/2) CHARGE & BLEED

Product Number

MSO3-3-316
MSO3-3-316-125R

Button Color

Black
Red

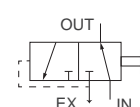
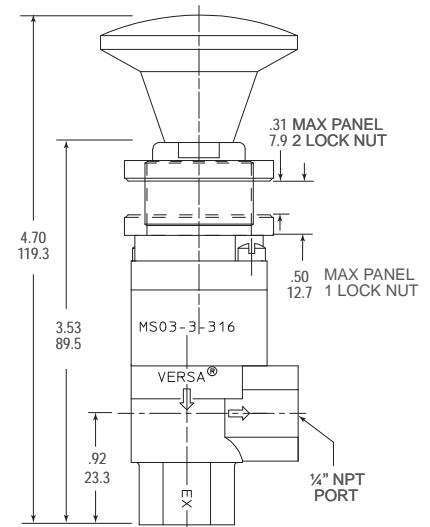

Main Supply Reset Valves

General Description

Main Supply Reset Valves are Manual/Pilot operated, Spring Return, Three-Way (3/2), normally closed valves that are generally used to control and monitor the air pressure supply to an instrument control system. Monitoring is accomplished through the use of a monitor pilot, which is an integral part of the valve and which reacts to pressure signals from sensors within the system in order to shut down that specific portion of the system, should a malfunction occur.

The action of the valve for shut down and the method by which the control system pressure is restored differentiates the various Main Supply Reset valves available.

Knob Actuator —

The manual portion of the valve provides a lid knob which can be pulled out to actuate the valve, in order to start up or reset the control system pressure. A latch can be provided such that, once actuated, the valve can be manually latched in the actuated position. Unlatching might be accomplished by pulling on the knob or by applying pressure to the pilot.

An optional visual indicator, which is an integral part of the knob, can also be provided in order to indicate when pressure in the pilot chamber is actuating the valve.

All knob actuators are equipped for panel mounting utilizing a panel mounting nut which is included.

Air Pilot Actuator —

The air pilot portion of the valve is a small cylinder which is an integral part of the valve. The types available are:

Air Pilot - when pressurized will actuate the valve, and will unlatch the knob actuator if the latching feature is included.

Air Latch Pilot - when pressurized will not actuate the valve until knob is pulled out. Pressure in the pilot chamber can then hold the valve in the actuated position, and will unlatch the knob actuator if the latching feature is included.

Construction

Versa B900 Valves are spool poppet valves. Standard size O ring seals, placed in accordance with Versa's Anti-Extrusion principle provides long trouble free service with little and easy maintenance.

Materials

- Valve body and actuating caps: 316 stainless steel
- All internal wetted metal parts: 316 stainless steel or NACE approved materials
- Valve Seals: FKM (Fluorocarbon) O ring seals
- Screws: stainless steel

Porting

- Valve ports are 1/4 NPT; Pilot ports are 1/8 NPT
- Flow area/Cv; consult factory

Pressure and Media

- 0 to 200 psig (14 bar); Air or Hydrocarbon gases or other gases compatible with materials used.
- Pressures for Pilot: see pages pertaining to specific valve.

Temperature Range

Medium/Ambient temperature: -10°F (-23°C) to 200°F (95°C)

Installation, Filtration & Lubrication

Valves have no limitations on mounting orientation. 40-50 micron filtration recommended. General purpose lubricating oil ISO, ASTM viscosity grade 32 recommended.

MAIN SUPPLY RESET VALVES SELECTOR

Non-latching	Knob Actuator			Pilot Actuator		Valve Suffix
	Manual Pin Latch	Non-indicating	Indicating	Air Pilot	Air Latch Pilot	
X		X		X		-159E (page 17)
X		X			X	-301ES (page 18)
X			X		X	900N (page 18)
	X	X		X		900A (page 17)
	X	X			X	900 (page 18)
	X		X	X		900P (page 17)
	X		X		X	900W (page 18)
	X Manually resets valve plus, a built-in pilot (separate from Air Latch Pilot) enables valve to be reset from a remote location utilizing a pilot pressure signal.	X			X	900PR (page 19)
	X	X			X Functions same as Air Latch Pilot, but pilot signal is controlled by built-in solenoid.	900G (page 19)
X			X		X	900NF (page 19)

Functions same as Air Latch Pilot plus, will trip if outlet port (which is connected to indicator valve loop) loses pressure, as in the case of a leak

Main Supply Reset Valves - 3/2 (Three Way) Normally Closed Type: Air Pilot*

These valves can be actuated (open to flow) by a pilot signal or manually by pulling the knob when there is no pilot signal. When the pilot signal is removed or drops below 7 psi (0.5 bar), or the knob is released when there is no pilot pressure, the valve will spring return to close the flow.

Valves provided with the manual pin latch feature can be latched in the actuated position (open to flow) when there is no pilot pressure, by pushing the manual latch pin and holding it in while the knob is pulled out and released. To release the

manual pin latch, pull the knob or apply a pilot signal.

Valves provided with a pressure indicator will appear **red** (black character "R" is also visible) when there is no pressure in the pilot chamber or the pilot pressure drops below 7 psi (0.5 bar), at which point the spring will return the valve to close the flow. The pressure indicator will appear **green** (black character "G" is also visible) when there is pilot pressure present in the pilot chamber.

DIMENSIONS: Inch
mm

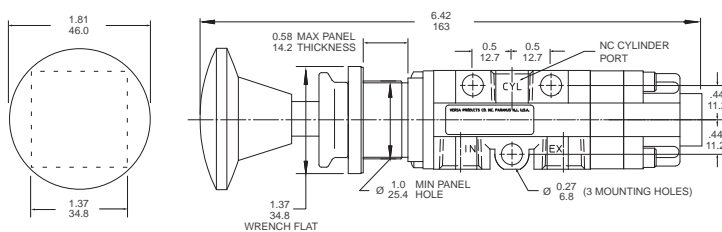

Knob: Non-Latching, Non-Indicating

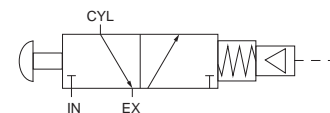

BIA-3309-316-159E

* **Pilot signal required:** 25-200 psi (1.7-14 bar)
When available pilot signal will not be less than 40 psi, Suffix Option -S is recommended.

Maximum allowable exhaust backpressure: 5 psi (0.3 bar)

Knob: Latching, Non-Indicating

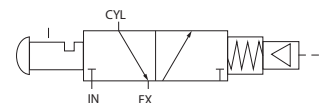

BAA-3309-900A

* **Pilot signal required:** 25-200 psi (1.7-14 bar)
When available pilot signal will not be less than 40 psi, Suffix Option -S is recommended.

Maximum allowable exhaust backpressure: 5 psi (0.3 bar)

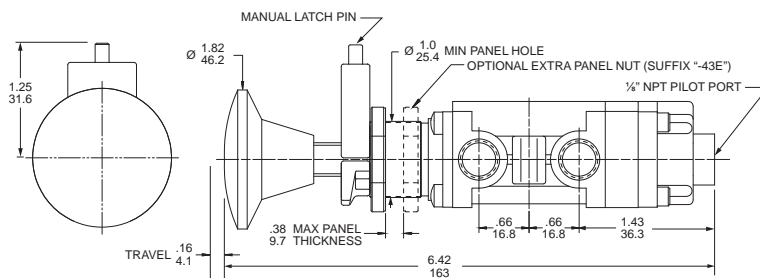

Knob: Latching, Indicating

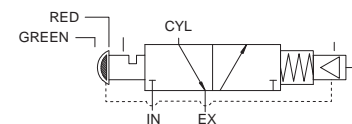

BAA-3309-900P

* **Pilot signal required:** 25-200 psi (1.7-14 bar)
When available pilot signal will not be less than 40 psi, Suffix Option -S is recommended.

Maximum allowable exhaust backpressure: 5 psi (0.3 bar)

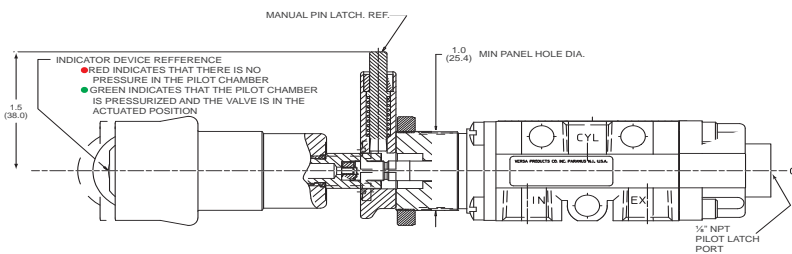

Series B900 VALVES

STAINLESS STEEL CONSTRUCTION

Main Supply Reset Valves - 3/2 (Three-Way) Normally Closed Type: Air Latch Pilot*

Pressure applied to the pilot latch port will not cause the pilot chamber to be pressurized until the knob is manually pulled out. Pilot pressure will then hold the valve open to flow against the spring. If the pilot pressure drops below 7 psi (0.5 bar) the spring will shift the valve to close the flow, and even if the pilot signal is restored, the valve will remain closed until the knob is manually pulled out.

Valves provided with the manual latch feature can be latched in the actuated position (open to flow) when there is no pilot pressure, by pushing the manual latchpin and holding it in while the

knob is pulled out and released. To release the manual latch, pull the knob or apply a pilot signal.

Valves provided with a pressure indicator will appear **red** (black character "R" is also visible) when the pilot chamber is not pressurized. The pilot chamber cannot be pressurized until the knob is pulled out at which point the indicator will appear **green** (black character "G" is also visible). If the pilot signal is then lost the spring will return the valve to close the flow and the indicator will appear **red** (R).

DIMENSIONS: Inch
mm

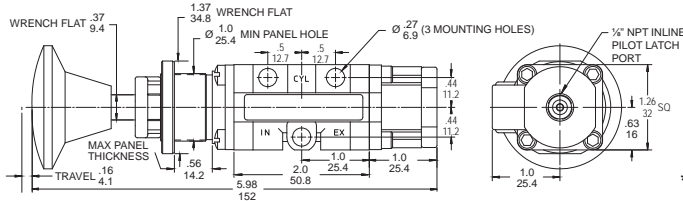

Knob: Non-Latching, Non-Indicating

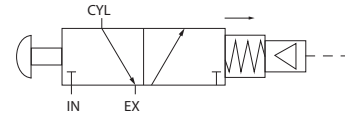

BIA-3309-316-301ES

* Pilot signal required: 25-200 psi (1.7-14 bar)
When available pilot signal will not be less than 40 psi, Suffix Option -S is recommended.

Maximum allowable exhaust backpressure: 5 psi (0.3 bar)

Knob: Non-Latching, Indicating

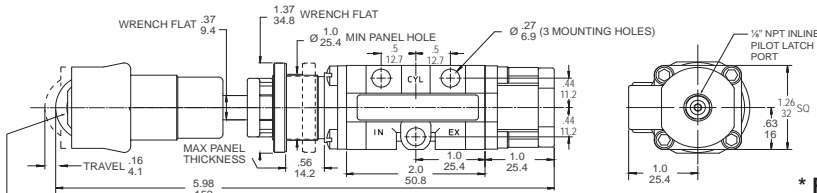

INDICATOR DEVICE REFERENCE
 • RED INDICATES THAT THERE IS NO PRESSURE IN THE PILOT LATCH CHAMBER.
 • GREEN INDICATES THAT THE PILOT LATCH CHAMBER IS PRESSURIZED AND THE VALVE IS IN THE ACTIVATED POSITION

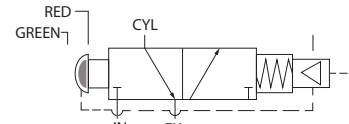

BAA-3309-900N

* Pilot signal required: 25-200 psi (1.7-14 bar)
When available pilot signal will not be less than 40 psi, Suffix Option -S is recommended.

Maximum allowable exhaust backpressure: 5 psi (0.3 bar)

Knob: Latching, Non-Indicating

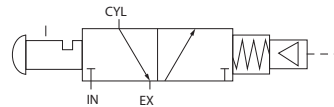
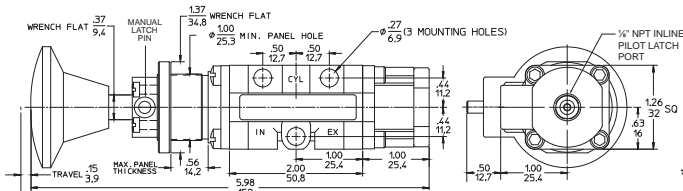

BAA-3309-900

* Pilot signal required: 25-200 psi (1.7-14 bar)
When available pilot signal will not be less than 40 psi, Suffix Option -S is recommended.

Maximum allowable exhaust backpressure: 5 psi (0.3 bar)

Knob: Latching, Indicating

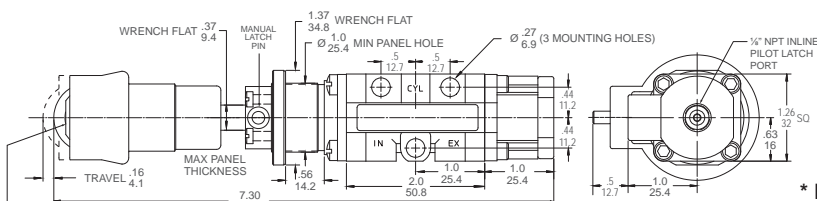

INDICATOR DEVICE REFERENCE
 • RED INDICATES THAT THERE IS NO PRESSURE IN THE PILOT LATCH CHAMBER.
 • GREEN INDICATES THAT THE PILOT LATCH CHAMBER IS PRESSURIZED AND THE VALVE IS IN THE ACTIVATED POSITION

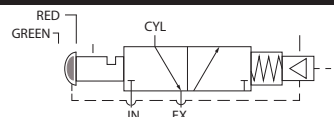

BAA-3309-900W

* Pilot signal required: 25-200 psi (1.7-14 bar)
When available pilot signal will not be less than 40 psi, Suffix Option -S is recommended.

Maximum allowable exhaust backpressure: 5 psi (0.3 bar)

Main Supply Reset Valves - 3/2 (Three-Way) Normally Closed Type: Specialized Application

DIMENSIONS: Inch
mm

Description Function is the same as Air Latch Pilot types on page 18 except that internal connection from CYL port to pilot provides the valve with a means to trip the valve closed to flow should a leak or other loss of pressure occur in the indicator loop line that connects "Indicator valves" to the pilot port. This feature eliminates need for separate connection from CYL port to "Indicator valves".

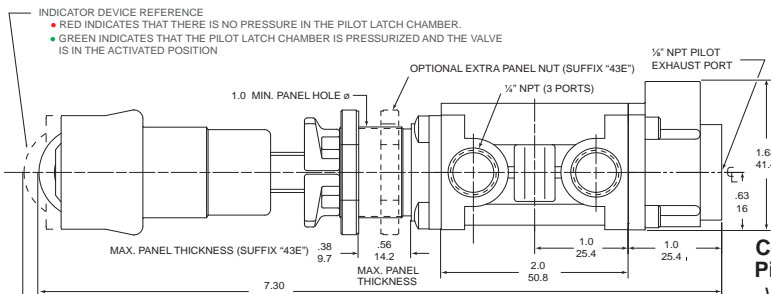

Knob: Non-Latching, Indicating

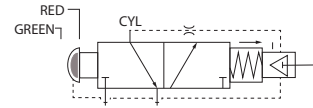

BAA-3309-900NF

Controlled Pressure: 0-75 psi (10-5.1 bar)
Pilot pressure required: 25-75 psi (1.7-5.1 bar) to maintain air latch
 When available pilot signal will not be less than 40 psi, Suffix Option -S is recommended.

Maximum allowable exhaust backpressure: 5 psi (0.3 bar)

Description Function is the same as Air Latch Pilot types on page 18, but valve is additionally equipped with a Remote Pilot so that the valve can be reset with a remote pilot signal as well as manually. However, the manual pin latch is not activated by the remote pilot signal, so the valve will remain reset only as long as the remote pilot signal remains intact. Generally, this feature is useful where the Main Supply Reset valve is somewhat inaccessible and allows the operator to reset the valve from a separate location, until the operator is able to get to the station and activate the pin latch.

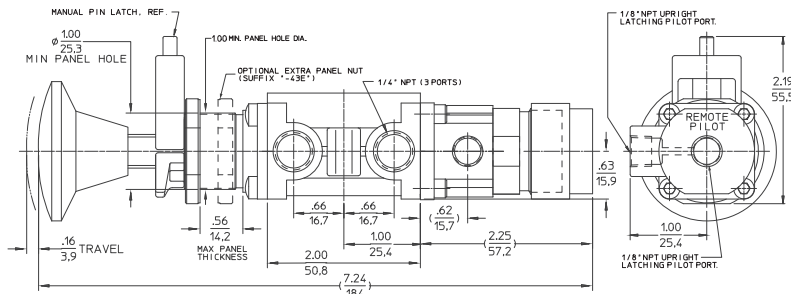

Knob: Latching, Non-Indicating

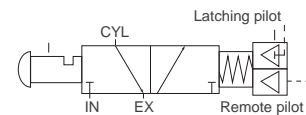

BAA-3309-900PR

Controlled Pressure: 0-200 psi (10-14 bar)
*** Pilot pressure required:** 50-200 psi (3.4-14 bar) to unlatch manual pin and to maintain air latch or actuate remotely

Maximum allowable exhaust backpressure: 5 psi (0.3 bar)

Description Function is the same as Air Latch Pilot types on page 18, except Air Latch Pilot is solenoid controlled. Electrical signal causes pressure to be admitted to the pilot chamber from valve inlet through an internal passage to pilot, but Air Latch Pilot is not activated until knob is manually pulled out. The manual pin latch can be activated once the solenoid is de-energized.

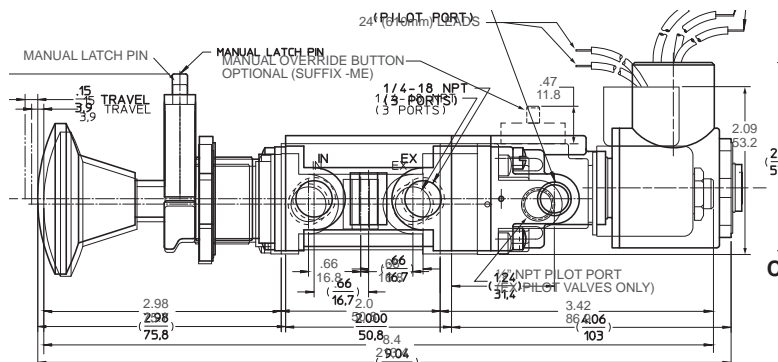

Knob: Latching, Non-Indicating

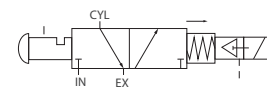

BAA-3309-900G-(*)

*Specify coil code Page 9

Controlled Pressure: 25-120 psi (1.7-8.2 bar)
 25 psi (1.7 bar) minimum to unlatch manual pin or to maintain air latch
 When available inlet pressure will not be less than 40 psi, Suffix Option -S is recommended.
Maximum allowable exhaust backpressure: 5 psi (0.3 bar)

Series B900 & B550 VALVES

STAINLESS STEEL

HARDCOATED ALUMINUM

CONSTRUCTION

Indicating Relay – Pilot Monitoring Valves

Indicating Relay valves are used to monitor the pilot actuators of the Main Supply Relay valves listed on pages 16-19. The Indicating Relays have two functions. First, to indicate visually on a panel that a circuit malfunction has occurred and secondly, to quickly cause operating pressure to exhaust from the system through the Main Supply Relay valve, allowing a valve operator or pneumatic system to shut-down. When placed in

series with other Indicating Relays, only the relay indicator of the relay controlling the circuit for which a malfunction is sensed will show **red (R)**.

Three types of Indicating Relays are available:
 First Out Indicator-Transmitting type (page 20)
 First Out Indicator-Receiving type (page 21)
 First Out Indicator-Bypass type (page 22)

FIRST OUT INDICATOR/INDICATING RELAY-TRANSMITTING TYPE

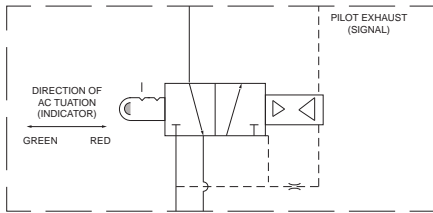

Dimensions are approximate. Consult factory for actual dimensions of specific valves.

BAA-3308-900R	Construction: Body, Internals, Caps	BAA-3308-550R
316 stainless steel (NACE MR-01-75)		Hardcoated Aluminum (MIL-A-8625E, Type III, Class1)
Stainless steel	Fasteners-	Stainless steel
FKM (fluorocarbon) O rings	Seals-	FKM (fluorocarbon) O rings
25-130 psi (1.7-8.8 bar)	Pressures: Working (Controlled) pressure range-	15-120 psi (1- 8.2 bar)
5 psi (0.3 bar)	Maximum allowable exhaust backpressure-	5 psi (0.3 bar)
See Charts A & B below	Pilot trip/reset-	See Charts A & B below
Consult Factory	Flow:	Consult Factory
Air - 40 to 50 micron filtration recommended	Media:	Air - 40 to 50 micron filtration recommended
1/4" NPT 1/8" NPT	Porting: Valve Ports- Pilot Ports-	1/4" NPT 1/8" NPT
Panel Mount (1"Ø hole)	Mounting & Installation:	Panel Mount (1"Ø hole)
Red (black character "R") Green (black character "G")	Indicator colors: Trip mode (depressurized)- Working mode (pressurized)-	Red (black character "R") Green (black character "G")
(Consult factory for other color availability)		

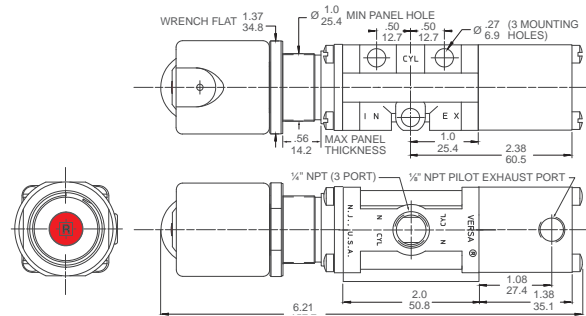

Transmitting Relay Circuit (system in mode A - working range)

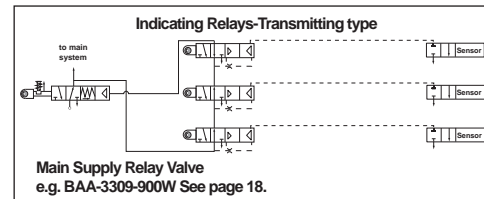

Operation Mode A

Flow path is open between the Relay inlet and "CYL" port whenever both the Relay inlet and pilot pressure are within the working pressure range in Chart A. In this condition the Relay indicator is **green (G)**. If the Relay inlet pressure is lost while in this mode, the Relay flow position and indicator color will remain unchanged.

Pressure Chart "A" (working range): Indicating Relay-Transmitting type																
Indicating Relay Valve Inlet Pressure	BAA-3308-900R	PSIG	—	—	25	30	40	50	60	70	80	90	100	110	120	130
	BAA-3308-550R	PSIG	15	20	—	30	40	50	60	70	80	90	100	110	120	—
Minimum Reset- Pilot Pressure	BAA-3308-900R	PSIG	—	—	25	30	37	45	54	63	72	77	85	92	100	110
	BAA-3308-550R	PSIG	15	18	—	24	29	35	40	46	51	57	61	65	74	—
		BAR	1.0	1.4	—	2.0	2.7	3.4	4.1	4.8	5.4	6.1	6.8	7.5	8.2	—
		BAR	1.0	1.2	—	1.6	2.0	2.4	2.7	3.1	3.5	3.9	4.2	4.4	5.0	—

Operation Mode B

Flow path is open between the Relay "CYL" port and exhaust port whenever the Relay pilot chamber backpressure does not exceed the specifications in Chart B. In this condition the Relay indicator is **red (R)**. The relay will automatically reset to operation mode A when both the Relay inlet and pilot pressure return to the working range, as indicated in Chart A

Pressure Chart "B" (shut-down range): Indicating Relay-Transmitting type																
Indicating Relay Valve Inlet Pressure	BAA-3308-900R	PSIG	—	—	25	30	40	50	60	70	80	90	100	110	120	130
	BAA-3308-550R	PSIG	15	20	—	30	40	50	60	70	80	90	100	110	120	—
Minimum Trip- Pilot Pressure	BAA-3308-900R	PSIG	—	—	10	16	22	28	35	42	50	57	63	70	77	85
	BAA-3308-550R	PSIG	1	4	—	10	15	21	26	32	37	44	47	53	59	—
		BAR	0.07	0.3	—	0.7	1.0	1.4	1.8	2.2	2.5	3.0	3.2	3.6	4.0	—

FIRST OUT INDICATOR/INDICATING RELAY-RECEIVING TYPE



Dimensions are approximate.
Consult factory for actual dimensions of specific valves.

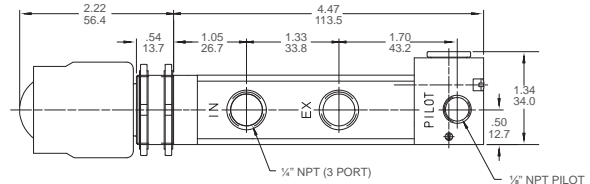
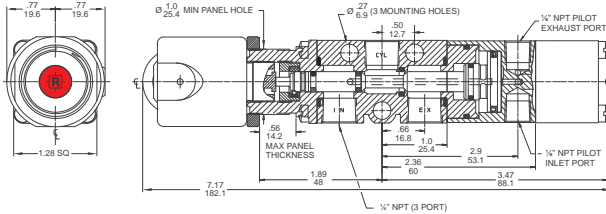
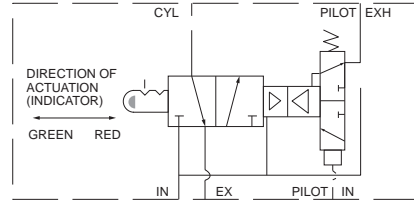

BAA-3308-900RA		BAA-3308-550RA																								
316 Stainless Steel (NACE MR-01-75)	Construction: Body, Internals, Caps Fasteners Seals	Hardcoated Aluminum (MIL-A-8625E, Type III, Class1)	Pressures: Working (Controlled) Pressure Range Maximum allowable Exhaust backpressure																							
Stainless steel		Stainless steel																								
FKM (ASTM D-1418) (ISO-1629)– (fluorocarbon) O rings		FKM (fluorocarbon) O rings																								
25-130 psi (1.7-8.8 bar)	Pilot trip/reset	15-120 psi (1-8.2 bar)	psi (bar)																							
5 psi (0.3 bar)		5 psi (0.3 bar)																								
25-130 psi (1.7-8.8 bar)		<table border="1" style="font-size: small;"> <thead> <tr> <th>Inlet Pressure</th> <th>Min. Reset Pilot Pressure</th> <th>Max. Trip Pilot Pressure</th> </tr> </thead> <tbody> <tr><td>15 (1.0)</td><td>9 (0.6)</td><td>3 (0.2)</td></tr> <tr><td>30 (2.0)</td><td>14 (1.0)</td><td>6 (0.4)</td></tr> <tr><td>50 (3.4)</td><td>23 (1.6)</td><td>12 (0.8)</td></tr> <tr><td>70 (4.8)</td><td>31 (2.1)</td><td>20 (1.4)</td></tr> <tr><td>90 (6.1)</td><td>38 (2.6)</td><td>27 (1.8)</td></tr> <tr><td>110 (7.5)</td><td>46 (3.1)</td><td>33 (2.2)</td></tr> <tr><td>120 (8.2)</td><td>50 (3.4)</td><td>37 (2.5)</td></tr> </tbody> </table>	Inlet Pressure	Min. Reset Pilot Pressure	Max. Trip Pilot Pressure	15 (1.0)	9 (0.6)	3 (0.2)	30 (2.0)	14 (1.0)	6 (0.4)	50 (3.4)	23 (1.6)	12 (0.8)	70 (4.8)	31 (2.1)	20 (1.4)	90 (6.1)	38 (2.6)	27 (1.8)	110 (7.5)	46 (3.1)	33 (2.2)	120 (8.2)	50 (3.4)	37 (2.5)
Inlet Pressure	Min. Reset Pilot Pressure	Max. Trip Pilot Pressure																								
15 (1.0)	9 (0.6)	3 (0.2)																								
30 (2.0)	14 (1.0)	6 (0.4)																								
50 (3.4)	23 (1.6)	12 (0.8)																								
70 (4.8)	31 (2.1)	20 (1.4)																								
90 (6.1)	38 (2.6)	27 (1.8)																								
110 (7.5)	46 (3.1)	33 (2.2)																								
120 (8.2)	50 (3.4)	37 (2.5)																								
Consult Factory	Flow: Controlled flow	Consult Factory																								
Air	Media: (40 to 50 micron filtration recommended)	Air																								
1/4" NPT 1/8" NPT	Porting: Valve Ports Pilot Ports	1/4" NPT 1/8" NPT																								
Panel mount (1"Ø hole)	Mounting & Installation:	Panel Mount (1"Ø hole)																								
● Red (black character "R") ● Green (black character "G")	Indicator Colors: Trip mode (depressurized) Working mode (pressurized) (Consult factory for other color availability)	● Red (black character "R") ● Green (black character "G")																								

Operation Mode A

Flow path is open between the Relay inlet and "CYL" port whenever the pilot pressure from the process monitor and the Relay inlet pressure is in the working pressure range. In this condition the Relay indicator is green (G). If the loss of inlet pressure occurs while in this mode, the relay flow position and indicator color will remain unchanged.

Operation Mode B

Upon loss of the pilot signal or decrease to the minimum trip pressure, the Relay will shift to block the inlet and to open the exhaust to the "CYL" port. In this condition the indicator shows red (R). The Relay will not reset to green (G) until both sufficient pilot and inlet pressure are restored into the Relay.

Receiving Relay Circuit (system in mode A - working range)

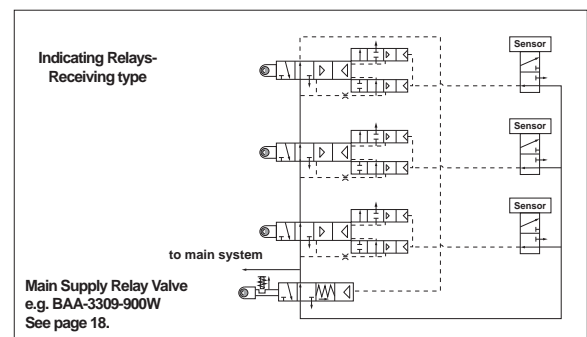

Series B900 & B550 VALVES

STAINLESS STEEL

HARDCOATED ALUMINUM

CONSTRUCTION

Indicating Relay – Pilot Monitoring Valves

FIRST OUT INDICATOR/INDICATING RELAY-RECEIVING TYPE WITH INTEGRAL BYPASS

The First Out Indicator with an integral bypass combines the functions of two valves into one. Its primary function is that of the First Out Indicator/Indicating Relay-Receiving type (BAA-3308-550RA or BAA-3308-900RA) as shown on page 21. Additionally, an integral bypass valve enables specific circuits to be bypassed in the event of a malfunction, without shutdown

of the entire system. The additional piping, fittings and labor usually required to accomplish this feature are thus eliminated through the use of the Bypass type Indicating Relay valve. The bypass is accomplished by manually rotating (90°) a detented lever as part of the valve.

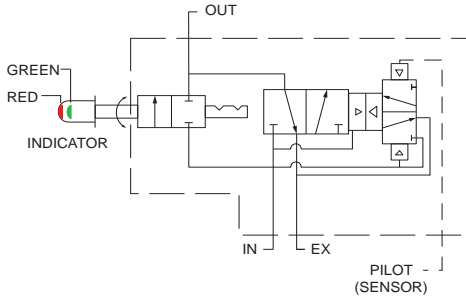

Dimensions are approximate. Consult factory for actual dimensions of specific valves.

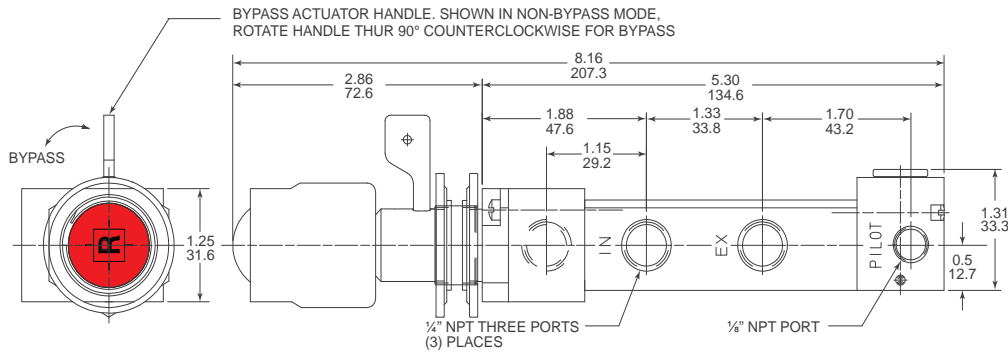

BAA-3308-550RAB

Construction: Body, Internals, Caps	Hardcoated Aluminum (MIL-A-8625E, Type III, Class 1)																								
Seals	FKM (fluorocarbon)																								
Fasteners & Bypass lever	stainless steel																								
Pressures:																									
Working (Controlled) pressure range	15-120 psi (1-8.2 bar)																								
Maximum allowable exhaust backpressure	5 psi (0.3 bar)																								
Pilot trip/reset	<table border="1"> <thead> <tr> <th>Inlet Pressure</th> <th>Min. Reset Pilot Pressure</th> <th>Max. Trip Pilot Pressure</th> </tr> </thead> <tbody> <tr> <td>15 (1.0)</td> <td>9 (0.6)</td> <td>3 (0.2)</td> </tr> <tr> <td>30 (2.0)</td> <td>14 (1.0)</td> <td>6 (0.4)</td> </tr> <tr> <td>50 (3.4)</td> <td>23 (1.6)</td> <td>12 (0.8)</td> </tr> <tr> <td>70 (4.8)</td> <td>31 (2.1)</td> <td>20 (1.4)</td> </tr> <tr> <td>90 (6.1)</td> <td>38 (2.6)</td> <td>27 (1.8)</td> </tr> <tr> <td>110 (7.5)</td> <td>46 (3.1)</td> <td>33 (2.2)</td> </tr> <tr> <td>120 (8.2)</td> <td>50 (3.4)</td> <td>37 (2.5)</td> </tr> </tbody> </table>	Inlet Pressure	Min. Reset Pilot Pressure	Max. Trip Pilot Pressure	15 (1.0)	9 (0.6)	3 (0.2)	30 (2.0)	14 (1.0)	6 (0.4)	50 (3.4)	23 (1.6)	12 (0.8)	70 (4.8)	31 (2.1)	20 (1.4)	90 (6.1)	38 (2.6)	27 (1.8)	110 (7.5)	46 (3.1)	33 (2.2)	120 (8.2)	50 (3.4)	37 (2.5)
Inlet Pressure	Min. Reset Pilot Pressure	Max. Trip Pilot Pressure																							
15 (1.0)	9 (0.6)	3 (0.2)																							
30 (2.0)	14 (1.0)	6 (0.4)																							
50 (3.4)	23 (1.6)	12 (0.8)																							
70 (4.8)	31 (2.1)	20 (1.4)																							
90 (6.1)	38 (2.6)	27 (1.8)																							
110 (7.5)	46 (3.1)	33 (2.2)																							
120 (8.2)	50 (3.4)	37 (2.5)																							
Flow:	Consult factory																								
Media:	Air 40 to 50 micron filtration recommended																								
Porting: Valve ports Pilot ports	1/4" NPT 1/8" NPT																								
Mounting & Installation:	Panel mount (1" ø hole)																								
Indicator Colors: Trip mode (depressurized) Working mode (pressurized)	Red (black character "R") Green (black character "G")																								

Consult factory for other color availability

Repair Kits & Information

VERSA Valves are designed and built to provide millions of trouble free cycles. However, in the event that a valve should require repair, most likely due to wear or some kind of abuse, in most cases the valve can be restored to “new” condition by the replacement of the valve seals. Kits containing the necessary items are available and are listed below, for specific valve types.

CAUTION: Before attempting to repair any VERSA Valve, always be certain that all pressure in the system including the valve to be repaired, has been turned off and the system and valve has been depressurized before proceeding with the repair. Serious injury or death may occur if this procedure is neglected.

SERIES B316 VALVES	Valve Product Number	Repair Kit Number
ALL		*B-3308-316
Manual-	BSI or BIA	
Cam-	BSC	
Pilot-	BSP or BPP	*Additional nonhazardous solenoid parts not included in kit:
Solenoid	BSG or BGG	
(nonhazardous & hazardous location) VALVES		P-1005-08 Solenoid Plunger P-1005-02-(Coil Code) Coil

For valves with Suffix Option -EP add -EP to product number listed above.

MAIN SUPPLY RELAY VALVES	Valve Product Number	Repair Kit Number
Air Pilot type	BIA-3309-316-159E	*B-3308-316
	BAA-3309-900A BAA-3309-900P	*B-3308-316-900 *Additional solenoid parts not included in kit: P-1005-08 Solenoid Plunger P-1005-02-(Coil Code) Coil
Air Latch Pilot type	**BIA-3309-316-301ES **BAA-3309-900 **BAA-3309-900N **BAA-3309-900W **BAA-3309-900NF **BAA-3309-900PR **BAA-3309-900G	

**These valves are equipped with easy access pilot cap assemblies which can be removed with a crescent or open-end type wrench in order to remove the valve plunger assembly while the valve is still mounted in the panel.

For valves with Suffix Option -EP add -EP to product number listed above.

INDICATING RELAY Valves	Valve Product Number	Repair Kit Number
-900 type	BAA-3308-900R BAA-3308-900RA	B-3308-316-900
-550 type	BAA-3308-550R BAA-3308-550RA	B-3308-550RA
	BAA-3308-550RAB	B-3308-550RAB

For valves with Suffix Option -EP add -EP to product number listed above.