

VAVTROL[®] DN

Electronically Control Type Butterfly Valves

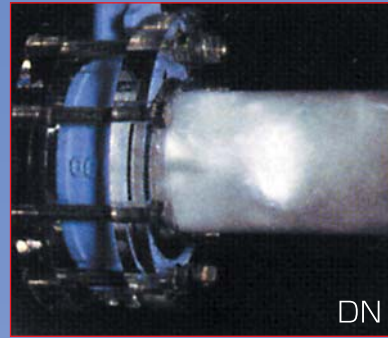

DN2P



DN

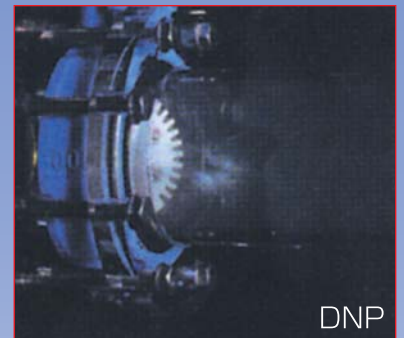

DNP

The DN series made their debut. Microprocessors are equipped on the electronic control butterfly valves, VAVTROL of OKM. They are the most advanced valves in the 21st century with high reliability and controllability unique to digital control.

**The valves have got
intelligence now.**

VAVTROL-DN Series

PATENTED

"Stainless Disk" The Valve Body for Stable Control

The high range ability (more than 1:100) extends the control range. The high choking feature enables stable control. The disk is made of stainless steel, and the inside surface in contact with the fluid will not rust.



"Touch Sheet" High Sealing Feature with a Tight Shutoff

The OKM pioneered touch sheet method allows smooth contact for the sheet, and achieves high durability and sealing capability. The VAVTROL-DN series with the close-off function can serve as a shutoff valve.

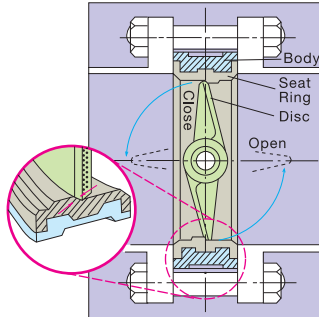

"Compact Size" Cost-saving Compact-sized Contour

Terminal block boxes and control board boxes are not required for the VAVTROL-DN series. When compared with the equal-type ML series, the DN series is 15 to 20 cm shorter in height, and more than 4 kg lighter in weight. The compact design further simplifies the piping procedures.

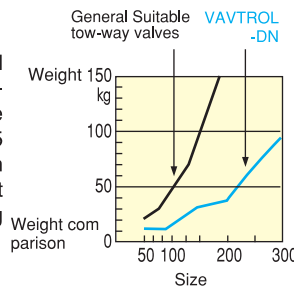

"Microcomputerized Digital Control" Realizing Accurate Operation and Easy Field Adjustments

The latest digital control increases the resolving power of the DN series from 100 : 1 to 200 : 1, making accurate control available. Field adjustments, including changing valve characteristics and functions, are also easier with the DN series. (Supporting Windows95/98)

"Communications Function" Enabling Remote Monitoring and Centralized Management

This function enables communications with external personal computers and remote monitoring computers. The loading of valve control information, changing parameters, and maintenance can be performed easily. The DN provides a new system for remote monitoring.

"Self-Controlled Operation Function" Quickly Responding to Startup and Abnormal Conditions

When the control system starts up or abnormal conditions are detected, the computer judges the conditions based on the internal condition of the driveline and communications status, and then performs predefined operations to protect the valve and system.

"Status Recording Function" Useful for Data Analysis of Abnormal Conditions

When abnormal conditions are encountered in the internal temperature or aperture, the DN saves the details into memory and sounds an external warning. It is useful for tracking down the problem and examining the responses smoothly. This feature is useful for making judgments about necessary parts replacement and lifespan during maintenance jobs. This feature is very useful for preventive maintenance of the system and system analysis when performing maintenance.

"Self-Contained Control ST Type" Operating based on the Assessment of Conditions

The ST type is an intelligent control-valve with a built-in regulator. This innovative self-contained control valve performs comparative computation of the signal from the sensor for PID control. Loading valve control information, changing parameters, and maintenance can be performed easily. The ST provides a new system for remote monitoring.

VAVTROL-DN

TYPE
DN19
On-Off type variable speed control

Use this model for on-off control. The rate of the open/close operation is easily controlled. The DN 19 prevents water hammer, and enables pressure control using a closing motion system of warmth and controlled-floating regulator when starting up an absorbing-type freezer. The valve aperture is 0 to 90°.

TYPE
DN2L
Two-way Valve Proportional Control

Use this model for general two-way valve control. There are two microcomputer-controlled models for the proportional control type: the 2L with linear flow rate characteristics, and the 2E with approximately equal characteristics. Select the type best suited to the characteristics of the control system. Generally, the 2L model is used for temperature control and liquid surface control, and the 2E model is used for pressure control and flow rate control. The characteristics can be changed after the installation to the desired settings.

TYPE
DN2E
Two-way Valve Proportional Control

The DN3 type enables proportional control for both diverted and mixed flows. Use two linear-characteristic type valves as one unit. One serves as the master-valve and receives signals from the regulator. The master-valve and sub-valve perform opposite functions to divert and mix the flow. Unlike the mixed three-way valves, the DN3 can be installed almost anywhere and minimize the capacity required for installation.

TYPE
DN3
Three-way Valve Proportional Control

VAVTROL-DN2P

TYPE
DN2P
Two-way Valve Proportional Control

The valve body features cavitation control construction so that it can be used for pressure control and other heavy control demands. The DN2P is useful for pressure control with highly different pressure, different-pressure control, and intrigue pressure control in a heat storage tank which requires preventing water from being let out.

The Self-Contained Control type is added to the line up to meet a wider range of control demands.

Function name	DN19	DN2L	DN2E	DN3	DN2P	Description
Input signal	—	○	○	○	○	Select the input signal from a 0-135Ω resistance signal, DC4-20 mA signal, and DC1 V to DC5 V. Changeable after installation.
Valve operation (forward/reverse operation)	—	○	○	○	○	Forward and reverse operation is available for the valve operation. Changes are made easily.
Interlock function	—	○	○	○	○	Select from open valve/closed valve/forceful halt/forceful halt with arbitrary aperture. Operates between the contacts and can be locked during the cable break.
Linear characteristics function	—	○	—	○	○	Changes the flow rate characteristics to be linear.
Arbitrary setting function for max/min of aperture.	—	○	○	—	○	Maximum aperture (50 to 100°C) and minimum aperture (0 to 50°C) are standard. The setting can be changed according to the circumstances.
Time adjustment for closing motion	○	—	—	—	—	Time for the closing motion can be adjusted between rapid closing (approx. 30 sec) and 10-times closing time (approx. 5 min).
Speed control function for closing motion	—	○	○	○	○	The desired speed for the closing motion can be set and changed for three individual points between the open and closed states.
Output function of valve aperture	—	○	○	○	○	Outputs a valve aperture of 0 through 100% with DC4 mA through DC20 mA. The current valve aperture can be monitored.
Medium and limit of non-voltage closing motion	○	○	○	○	○	Medium and limit of the non-voltage closing motion are standard. The limit at overload was added.
Communication function (Valve communication)	—	○	○	○	○	Data communication can be input/output from/to a personal computer for remote monitoring and centralized management.
Operational function for start up and abnormal conditions	—	○	○	○	○	Autonomously performs the predefined operation at start up and during abnormal conditions.
Status recording function	—	○	○	○	○	Saves the abnormal inner temperature and valve aperture into memory and transmits the data to external personal computers.

Standard Specifications

Valve body

Type	DN
Size	50 to 450 A
Flange	JIS10K/JIS16K/JIS20K
Maximum working voltage	1.0MPa / 1.6MPa / 2.0MPa Closed-off *1
Standard material Main unit Valve body Sheet ring Stem	FCD450 SCS13 EPDM SUS403
Ambient fluid temperature	-20 to 120°C *2

*Do not use the piping gaskets.

Supply voltage	100 VAC / 200 VAC / 220 VAC
Motor type	Condenser motor
Operation time	DN19: approx. 30 sec to 10 min. (Varies with size) Others: approx. 25 sec to 50 sec
Positioning limitation	One fully-open stopper at open-side (OLS1)
Overload limitation	One fully-closed stopper at closed-side (CTS1)
Thermal protection (combustion inhibitor)	Comes with all types. 120°C ± 10°C
Sequence output (medium limitation)	One for each side (open / closed). One for abnormal torque
Space heater	Comes with all types. (5W)
Hand-operated handle	Comes with all types. (Circular or lever type, depending on the size)
Environmental resistance	Water-proof structure for outside service Operating temperature : 0 to 50°C Vibration-proof : 1G

- *1 : A fully stainless-steel valve is also available for application in a vapor environment and refrigerant brine. Please contact us for more information. Maximum operational pressure: 1.96 MPa / 2.94 MPa
*2: Maximum operational temperature is 230 °C. Please contact us for details.

Electronically controlled unit

Power supply unit	Transformer. Built-in constant voltage circuit.
Control circuit	Microcomputer-controlled. (Built-in to the driver.)
Motor control	SSR (Non-contact relay)
Terminal box	Raceway scramble. Two G (PF) 1/2", one 3/4"

Electric Diagram

DN19 (ON-OFF Type variable speed control)

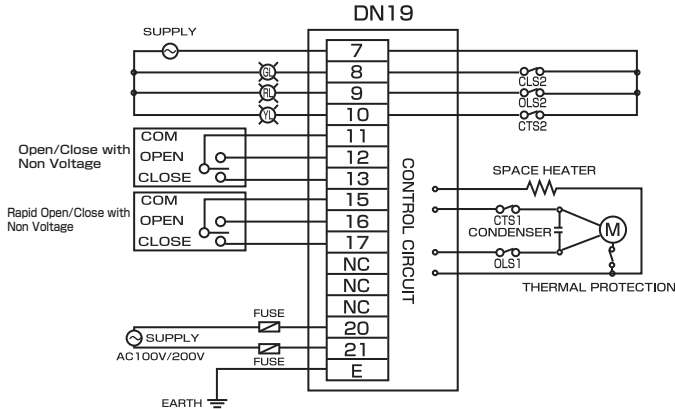

DN3 (Three-way valve proportional control)

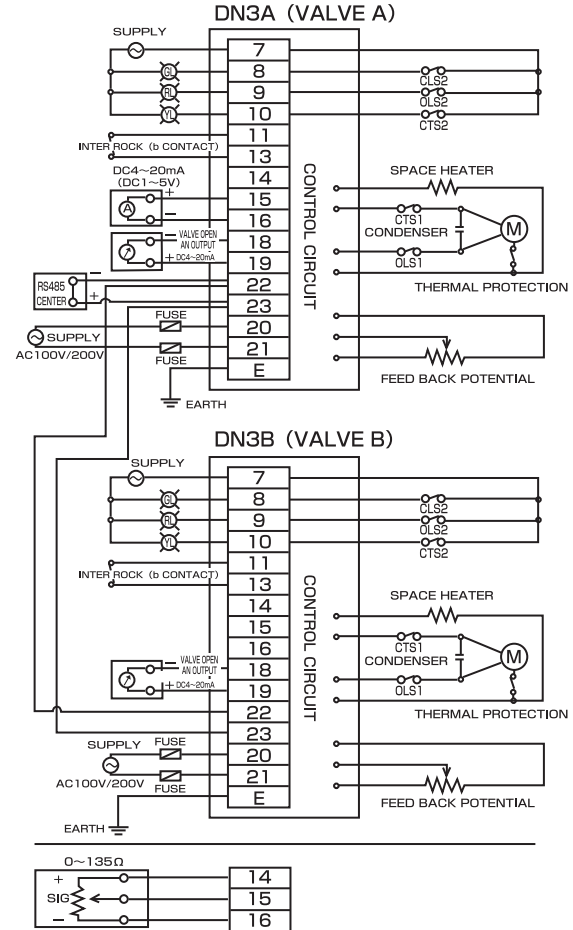

DN2L (Two-way valve proportional control) DN2E (Two-way valve proportional control)

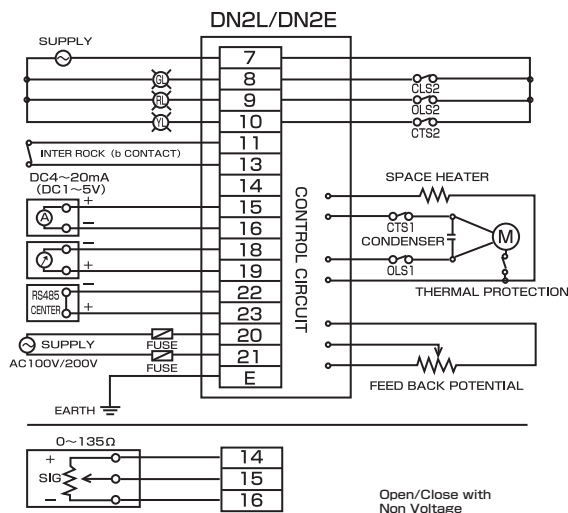

⊗ SHUT LAMP ⊗ OPEN LAMP ⊗ CLOSE TORQUE ABNORMAL LAMP

DN Series Products Names

DN2L 10 08 A B 3 2 R S

DN2L TYPE	10 Flange Standard	A Bare shaft Models	3 Power Source	R Function
DN19 : On-Off Type Variable speed control	10 : JIS10K	A : 616J (350A up 615X Type)	1 : AC100V	R : Standard Reverse Action (Signal Increase to Valve Open)
DN2E : Two-Way valve proportional control (Linear flow rate characteristics)	16 : JIS16K	B : 622H F : 5423 Q : 618P (Not Available DNS type)	2 : AC200V	D : Normal Action (Signal Increase to Valve Close)
DN2L : Two-Way valve proportional control (Approximately equal characteristics)	20 : JIS20K	C : Special G : 618H R : 541R		X : No (Only for DN19 type)
DN3 : Three-Way valve proportional control	02 : 50A	D : 5421 M : 541M T : 541T		
DN2P : Two-Way valve proportional control (Pressure Control)	03 : 80A	E : 5422 P : 616P (DN2P)		
DNOP : Option	04 : 100A			
	05 : 125A			
	06 : 150A			
	08 : 200A			
	10 : 250A			
		B Actuator Amount Direction	2 Signal	S Interlock
		A : C : Standard D :	1 : 0~135Ω (Not Available DNS type)	S : Standard Non-Load Contact Open to Valve Close
			2 : DC4~20mA	O : Standard Non-Load Contact Open to Valve Open
			3 : DC1~5V	T : Standard Non-Load Contact Open to Stop Operation by force
			X : No Signal (Only for DN19 type)	N : Standard Non-Load Contact Open to Valve Stop Operation at rated position by force
				X : NO (Only for DN19 type)

● Dimensions

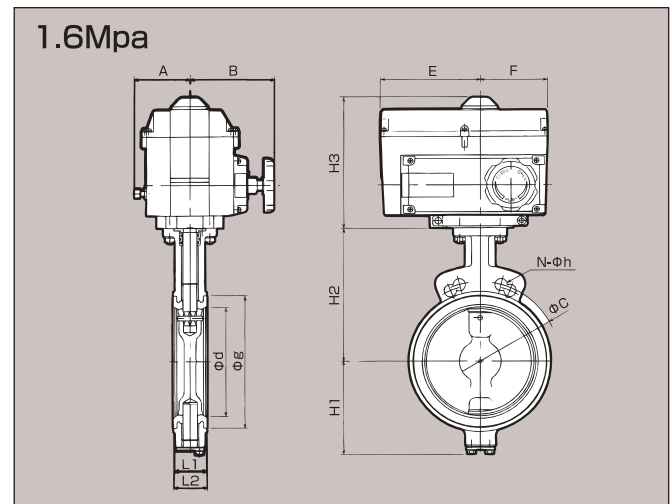
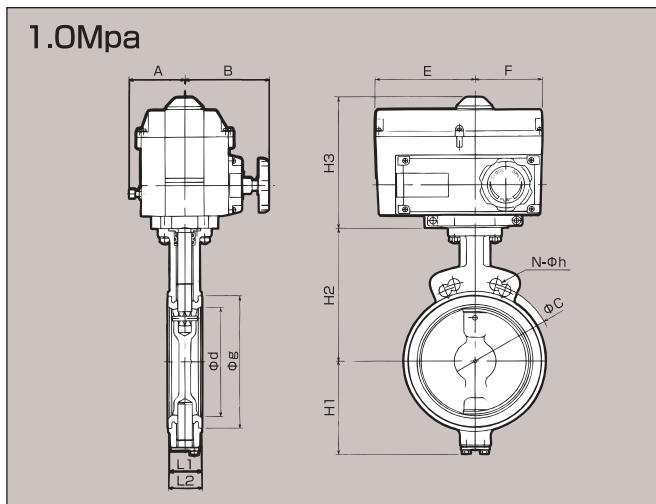

[Dimension Table of JIS10K Specifications.
Please contact us for sizes larger than 400A for JIS 16K flange.]

SIZE	d	L1	g	H1	H2	H3	A	B	E	F	ACTUATOR	WEIGHT	JIS10K		
													C	N	h
50A	55	43	81	85.5	145	220	91	145	160	117	CRV-10A	13.5	120	2/04	18
65A	66	46	99	84.5	155	220	91	145	160	117	CRV-10A	14.2	140	2/04	18
80A	84	46	114	92.5	165	220	91	145	160	117	CRV-10A	14.6	150	2/08	18
100A	100	52	136	98.5	180	220	91	145	160	117	CRV-10A	15.9	175	2/08	18
125A	130	56	167	115.5	200	220	91	145	160	117	CRV-10A	17.7	210	2/08	22
150A	154	56	192	130.5	215	220	91	145	160	117	CRV-20A	19	240	2/08	22
200A	200	60	242	168.5	245	241	100	105	177	124	CRV-40A	27.5	290	2/12	22
250A	246	68	299	203.5	283	241	100	105	177	124	CRV-60A	37.5	355	2/12	24
300A	295	78	348	253.5	316	241	100	105	177	124	CRV-60A	49	400	2/16	24
350A	336	92	389	289	330	250	177	167	195	150	CRV-100	76	445	4/16	M22
400A	390	102	448	322	370	250	177	167	195	150	CRV-150	96	510	4/16	M24
450A	439	114	504	345	400	250	177	167	195	150	CRV-150	118	565	4/20	M24

[Dimension Table of JIS20K Specifications.
Please contact us for sizes larger than 400A for JIS 16K flange.]

SIZE	d	L1	g	H1	H2	H3	A	B	E	F	ACTUATOR	WEIGHT	JIS10K		
													C	N	h
50A	55	43	81	85.5	145	220	91	145	160	117	CRV-10A	13.5	120	2/08	18
65A	66	46	99	84.5	155	220	91	145	160	117	CRV-10A	14.2	140	2/08	18
80A	84	46	114	92.5	165	220	91	145	160	117	CRV-10A	14.6	160	2/08	22
100A	100	52	136	98.5	180	220	91	145	160	117	CRV-10A	15.9	185	2/08	22
125A	130	56	167	115.5	200	220	91	145	160	117	CRV-20A	17.7	225	2/08	24
150A	154	56	192	130.5	215	220	91	145	160	117	CRV-20A	19	260	2/12	24
200A	200	60	242	168.5	245	241	100	105	177	124	CRV-40A	27.5	305	2/12	24
250A	246	68	299	203.5	283	241	100	105	177	124	CRV-60A	39.3	380	2/12	26
300A	295	78	348	253.5	313	250	177	167	195	150	CRV-100	60	430	2/16	26
350A	333	78	389	286	340	250	177	167	195	150	CRV-100	76.1	480	4/16	M30x3
400A	384	102	447	321	375	250	177	167	195	150	CRV-100	99.9	540	4/16	M30x3

● Flow Characteristics

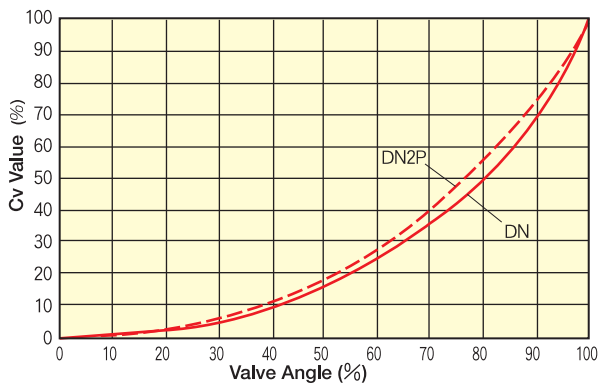

● Cavitation Factor (KC Value)

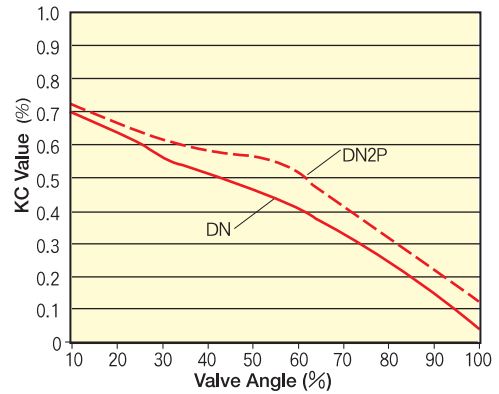

● Cv Values with Valve Fully Open (Values of 10K Specifications)

Nominal Size	DN19	DN2L, 2E	DN3	DNP
50A	165	90	90	75
65A	250	155	155	130
80A	380	180	180	150
100A	650	300	300	250
125A	1100	570	570	475
150A	1790	890	890	745
200A	3300	1420	1420	1190
250A	4820	2070	2070	1730
300A	6200	2660	2660	2225
350A	7550	5290	5290	2910
400A	10700	7500	7500	3875
450A	13800	9670	9670	—

● Pressure Recovery Factor (FL Value)

