

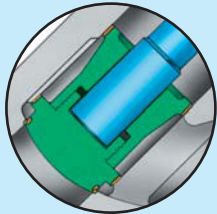

PRESSURE SEAL Y-PATTERN GLOBE VALVES CARBON, ALLOY OR STAINLESS STEEL

ASME CLASSES 900–2500

FORGED: 2½–4" (65–100 mm), CAST: 6–24" (150–600 mm)



STOP-CHECK VALVE
086P (forged)
or 086K (cast)

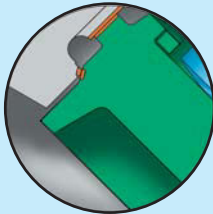

OPTIONAL SKIRTED DISC
for improved
turndown.



OPTIONAL THERMAL THRUST BOX

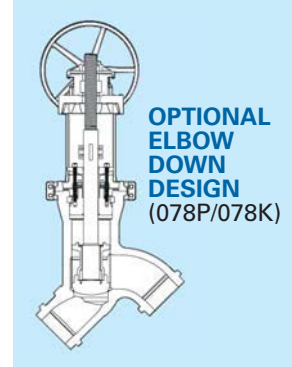

OPTIONAL ELBOW DOWN DESIGN
(078P/078K)

Note: See page 29 for other optional disc designs.

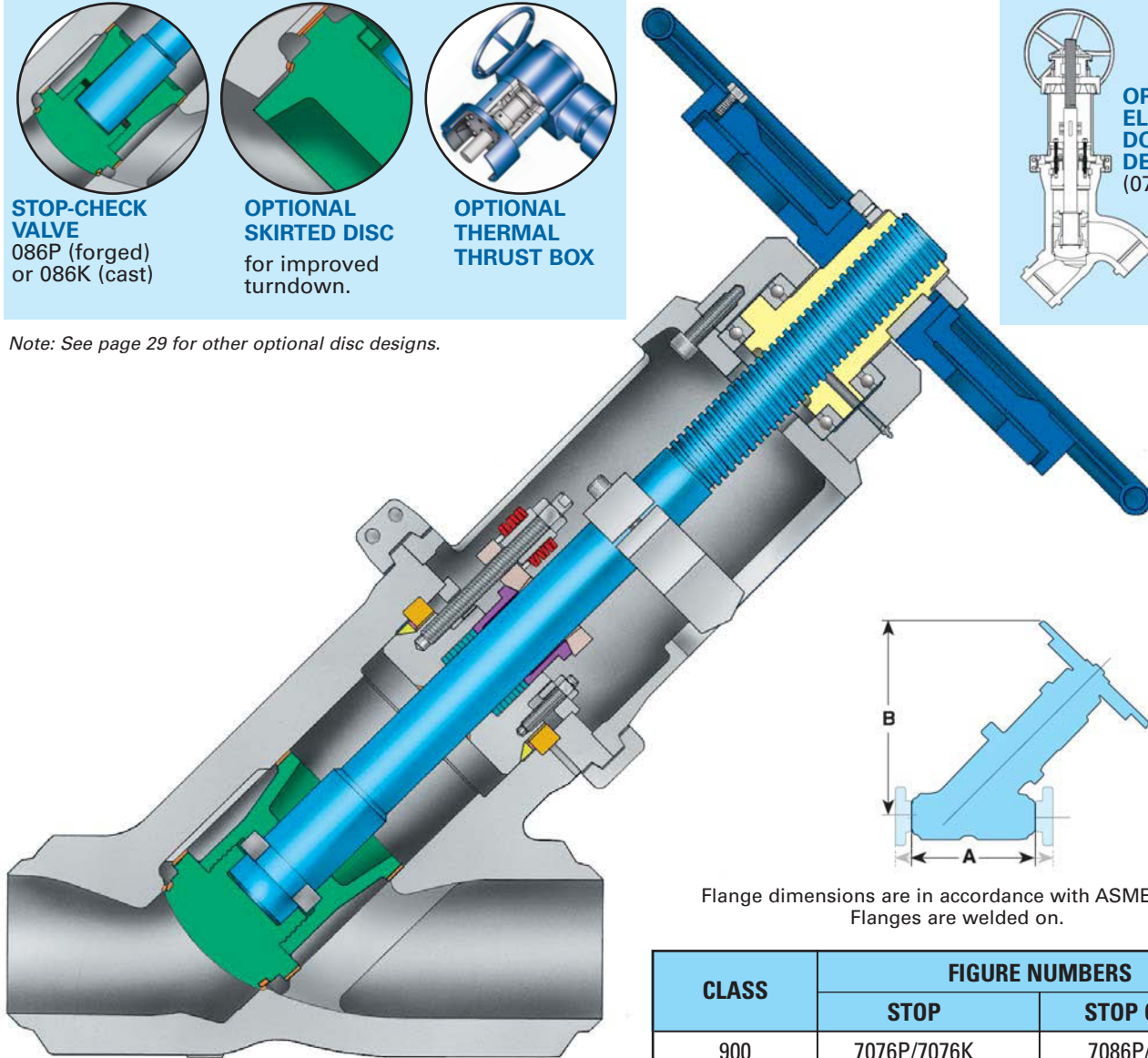

STOP VALVE 076P (forged), 076K (cast)

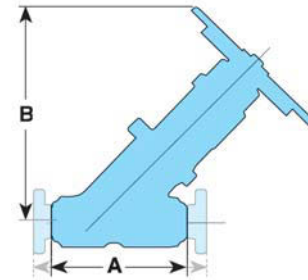

Flange dimensions are in accordance with ASME B16.5. Flanges are welded on.

CLASS	FIGURE NUMBERS	
	STOP	STOP CHECK
900	7076P/7076K	7086P/7086K
1500	3076P/3076K	3086P/3086K
2500	4076P/4076K	4086P/4086K

Note: Standard valves are reduced bore. For full bore valves, please specify at time of order

DESIGN FEATURES:

- **Velan pressure seal design.** (See page 10 for details.)
- **Low pressure drop** compared to vertical globe valves.
- **Excellent resistance** to the effects of thermal cycling.
- **Low torque stroking** due to:
 - 1) radial thrust bearings, 2) non-rotating stem,
 - 3) impactor handwheel (3–10 times more effective than standard handwheel).
- **Quick and easy repair** in line.
- **Seat integrally Stellite.**
- **Disc fully guided** with Stellite seating and guiding surfaces.
- **Tight shutoff.**
- **Stem expansion/contraction** thrust unit for high temperature application (optional).
- **Other sizes** available on request.
- **Live-loading** of packing optional.

STANDARD MATERIALS

PART	MATERIAL				
Body ⁽¹⁾⁽²⁾	A 105 or A 216 Gr. WCB	A 182 Gr. F11 or A 217 Gr. WC6	A 182 Gr. F22 or A 217 Gr. WC9	A 182 Gr. F91 A 217 C12A	A 182 Gr. F316 or A 351 Gr. CF8M
Bonnet ⁽¹⁾⁽²⁾	A 105 or A 216 Gr. WCB	A 182 Gr. F11	A 182 Gr. F22 or A 217 Gr. WC9	A 182 Gr. F91 A 217 C12A	A 182 Gr. F316 or A 351 Gr. CF8M
Disc ⁽¹⁾⁽²⁾		A 217 Gr. WC6			
Stem ⁽¹⁾⁽³⁾	Gr. 410			Gr. 616 or Gr. 660	Gr. 630 or Gr. 660
Yoke	Carbon steel				
Gasket ⁽¹⁾	Soft carbon steel–silver plated or Graphite / SS 316				
Gasket retainer	A 182 Gr. F6a Cl. 4			Gr. 616 or Gr. 660	Gr. 630 or Gr. 660
Packing ring ⁽¹⁾	Graphite				
Spacer ring ⁽¹⁾	Gr. 4140 option Ni or Cad plated or SS				
Packing flange	Carbon steel				Stainless
Gland	Carbon steel	Stainless			
Gland stud	Gr. B7				
Gland nut	Gr. 2H				
Bonnet retainer	Carbon steel	Alloy Steel			Stainless
Torque arm	Carbon steel				
Yoke bolting	Gr. B7				
Yoke nut	Manganese bronze or Austenitic Ductile Iron A 439 Gr. D-2C				
Thrust bearing	Steel				
Handwheel ⁽¹⁾	Malleable iron or steel				

(1) Other materials available, including Graphite. (2) Stellite. (3) Hardened.

Note: 2½–4" (50–100 mm) are forged. 6" (150 mm) and up are cast.

CV FLOW COEFFICIENTS*

SIZE in mm	REDUCED BORE			FULL BORE		
	Class 900	Class 1500	Class 2500	Class 900 ⁽⁴⁾	Class 1500 ⁽⁴⁾	Class 2500 ⁽⁴⁾
2½ 65	–	–	–	95	95	95
3 80	120	120	–	–	–	120
4 100	120	120	120	–	–	–
6 150	550	550	350	650	650	500
8 200	870	870	–	1300	1300	870
10 250	1400	1400	–	2050	2050	1400
12 300	1900	1900	1750	2800	2800	2050
14 350	2300	2300	2050	3000 ⁽⁵⁾	3000	2250
16 400	3000	3000	–	4850	4850	3000
18 450	4100	4100	–	4850 ⁽⁵⁾	4850 ⁽⁵⁾	3250 ⁽⁵⁾
20 500	4850	4850	3100	6350 ⁽⁵⁾	6350	4850
24 600	–	–	4850	9000 ⁽⁵⁾	7000 ⁽⁵⁾	6350

* $K_v = C_v \times 0.85$

(4) 90% or more of ASME B16.34 - Table A1 inside diameter

(5) Less than 90% of ASME B16.34 - Table A1 inside diameter

DIMENSIONS – BUTT WELD END

SIZE in mm	ASME 900/1500 (PN 150/250)			ASME 2500 (PN 420)		
	A	B	lb kg	A	B	lb kg
2½ 65	14.50 368	25.25 641	225 102	14.50 368	25.25 641	225 102
3 80	14.50 368	25.25 641	225 102	14.50 368	25.25 641	225 102
4 100	16.00 406	25.25 641	275 125	18.00 457	25.25 641	275 125
6 150	27.75 705	37.00 940	800 363	24.00 610	39.00 991	935 425
8 200	30.00 762	46.00 1168	1750 794	30.00 762	45.00 1143	1800 816
10 250	36.25 921	50.00 1270	2375 1077	36.00 914	50.00 1270	3000 1361
12 300	43.00 1092	60.00 1524	3375 1531	41.00 1041	55.00 1397	5100 2313
14 350	43.00 1092	60.00 1524	3375 1531	48.75 1238	55.00 1397	5100 2313
16 400	54.00 1372	74.00 1880	7500 3402	48.75 1238	61.00 1549	7000 3175
18 450	58.00 1473	74.00 1880	7500 3402	58.00 1473	78.00 1981	12000 5443
20 500	55.00 1397	78.00 1981	10000 4536	58.00 1473	78.00 1981	12000 5443
24 600	59.50 1511	95.00 2413	13600 6169	–	–	–