

VELAN FORGED STEEL EXTENDED BODY GATE VALVES

CONVENTIONAL PORT, THREADED OR SOCKET WELD FEMALE

NPS ½–2 (DN 15–50), API 602, ASME CLASSES 800, 1500



INTEGRALLY-REINFORCED
EXTENDED BODY – 2174W

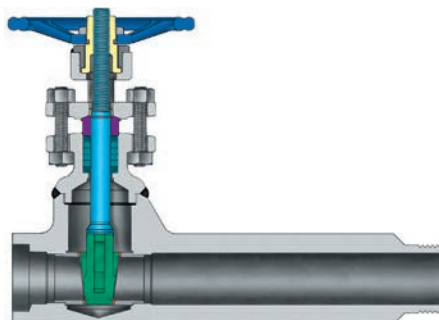

EXTENDED BODY – 2184W

PART	STANDARD MATERIALS
Body	A105
Bonnet	A105
Packing flange	A105
Seat	Gr. 410 (stainless) HF CoCr alloy
Wedge	CA15 HT or CoCr alloy
Stem	Gr. 410 (stainless)
Stem nut	Gr. 416 (stainless)
Yoke bushing	Steel
Gland	Gr. 416 (stainless)
Packing	Graphite
Gland bolt	Gr. B6 (stainless)
Gland nut	Gr. 2H
Handwheel	Malleable iron
Handwheel nut and lockwasher	Steel
Name plate	Aluminum

For other materials, trims, and engineering data, see pages 23–35.

TWO TYPES

- Complies to API 602 and ASME B16.34 standards.
- This valve is available with an extended body or an integrally-reinforced extended body (IREB).
- Extended body gate valves have a welded or NPT connection and are used for tapping of pressure vessels and header lines for vents, drains or takeoff lines and instrumentation.
- Also available: extended body assemblies for vents, drains, and instrument root valves.

AVAILABLE VARIATIONS⁽²⁾

FAMILY STANDARD END	MALE EXTENDED END	
	Standard: 2184W, 3184W	IREB: 2174W, 3174W
Thread	Couplet, NPT, or Socket	Couplet, NPT, socket weld (plain), butt weld
Socket weld	Couplet or Socket	

EXTENDED BODY GATE VALVE DIMENSIONS AND WEIGHTS

Size NPS DN	A Port		B End-to-end		C Center-to-top, closed		D Center-to-top, open		H Handwheel		K Socket weld bore	L Socket weld depth	DA Short end-to-center		DB Long end-to center		Weight lb kg	
	800 & 1500	800	1500	800	1500	800	1500	800	1500	800			1500	800	1500	800	1500	
	½ 15	0.50 ⁽¹⁾ 13	5.63 143	5.75 146	5.90 150	6.4 163	6.6 168	7.14 181	3.50 89	3.50 89	0.855 21.7	0.38 9.5	1.63 41	1.75 44	4.00 102	4.00 102	5.0 2.3	7.7 3.5
¾ 20	0.50 13	5.63 143	5.75 146	5.90 150	6.4 163	6.6 168	7.14 181	3.50 89	3.50 89	1.065 27.1	0.50 12.7	1.63 41	1.75 44	4.00 102	4.00 102	5 2.3	8.8 4.0	
1 25	0.69 18	5.75 146	7.25 184	6.4 163	8.1 206	7.4 188	8.9 226	3.50 89	4.75 121	1.33 33.8	0.50 12.7	1.75 44	2.50 64	4.00 102	4.75 121	6.1 2.8	17.00 7.7	
1¼ 32	1.25 32	7.00 178	–	7.6 193	–	9.2 234	–	4.75 121	–	1.675 42.5	0.50 12.7	2.25 57	–	4.75 121	–	13 6	–	
1½ 40	1.25 32	7.25 184	7.88 200	7.6 193	9.40 239	9.2 234	10.8 274	4.75 121	6.00 152	1.915 48.6	0.50 12.7	2.5 64	2.63 67	4.75 121	5.25 133	13.00 6	24.00 11	
2 50	1.50 38	7.88 200	12.25 311	8.8 224	12.40 315	10.50 267	14.10 358	6.00 152	10.00 254	2.406 61.1	0.63 15.9	2.63 67	5.00 127	5.25 133	7.25 184	19.00 9	55.00 25	

IREB GATE VALVE DIMENSIONS AND WEIGHTS

Size NPS DN	A Port		B End-to-end		C Center-to-top, closed		D Center-to-top, open		H Handwheel		K Socket weld bore	L Socket weld depth	DA Short end-to-center		DB Long end-to center		Weight lb kg	
	800 & 1500	800	1500	800	1500	800	1500	800	1500	800			1500	800	1500	800	1500	
	½ 15	0.50 ⁽¹⁾ 13	8.63 219	8.88 226	5.90 150	6.4 163	6.63 168	7.14 181	3.50 89	3.50 89	0.855 21.7	0.38 9.5	1.63 41	1.75 44	7.00 178	7.13 181	6.6 3.0	8.8 4.0
¾ 20	0.50 13	8.63 219	8.88 226	5.90 150	6.4 163	6.63 168	7.14 181	3.50 89	3.50 89	1.065 27.1	0.50 12.7	1.63 41	1.75 44	7.00 178	7.13 181	6.6 3.0	10 4.5	
1 25	0.69 18	9.38 238	10.13 257	6.4 163	8.1 206	7.4 188	8.9 226	3.50 89	4.75 121	1.33 33.8	0.50 12.7	1.75 44	2.50 64	7.63 194	7.63 194	7.7 3.5	20 9.1	
1¼ 32	1.25 32	10.50 266	10.63 270	7.6 193	9.4 239	9.2 234	10.8 274	4.75 121	6.00 152	1.675 42.5	0.50 12.7	2.50 64	2.63 67	8.00 203	8.00 203	15 6.8	30 14	
1½ 40	1.25 32	10.50 266	10.63 270	7.6 193	9.4 239	9.2 234	10.8 274	4.75 121	6.00 152	1.915 48.6	0.50 12.7	2.50 64	2.63 67	8.00 203	8.00 203	15 6.8	30 14	
2 50	1.50 38	11.88 302	14.25 362	8.8 224	12.4 315	10.50 267	14.1 358	6.00 152	10.00 254	2.406 61.1	0.63 15.9	2.63 67	5.00 127	9.25 235	9.25 235	25 11.3	66 30	

(1) 0.36" (9 mm) seat for ½" NPT male end only.

(2) Bolted bonnet also available.