

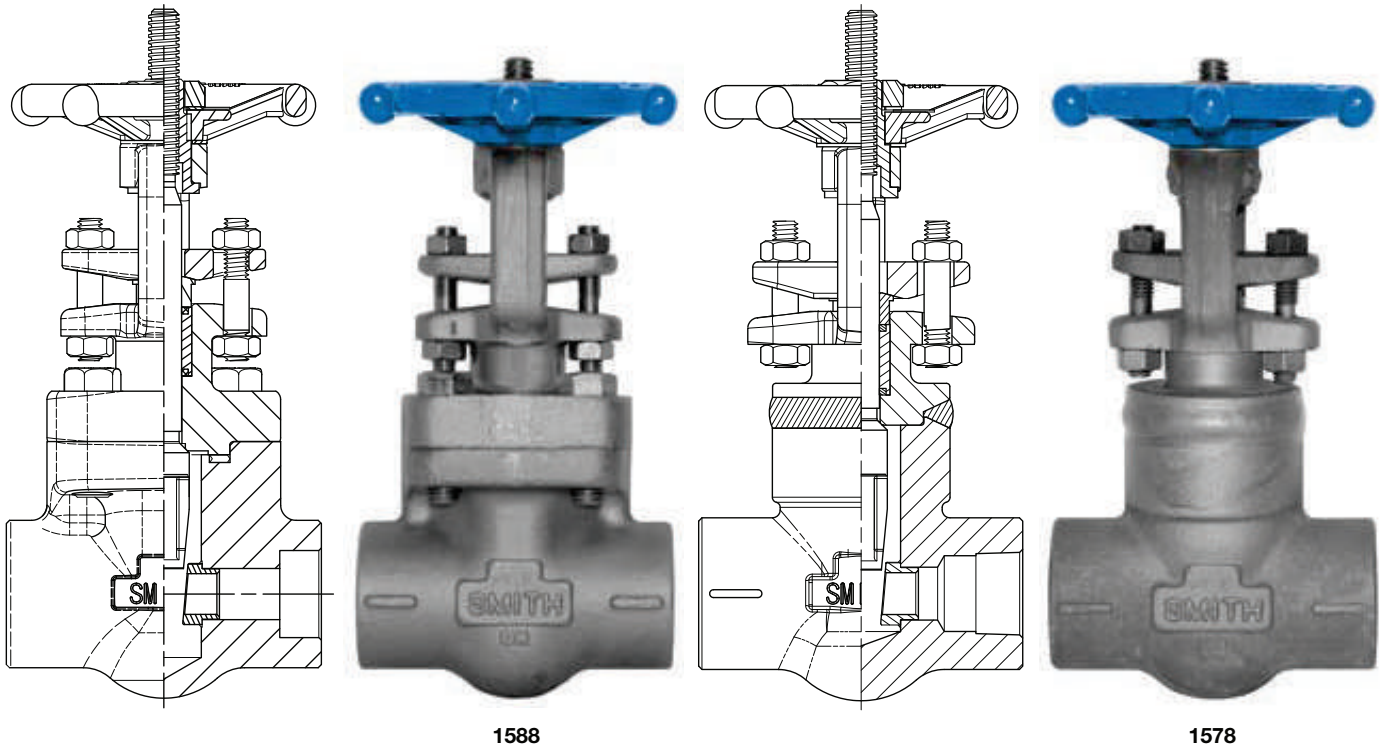

1588-1578 Gate Valves

Forged Steel OS&Y – Full Port
Valves comply with applicable portions of API 602 and ASME B16.34

Class 1500
1/4" - 1-1/2"



CLASS 1500 FULL PORT BOLTED BONNET GATE VALVE - THREADED or SOCKET WELD - INCHES (MM)

VALVE SIZE NPS (DIN)	END TO END	CENTER TO TOP (OPEN)	HANDWHEEL DIAMETER	PORT DIAMETER	SOCKET DEPTH	SOCKET DIAMETER	NPT THRD	APPROX. WEIGHT LBS (KG)
1/4 (8)	3.50 (89)	6.44 (164)	4.00 (102)	0.31 (8)	0.39 (10)	0.56 (14)	1/4"-18	5.3 (2.4)
3/8 (10)	3.50 (89)	6.50 (165)	4.00 (102)	0.39 (10)	0.39 (10)	0.69 (18)	3/8"-18	5.3 (2.4)
1/2 (15)	3.94 (100)	6.88 (175)	4.00 (102)	0.50 (13)	0.39 (10)	0.86 (22)	1/2"-14	7.5 (3.4)
3/4 (20)	4.75 (121)	8.94 (227)	4.00 (102)	0.75 (19)	0.51 (13)	1.07 (27)	3/4"-14	14.8 (6.7)
1 (25)	4.75 (121)	9.06 (230)	5.50 (140)	0.94 (24)	0.51 (13)	1.34 (34)	1"-11 1/2	23.5 (10.7)
1 1/4 (32)	5.50 (140)	11.00 (279)	6.63 (168)	1.19 (30)	0.51 (13)	1.68 (43)	1 1/4"-11 1/2	23.0 (10.4)
1 1/2 (40)	6.25 (159)	11.56 (294)	6.63 (168)	1.50 (38)	0.51 (13)	1.92 (49)	1 1/2"-11 1/2	30.5 (13.8)

CLASS 1500 FULL PORT WELDED BONNET GATE VALVE - THREADED or SOCKET WELD - INCHES (MM)

VALVE SIZE NPS (DIN)	END TO END	CENTER TO TOP (OPEN)	HANDWHEEL DIAMETER	PORT DIAMETER	SOCKET DEPTH	SOCKET DIAMETER	NPT THRD	APPROX. WEIGHT LBS (KG)
1/4 (8)	3.50 (89)	6.31 (160)	4.00 (102)	0.31 (8)	0.39 (10)	0.56 (14)	1/4"-18	4.8 (2.2)
3/8 (10)	3.50 (89)	6.38 (162)	4.00 (102)	0.39 (10)	0.39 (10)	0.69 (18)	3/8"-18	4.8 (2.2)
1/2 (15)	3.88 (98)	7.00 (178)	4.00 (102)	0.50 (13)	0.39 (10)	0.86 (22)	1/2"-14	6.3 (2.8)
3/4 (20)	4.75 (121)	8.75 (222)	4.00 (102)	0.75 (19)	0.51 (13)	1.07 (27)	3/4"-14	11.5 (5.2)
1 (25)	4.75 (121)	8.94 (227)	5.50 (140)	0.94 (24)	0.51 (13)	1.34 (34)	1"-11 1/2	19.0 (8.6)
1 1/4 (32)	5.50 (140)	10.69 (272)	6.63 (168)	1.19 (30)	0.51 (13)	1.68 (43)	1 1/4"-11 1/2	17.8 (8.1)
1 1/2 (40)	6.25 (159)	11.06 (281)	6.63 (168)	1.50 (38)	0.51 (13)	1.92 (49)	1 1/2"-11 1/2	25.0 (11.3)