

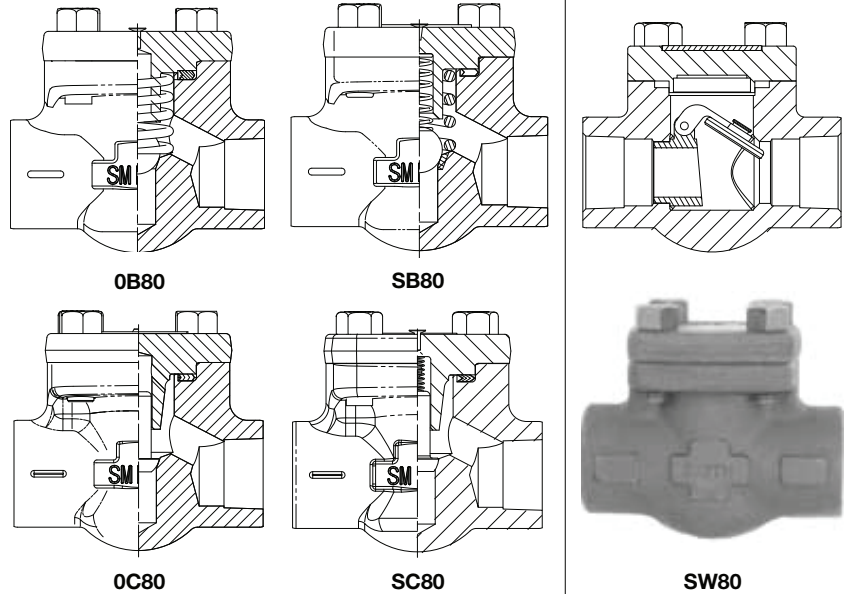

OB80-SB80-OC80-SC80-SW80 Check Valves

Forged Steel, Bolted Cap, Horizontal, Ball, Piston, Swing type
Valves comply with applicable portions of API 602 and ASME B16.34

Class 800
1/4" - 2"



OB80 CLASS 800 BOLTED CAP BALL TYPE CHECK VALVE - THREADED or SOCKET WELD - INCHES (MM)

VALVE SIZE NPS (DIN)	END TO END	CENTER TO TOP (OPEN)	PORT DIAMETER	SOCKET DEPTH	SOCKET DIAMETER	NPT THRD	APPROX. WEIGHT LBS (KG)	CRACKING PRESSURE PSI (BAR)
1/4 (8)	3.25 (83)	2.00 (51)	0.25 (6)	0.39 (10)	0.56 (14)	1/4"-18	2.5 (1.1)	0.2 (0.01)
3/8 (10)	3.25 (83)	2.00 (51)	0.25 (6)	0.39 (10)	0.69 (18)	3/8"-18	2.5 (1.1)	0.2 (0.01)
1/2 (15)	3.25 (83)	2.00 (51)	0.38 (10)	0.39 (10)	0.86 (22)	1/2"-14	2.3 (1.0)	0.2 (0.01)
3/4 (20)	3.50 (89)	2.25 (57)	0.50 (13)	0.51 (13)	1.07 (27)	3/4"-14	3.3 (1.5)	0.3 (0.02)
1 (25)	4.50 (114)	2.25 (57)	0.75 (19)	0.51 (13)	1.34 (34)	1"-11 1/2	5.0 (2.3)	0.3 (0.02)
1 1/4 (32)	6.25 (159)	2.88 (73)	1.00 (25)	0.51 (13)	1.68 (43)	1 1/4"-11 1/2	10.5 (4.8)	0.4 (0.03)
1 1/2 (40)	6.25 (159)	2.88 (73)	1.19 (30)	0.51 (13)	1.92 (49)	1 1/2"-11 1/2	10.0 (4.5)	0.4 (0.03)
2 (50)	7.25 (184)	3.56 (90)	1.44 (37)	0.63 (16)	2.41 (61)	2"-11 1/2	18.2 (8.3)	0.5 (0.03)

SB80 CLASS 800 BOLTED CAP SPRING BALL TYPE CHECK VALVE - THREADED or SOCKET WELD - INCHES (MM)

VALVE SIZE NPS (DIN)	END TO END	CENTER TO TOP (OPEN)	PORT DIAMETER	SOCKET DEPTH	SOCKET DIAMETER	NPT THRD	APPROX. WEIGHT LBS (KG)	CRACKING PRESSURE PSI (BAR)
1/4 (8)	3.25 (83)	2.00 (51)	0.25 (6)	0.39 (10)	0.56 (14)	1/4"-18	2.5 (1.1)	2.1 (0.14)
3/8 (10)	3.25 (83)	2.00 (51)	0.25 (6)	0.39 (10)	0.69 (18)	3/8"-18	2.5 (1.1)	2.1 (0.14)
1/2 (15)	3.25 (83)	2.00 (51)	0.38 (10)	0.39 (10)	0.86 (22)	1/2"-14	2.3 (1.0)	2.1 (0.14)
3/4 (20)	3.50 (89)	2.25 (57)	0.50 (13)	0.51 (13)	1.07 (27)	3/4"-14	3.3 (1.5)	2.1 (0.14)
1 (25)	4.50 (114)	2.25 (57)	0.75 (19)	0.51 (13)	1.34 (34)	1"-11 1/2	5.0 (2.3)	3.5 (0.24)
1 1/4 (32)	6.25 (159)	2.88 (73)	1.00 (25)	0.51 (13)	1.68 (43)	1 1/4"-11 1/2	10.5 (4.8)	2.7 (0.19)
1 1/2 (40)	6.25 (159)	2.88 (73)	1.19 (30)	0.51 (13)	1.92 (49)	1 1/2"-11 1/2	10.0 (4.5)	2.7 (0.19)
2 (50)	7.25 (184)	3.56 (90)	1.44 (37)	0.63 (16)	2.41 (61)	2"-11 1/2	18.2 (8.3)	6.0 (0.41)



OB80-SB80-OC80-SC80-SW80 Check Valves

Forged Steel, Bolted Cap, Horizontal, Ball, Piston, Swing type
Valves comply with applicable portions of API 602 and ASME B16.34

Class 800
1/4" - 2"

OC80 CLASS 800 BOLTED CAP PISTON TYPE CHECK VALVE - THREADED or SOCKET WELD - INCHES (MM)								
VALVE SIZE NPS (DIN)	END TO END	CENTER TO TOP (OPEN)	PORT DIAMETER	SOCKET DEPTH	SOCKET DIAMETER	NPT THRD	APPROX. WEIGHT LBS (KG)	CRACKING PRESSURE PSI (BAR)
1/4 (8)	3.25 (83)	2.00 (51)	0.25 (6)	0.39 (10)	0.56 (14)	1/4"-18	2.5 (1.1)	0.3 (0.02)
3/8 (10)	3.25 (83)	2.00 (51)	0.25 (6)	0.39 (10)	0.69 (18)	3/8"-18	2.5 (1.1)	0.3 (0.02)
1/2 (15)	3.25 (83)	2.00 (51)	0.38 (10)	0.39 (10)	0.86 (22)	1/2"-14	2.3 (1.0)	0.3 (0.02)
3/4 (20)	3.50 (89)	2.25 (57)	0.50 (13)	0.51 (13)	1.07 (27)	3/4"-14	3.3 (1.5)	0.3 (0.02)
1 (25)	4.50 (114)	2.25 (57)	0.75 (19)	0.51 (13)	1.34 (34)	1"-11 1/2	5.0 (2.3)	0.3 (0.02)
1 1/4 (32)	6.25 (159)	2.88 (73)	1.00 (25)	0.51 (13)	1.68 (43)	1 1/4"-11 1/2	10.5 (4.8)	0.3 (0.02)
1 1/2 (40)	6.25 (159)	2.88 (73)	1.19 (30)	0.51 (13)	1.92 (49)	1 1/2"-11 1/2	10.0 (4.5)	0.3 (0.02)
2 (50)	7.25 (184)	3.56 (90)	1.44 (37)	0.63 (16)	2.41 (61)	2"-11 1/2	18.2 (8.3)	0.4 (0.03)

SC80 CLASS 800 BOLTED CAP SPRING PISTON TYPE CHECK VALVE - THREADED or SOCKET WELD - INCHES (MM)								
VALVE SIZE NPS (DIN)	END TO END	CENTER TO TOP (OPEN)	PORT DIAMETER	SOCKET DEPTH	SOCKET DIAMETER	NPT THRD	APPROX. WEIGHT LBS (KG)	CRACKING PRESSURE PSI (BAR)
1/4 (8)	3.25 (83)	2.00 (51)	0.25 (6)	0.39 (10)	0.56 (14)	1/4"-18	2.5 (1.1)	1.8 (0.12)
3/8 (10)	3.25 (83)	2.00 (51)	0.25 (6)	0.39 (10)	0.69 (18)	3/8"-18	2.5 (1.1)	1.8 (0.12)
1/2 (15)	3.25 (83)	2.00 (51)	0.38 (10)	0.39 (10)	0.86 (22)	1/2"-14	2.3 (1.0)	1.8 (0.12)
3/4 (20)	3.50 (89)	2.25 (57)	0.50 (13)	0.51 (13)	1.07 (27)	3/4"-14	3.3 (1.5)	1.0 (0.07)
1 (25)	4.50 (114)	2.25 (57)	0.75 (19)	0.51 (13)	1.34 (34)	1"-11 1/2	5.0 (2.3)	0.6 (0.04)
1 1/4 (32)	6.25 (159)	2.88 (73)	1.00 (25)	0.51 (13)	1.68 (43)	1 1/4"-11 1/2	10.5 (4.8)	0.5 (0.03)
1 1/2 (40)	6.25 (159)	2.88 (73)	1.19 (30)	0.51 (13)	1.92 (49)	1 1/2"-11 1/2	10.0 (4.5)	0.5 (0.03)
2 (50)	7.25 (184)	3.56 (90)	1.44 (37)	0.63 (16)	2.41 (61)	2"-11 1/2	18.2 (8.3)	0.7 (0.05)

SW80 CLASS 800 BOLTED CAP SWING TYPE CHECK VALVE - THREADED or SOCKET WELD - INCHES (MM)								
VALVE SIZE NPS (DIN)	END TO END	CENTER TO TOP (OPEN)	PORT DIAMETER	SOCKET DEPTH	SOCKET DIAMETER	NPT THRD	APPROX. WEIGHT LBS (KG)	CRACKING PRESSURE PSI (BAR)
1/2 (15)	3.25 (83)	2.00 (51)	0.38 (10)	0.39 (10)	0.86 (22)	1/2"-14	2.1 (1.0)	0.1 (0.01)
3/4 (20)	3.50 (89)	2.25 (57)	0.50 (13)	0.51 (13)	1.07 (27)	3/4"-14	3.1 (1.4)	0.1 (0.01)
1 (25)	3.88 (98)	2.63 (67)	0.75 (19)	0.51 (13)	1.34 (34)	1"-11 1/2	4.5 (2.0)	0.1 (0.01)
1 1/2 (40)	4.75 (121)	3.75 (95)	1.19 (30)	0.51 (13)	1.92 (49)	1 1/2"-11 1/2	8.6 (3.9)	0.1 (0.01)
2 (50)	5.50 (140)	4.50 (114)	1.50 (38)	0.63 (16)	2.41 (61)	2"-11 1/2	16.0 (7.3)	0.1 (0.01)