

# PRESSURE SEAL NON-RETURN VALVES

CAST CARBOB, STAINLESS STEEL OR ALLOY STEEL

2 - 12" (50 - 300 mm)

ASME CLASSES 600 - 2500

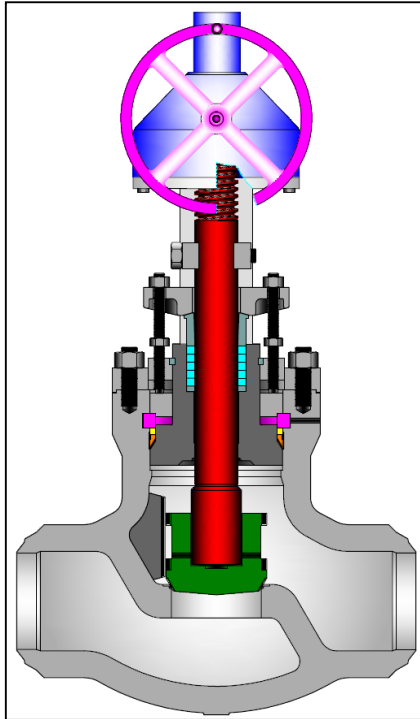

Class	Fig. No.
600	1684
900	1984
1500	1184
2500	1284

### DESIGN FEATURES:

- Standard trim is stellite faced seat and disc seat surfaces, and 13% chrome stem (API trim 5). Other trims available on request.
- Valves are full port design per ASME B16.34 Table A-1.
- Wall thickness per heavy wall API 600 requirements.
- Seat faces lapped for smooth finish and superior sealing.
- Each valve is shell, seat and backseat pressure tested per industry standard API 598.
- Gland is two piece gland / gland flange design for optimal alignment and uniform packing compression.
- Weld end valves are B16.10 short pattern design. Flanged end valves are B16.10 long-pattern design. Weld end valve dimensions given in table on next page.
- Valve sizes 4" and smaller have bonnet take up ring design instead of support plate design.

### STANDARD MATERIALS (Other materials available)

PART	MATERIALS			
Body	A216 Gr. WCB (STANDARD)	A217 Gr. WC6	A217 Gr. WC9	A217 Gr. C12A
Bonnet	A105	A182 F11	A182 F22	A182 F91
Yokearm	A216 Gr. WCB			
Disc	A105 or A216 WCB + Stellite 6 Faced	A182 F11 or A217 WC6 + Stellite 6 Faced	A182 F22 or A217 WC9 + Stellite 6 Faced	A182 F91 or A217 WC9 + Stellite 6 Faced
Seat Ring	Carbon Steel + Stellite 6 Faced	A182 F11 + Stellite 6 Faced	A182 F22 + Stellite 6 Faced	A182 F91 + Stellite 6 Faced
Stem	A182 F6a			
Stem Bushing	A 439 Ductile NI-Resist Gr. D2			
Stem Bushing Set Screw	Steel			
Gland Flange	A216 Gr. WCB			
Eye Bolt	A193 Gr. B7			
Eye Bolt Nut	A194 Gr. 2H			
Groove Pin	Steel			
Gland	SST 410			
Packing	Graphite			
Packing Washer / Packing Spacer	SST 410			
Protective Ring	SST 410			
Segmental Thrust Ring	SST 410			
Support Plate	Steel			
Gasket	SST 304L			
Hand Wheel	Malleable Iron or Steel			
Hand Wheel Nut	Steel			
Body / Bonnet / Yoke Stud	A193 Gr. B7	A193 Gr. B16		
Body / Bonnet / Yoke Nut	A194 Gr. 2H	A194 Gr. 7		

- Each valve has a unique certification number that is traceable to the valve certification sheet which includes MTR data, pressure test, inspection result and certificate of conformance.
- Other available options as follows:
  - » Alternate valve materials such as chrome and stainless steel alloys
  - » Alternate trim materials
  - » Bypass, drain and other auxiliary connections
  - » Gear, motor, and cylinder actuators available
  - » NACE service
  - » Special cleaning for applications such as oxygen or chlorine
  - » Other options available as specified

### Design Specifications

Item	Applicable Specification
Wall thickness	API 600
Pressure - temperature ratings	ASME B16.34
General valve design	B16.34
End to End dimensions	ASME B16.10
Flange design	ASME B16.5
Butt Weld design	ASME B16.25
Materials	ASTM

**Note:** Angle pattern available on request.

# NON-RETURN VALVE DIMENSIONS

(CLASSES 600 - 2500)

SIZE	ASME 600					ASME 900					ASME 1500				
	in	A	B(1)	C(1)	D	E	A	B(1)	C(1)	D	E	A	B(1)	C(1)	D
2	7.0	15.9	16.5	2.00	10.0	8.5	15.9	16.5	1.87	12.0	8.5	18.0	18.8	1.87	12.0
50	178	405	420	51	250	216	405	420	48	300	216	460	475	48	300
2½	8.5	17.1	18.0	2.50	12.0	10.0	17.9	18.8	2.25	14.0	10.0	19.9	20.8	2.25	18.0
65	216	435	460	64	300	254	455	475	57	350	254	505	525	57	450
3	10.0	18.5	19.5	3.00	12.0	12.0	21.0	22.0	2.87	14.0	12.0	23.3	24.3	2.75	22.0
80	254	470	495	76	300	305	535	560	73	350	305	590	615	70	550
4	12.0	22.1	23.5	4.00	18.0	14.0	25.1	26.5	3.87	18.0	16.0	29.3		3.62	18.0
100	305	560	600	102	450	356	640	675	98	450	406	745		92	460
6	18.0	28.0	30.0	6.00	20.0	20.0	36.5		5.75	24.0	22.0	40.3		5.37	24.0
150	457	710	760	152	500	508	925		146	610	559	1025		136	610
8	23.0	40.0	42.8	7.87	24.0	26.0	52.5		7.50	24.0	28.0	55.0		7.00	24.0
200	584	1015	1085	200	600	660	1335		191	610	711	1400		178	610
10	28.0	50.0		9.75	24.0	31.0	56.5		9.37	24.0	34.0	62.5		8.75	24.0
250	711	1270		248	610	787	1435		238	610	864	1590		222	610
12	32.0	55.5		11.75	24.0	36.0	59.3		11.12	24.0	39.0	70.0		10.37	32.0
300	813	1410		298	610	914	1505		282	610	991	1780		263	800

(1) Gear operators standard for 10" and up for class 600, 6" and up for class 900, and 4" and up for class 1500 and 2500.

SIZE	ASME 2500				
	in	A	B(1)	C(1)	D
2	11.0	19.0	19.8	1.5	22.0
50	279	485	500	38	550
2½	13.0	22.0	22.8	1.87	24.0
65	330	560	580	48	600
3	14.5	23.8	24.8	2.25	24.0
80	368	605	630	57	600
4	18.0	31.0		2.87	18.0
100	457	790		73	460
6	24.0	47.3		4.37	24.0
150	610	1200		111	610
8	30.0	61.8		5.75	24.0
200	762	1570		146	610
10	36.0	69.5		7.25	24.0
250	914	1765		184	610
12	41.0	80.0		8.62	32.0
300	1041	2030		219	800

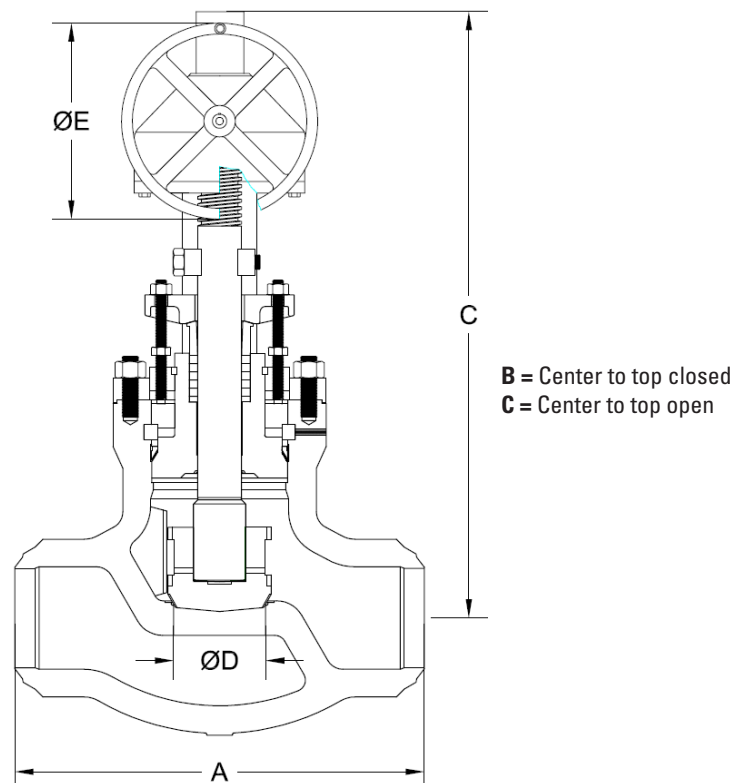

# PRESSURE SEAL NON-RETURN VALVES

CAST CARBON, STAINLESS STEEL OR ALLOY STEEL

2 - 12" (5 - 300 mm)

ASME CLASSES 600 - 2500

SIZE	ASME 600					ASME 900					ASME 1500					ASME 2500				
	F	in	WT	lb	CV	F	in	WT	lb	CV	F	in	WT	lb	CV	F	in	WT	lb	CV
mm		mm	kg				mm		kg			mm		kg			mm		kg	
2	25.4		46		50	26.7		80		40	27.7		85		40	30.3		111		25
50	645		21			678		36			700		39			770		50		
2½	25.4		83		75	26.7		120		60	29.6		136		60	31.0		169		40
65	645		38			678		54			746		62			787		77		
3	27.7		106		110	30.9		187		100	32.3		199		90	33.8		261		60
80	704		48			784		85			820		90			859		118		
4	32.0		182		200	36.0		288		190	40.0		430		160	41.5		567		100
100	814		83			916		131			1017		195			1057		257		
6	38.9		359		480	45.9		624		440	49.1		922		380	59.9		1240		250
150	987		163			1164		283			1248		418			1522		562		
8	51.5		581		850	62.6		1042		770	65.6		1521		670	70.8		2056		450
200	1306		263			1592		473			1668		690			1799		932		
10	61.6		843		1300	67.8		1576		1200	72.9		2468		1000	88.2		3378		720
250	1562		382			1722		715			1854		1119			2239		1532		
12	68.8		1144		2000	71.8		2210		1800	83.2		3613		1500	97.9		4056		1100
300	1746		519			1824		1002			2114		1639			2487		1839		

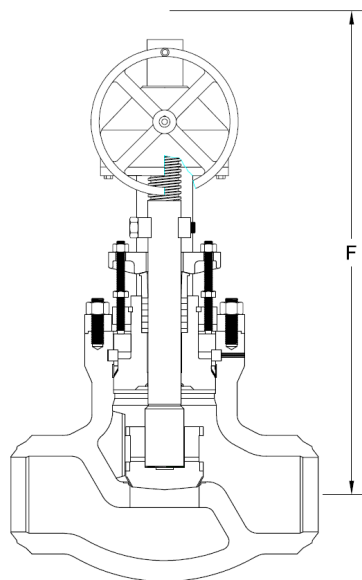

**F** = Dismantling dimension

**WT** = Weight

**CV** = Flow coefficient