

STOP VALVE zGLO



Body material	Nominal pressure	Nominal diameter	Max. temperature
A Grey cast iron	A 6 bar C 16 bar	DN 15-300	300°C
C Nodular cast iron	C 16 bar D 25 bar	DN 15-200 DN 15-80	350°C
E Bronze	C 16 bar B 10 bar A 6 bar	DN 15-125 DN 150-200 DN 250-300	225°C



correspond to the pressure equipment directive 2014/68/UE marking CE for DN≥32

FEATURES

- high tightness (leakproofness class - A acc. to EN -12266 - 1)
- compact settlement
- environment-friendly
- tests acc. to EN - 12266 - 1
- flanges drilled according to EN 1092-2 (A,C)
- flanges drilled according to EN 1092-3 (E)
- face-to-face dimension according to EN 558 series 8

APPLICATION*

*not all of the applications are suitable for all of the executions

industries							
	INDUSTRY	SHIPBUILDING INDUSTRY	HEATING	REFRIGERATION AND AIR CONDITIONING			
	media						
		GLYCOL	INDUSTRIAL WATER	DIATHERMIC OIL	STEAM	COMPRESSED AIR	NEUTRAL FLUIDS

Data given can be changed without notice.

Edition 01/2018

FIG.216

MATERIALS, DIMENSIONS

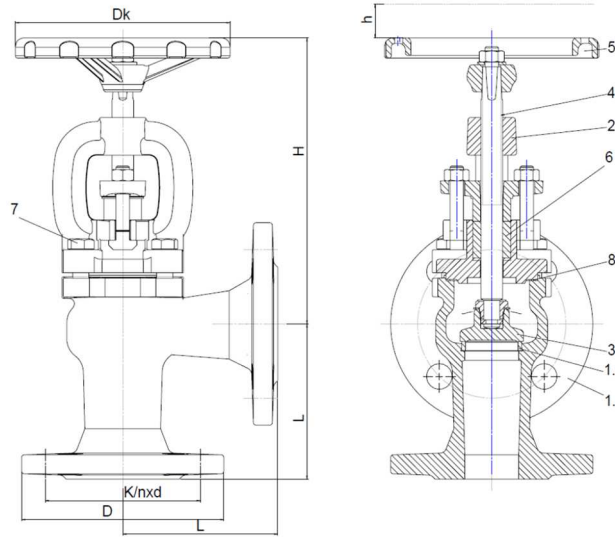

	Body material	A				C			E
		00	01 04 71 91	02 05 72 92	03 13	01 04 71 91	02 05 72 92	03 13	03 23 73 93
1.1	Body	EN – GJL-250 5.1301 (ex. J11040)				EN – GJS-400 – 18-LT 5.3103 (ex. JS1025)			CuSn5Zn5Pb5-C CC491K
1.2	Seat ring	X12Cr13 1.4021	CuSn10 – C CC480K			X12Cr13 1.4021	CuSn10 – C CC480K		CuSn5Zn5Pb5-C CC491K
2	Bonnet	EN-GJL-250 5.1301 (ex. J11040)				EN – GJS-400 – 18-LT 5.3103 (ex. JS1025)			CuSn5Zn5Pb5-C CC491K
3	Disc	X20Cr13+QT 1.4021	CuSn10 – C CC480K			X20Cr13+QT 1.4021	CuSn10 – C CC480K		CuSn5Zn5Pb5-C CC491K
4	Stem	X20Cr13 1.4021	CuZn40Mn1,5	CuSn10 – C CC480K	X20Cr13 1.4021	CuZn40Mn1,5	CuSn10 – C CC480K	CuZn35Ni	
5	Hand-wheel	EN-GJS500-7 5.3200 (ex. JS1050)							
6	Gland packing	Graphite							
7	Hexagon bolt	5.6				A2-70	5.6		A2-70
8	Gasket	Graphite + NiCr							
	Max. temperature	300°C	300°C	225°C	350°C	225°C	225°C	225°C	

Data given can be changed without notice.

Edition 01/2018

FIG.216



DN	15	20	25	32	40	50	65	80	100	125	150	200	250	300	
L (mm)	90	95	100	105	115	125	145	155	175	200	225	275	325	375	
Dk (mm)	100		120		160		180		200		250		320		
	03, 23, 73, 93		100		125		160		200		250		315		
H	163	160	173	173	214	211	236	250	301	339	383	455	531	710	
	E	160	170	170	190	210	220	260	280	300	340	360	440	550	620
	91	179	176	198	206	232	235	269	290	336	374	433	625	720	779
h (mm)	5	5,5	7	14	20	25	35	41	31	48	54	77	120	120	
	E	6	7	8	10	12	15	19	24	28	36	40	56	65	80
	71 91	14	14	25	30	24	32	42	48	50	50	60	80	100	100
k _{vs} (m ³ /h)	01 04	7,2	9,2	16	22	37	51	98,5	143	226	281	455	860	1260	2130
	E	7	10	15	27	39	71	108	150	235	360	510	905	1430	2040
Weight (kg)															
216	3,3	3,9	5	6,6	8,4	12	17,3	22,7	35,8	52,8	74,2	126	200	250	
	E	3,8	4	5	7	9	11	16	20	25	40	50	95	155	225
	31	3,1	3,5	4,8	6,6	8,7	11,8	14	20,5	32,2	46	62	126	200	250
	71	3,1	3,5	4,8	6,6	8,8	12,3	14,3	21,8	33,2	45,8	64,3	126	200	250
	91	3,1	3,5	4,8	6,6	8,8	12,3	14,3	21,8	33,2	45,8	64,3	126	200	250

KV [m³/h] FIG. 216-71, 91

Turn	DN 15	DN 20	DN 25	DN 32	DN 40	DN 50	DN 65	DN 80	DN 100	DN 125	DN 150	DN 200	DN 250	DN 300
0,5	1,59	1,55	1,06	2,10	4,1	7,2	9,1	11,2	20,2	20	25			
1	1,92	1,89	1,94	3,14	6,9	9,9	12,0	14,9	30,1	34	45	90	108	164
1,5	2,27	2,32												
2	2,61	2,75	3,59	5,19	11,2	16,3	20,8	25,7	48,9	63	87	153	191	306
2,5	2,94	3,17												
3	3,26	3,59	5,14	7,22	16,5	22,8	29,1	36,4	66,2	91	126	216	271	425
3,5	3,66	4,04												
4	4,07	4,60	6,42	9,18	21,4	28,9	37,4	46,7	82	118	162	277	347	525
4,5	4,55	5,35												
4,7	4,74	5,64												
5			7,65	11,0	27,4	35,4	45,4	56,6	97	146	199	337	420	627
6			8,71	12,8	33,8	43,5	53,1	66	113	176	235	395	489	723
7			9,57	14,5		51,8	61,2	77	135	212	271	454	556	822
8			11,88	16,1		58,1	70,9	89	161	250	308	511	622	926
8,33			12,53											
9				17,8			81,3	104	187	285	347	573	687	1021
10				20,0			90,5	119	210	314	387	633	754	1131
10,5							94,3							
11								132			421	690	822	1236
12								143			454	738	898	1340
13												762	967	1446
13,33												763		
14													1037	1543
15													1101	1637
16													1147	1717
16,66													1198	1764

Data given can be changed without notice.

Edition 01/2018

ZETKAMA Sp. z o.o.
Ul. 3 Maja 12
PL 57-410 Ścinawka Średnia

Tel. +48 74 8652 193
Tel. +48 74 8652 111
Fax +48 74 8652 199

E-mail export@zetskama.com.pl
www.zetskama.com

PRESSURE-TEMPERATURE RATINGS

Acc. EN 1092-2	PN		10°C±120°C	150°C	200°C	250°C	300°C	350°C	400°C	450°C
EN-GJL250	6	bar	6	5,4	4,8	4,2	3,6	---	---	---
	16		16	14,4	12,8	11,2	9,6	---	---	---
EN-GJS400-18 LT	16		16	15,5	14,7	13,9	12,8	11,2	---	---
	25		25	24,3	23	21,8	20	17,5	---	---
	PN		-10-120°C	150°C	180°C	200°C	225°C	350°C	400°C	450°C
CuSn5ZN5Pb5-C	16	bar	16	10	10	10	10	-----	-----	-----
	10		10	6	6	6	6	-----	-----	-----
	6		6	4	4	4	4	-----	-----	-----

FLANGE DIMENSIONS ACC. PN-EN 1092-2 (A, C)

DN		15	20	25	32	40	50	65	80	100	125	150	200	250	300
PN6	D (mm)	80	90	100	120	130	140	160	190	210	240	265	320	-----	-----
	K (mm)	55	65	75	90	100	110	130	150	170	200	225	280	-----	-----
	nxd (mm)	4x11	4x11	4x11	4x14	4x14	4x14	4x14	4x14	4x18	4x18	8x18	8x18	8x18	-----
PN16	D (mm)	95	105	115	140	150	165	185	200	220	250	285	340	405	460
	K (mm)	65	75	85	100	110	125	145	160	180	210	240	295	355	410
	nxd (mm)	4x14	4x14	4x14	4x19	4x19	4x19	4x19	8x19	8x19	8x19	8x23	12x23	12x28	12x28
PN25	D (mm)	95	105	115	140	150	165	185	200	-----	-----	-----	-----	-----	-----
	K (mm)	65	75	85	100	110	125	145	160	-----	-----	-----	-----	-----	-----
	nxd (mm)	4x14	4x14	4x14	4x19	4x19	4x19	8x19	8x19	-----	-----	-----	-----	-----	-----

FLANGE DIMENSIONS ACC. PN-EN 1092-3 (E)

DN		15	20	25	32	40	50	65	80	100	125	150	200	250	300
PN6	D (mm)	-----	-----	-----	-----	-----	-----	-----	-----	-----	-----	-----	-----	395	445
	K (mm)	-----	-----	-----	-----	-----	-----	-----	-----	-----	-----	-----	-----	350	400
	nxd (mm)	-----	-----	-----	-----	-----	-----	-----	-----	-----	-----	-----	-----	12x22	12x22
PN10	D (mm)	-----	-----	-----	-----	-----	-----	-----	-----	-----	-----	285	340	-----	-----
	K (mm)	-----	-----	-----	-----	-----	-----	-----	-----	-----	-----	240	295	-----	-----
	nxd (mm)	-----	-----	-----	-----	-----	-----	-----	-----	-----	-----	8x22	8x22	-----	-----
PN16	D (mm)	95	105	115	140	150	165	185	200	220	250	-----	-----	-----	-----
	K (mm)	65	75	85	100	110	125	145	160	180	210	-----	-----	-----	-----
	nxd (mm)	4x14	4x14	4x14	4x19	4x18	4x18	4x18	8x18	8x18	8x18	-----	-----	-----	-----

Data given can be changed without notice.

Edition 01/2018

DISC

type 04 05 13

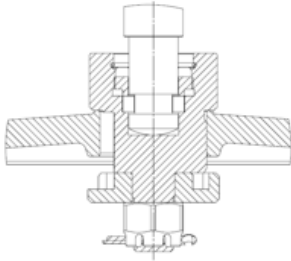

type 00

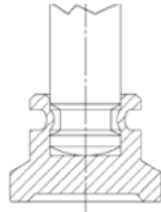

type 41 42 43

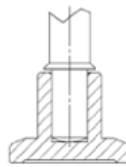

type 31 32 33

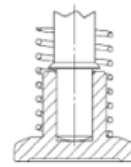

type 71 91



TYPE

Figure	Body material	Nominal diameter	Nominal pressure	Type
216	A Grey cast iron EN-GJL-250	15-50 mm	A 6 bar	00 stem and disc connection - fixed – rolled; stem, disc and seat ring - stainless steel
		15-150 mm	A 6 bar	01 stem and disc connection – nut; stem, disc and seat ring - stainless steel
		200-300 mm	A 6 bar	04 stem and disc connection – nut; stem, disc and seat ring - stainless steel; balancing disc
		15-150 mm	A 6 bar	02 stem and disc connection nut; stem - brass, disc and seat ring - bronze
		200-300 mm	A 6 bar	05 stem and disc connection – nut; stem- brass, disc and seat ring – bronze; balancing disc
		15-150 mm	A 6 bar	03 stem and disc connection nut; stem, disc and seat ring - bronze
		200-300 mm	A 6 bar	13 stem and disc connection – nut; stem, disc and seat ring – bronze; balancing disc
		15-300 mm	A 6 bar	31 loose disc with spring; stem, disc and seat ring - stainless steel
		15-300 mm	A 6 bar	41 loose disc without spring; stem, disc and seat ring - stainless steel
		15-300 mm	A 6 bar	32 loose disc with spring; stem - brass, disc and seat ring - bronze
		15-300 mm	A 6 bar	42 loose disc without spring; stem - brass, disc and seat ring - bronze
		15-300 mm	A 6 bar	33 loose disc with spring; stem, disc and seat ring - bronze
		15-300 mm	A 6 bar	43 loose disc without spring; stem, disc and seat ring - bronze

Data given can be changed without notice.

Edition 01/2018

FIG.216

	15-300 mm	A 6 bar	71 stem and disc connection – nut; stem, throttling disc and seat ring - stainless steel; throttling disc; without position indicator	
	15-300 mm	A 6 bar	91 stem and disc connection – nut; stem, throttling disc and seat ring - stainless steel; throttling disc; with position indicator	
	15-300 mm	A 6 bar	72 stem and disc connection – nut; stem- brass, throttling disc and seat ring – bronze; throttling disc; without position indicator	
	15-300 mm	A 6 bar	92 stem and disc connection – nut; stem - brass, throttling disc and seat ring – bronze; throttling disc; with position indicator	
	15-50 mm	C 16 bar	00 stem and disc connection - fixed – rolled; stem, disc and seat ring - stainless steel	
	15-150 mm	C 16 bar	01 stem and disc connection – nut; stem, disc and seat ring - stainless steel	
	200-300 mm	C 16 bar	04 stem and disc connection – nut; stem, disc and seat ring - stainless steel; balancing disc	
	15-150 mm	C 16 bar	02 stem and disc connection nut; stem - brass, disc and seat ring - bronze	
	200-300 mm	C 16 bar	05 stem and disc connection – nut; stem- brass, disc and seat ring – bronze; balancing disc	
	15-150 mm	C 16 bar	03 stem and disc connection nut; stem, disc and seat ring - bronze	
	200-300 mm	C 16 bar	13 stem and disc connection – nut; stem, disc and seat ring – bronze; balancing disc	
	15-300 mm	C 16 bar	31 loose disc with spring; stem, disc and seat ring - stainless steel	
	15-300 mm	C 16 bar	41 loose disc without spring; stem, disc and seat ring - stainless steel	
	15-300 mm	C 16 bar	32 loose disc with spring; stem - brass, disc and seat ring - bronze	
	15-300 mm	C 16 bar	42 loose disc without spring; stem - brass, disc and seat ring - bronze	
	15-300 mm	C 16 bar	33 loose disc with spring; stem, disc and seat ring - bronze	
	15-300 mm	C 16 bar	43 loose disc without spring; stem, disc and seat ring - bronze	
	15-300 mm	C 16 bar	71 stem and disc connection – nut; stem, throttling disc and seat ring - stainless steel; throttling disc; without position indicator	
	15-300 mm	C 16 bar	91 stem and disc connection – nut; stem, throttling disc and seat ring - stainless steel; throttling disc; with position indicator	
	15-300 mm	C 16 bar	72 stem and disc connection – nut; stem- brass, throttling disc and seat ring – bronze; throttling disc; without position indicator	
	15-300 mm	C 16 bar	92 stem and disc connection – nut; stem - brass, throttling disc and seat ring – bronze; throttling disc; with position indicator	
216	C Nodular cast iron EN-GJS-400-18-LT	15-150 mm	C 16 bar	01 stem and disc connection – nut; stem, disc and seat ring - stainless steel
		200 mm	C 16 bar	04 stem and disc connection – nut; stem, disc and seat ring - stainless steel; balancing disc
		15-150 mm	C 16 bar	02 stem and disc connection nut; stem - brass, disc and seat ring - bronze
		200 mm	C 16 bar	05 stem and disc connection – nut; stem- brass, disc and seat ring – bronze; balancing disc

Data given can be changed without notice.

Edition 01/2018

FIG.216

	15-150 mm	C 16 bar	03 stem and disc connection nut; stem, disc and seat ring - bronze	
	200 mm	C 16 bar	13 stem and disc connection – nut; stem, disc and seat ring – bronze; balancing disc	
	15-200 mm	C 16 bar	31 loose disc with spring; stem, disc and seat ring - stainless steel	
	15-200 mm	C 16 bar	41 loose disc without spring; stem, disc and seat ring - stainless steel	
	15-200 mm	C 16 bar	32 loose disc with spring; stem - brass, disc and seat ring - bronze	
	15-200 mm	C 16 bar	42 loose disc without spring; stem - brass, disc and seat ring - bronze	
	15-200 mm	C 16 bar	33 loose disc with spring; stem, disc and seat ring - bronze	
	15-200 mm	C 16 bar	43 loose disc without spring; stem, disc and seat ring - bronze	
	15-200 mm	C 16 bar	71 stem and disc connection – nut; stem, throttling disc and seat ring - stainless steel; throttling disc; without position indicator	
	15-200 mm	C 16 bar	91 stem and disc connection – nut; stem, throttling disc and seat ring - stainless steel; throttling disc; with position indicator	
	15-200 mm	C 16 bar	72 stem and disc connection – nut; stem- brass, throttling disc and seat ring – bronze; throttling disc; without position indicator	
	15-200 mm	C 16 bar	92 stem and disc connection – nut; stem - brass, throttling disc and seat ring – bronze; throttling disc; with position indicator	
	15-80 mm	D 25 bar	01 stem and disc connection – nut; stem, disc and seat ring - stainless steel	
	15-80 mm	D 25 bar	02 stem and disc connection nut; stem - brass, disc and seat ring - bronze	
	15-80 mm	D 25 bar	03 stem and disc connection nut; stem, disc and seat ring - bronze	
	15-80 mm	D 25 bar	31 loose disc with spring; stem, disc and seat ring - stainless steel	
	15-80 mm	D 25 bar	41 loose disc without spring; stem, disc and seat ring - stainless steel	
	15-80 mm	D 25 bar	32 loose disc with spring; stem - brass, disc and seat ring - bronze	
	15-80 mm	D 25 bar	42 loose disc without spring; stem - brass, disc and seat ring - bronze	
	15-80 mm	D 25 bar	33 loose disc with spring; stem, disc and seat ring - bronze	
	15-80 mm	D 25 bar	43 loose disc without spring; stem, disc and seat ring - bronze	
	15-80 mm	D 25 bar	71 stem and disc connection – nut; stem, throttling disc and seat ring - stainless steel; throttling disc; without position indicator	
	15-80 mm	D 25 bar	91 stem and disc connection – nut; stem, throttling disc and seat ring - stainless steel; throttling disc; with position indicator	
216	E Bronze CuZn5Zn5Pb5-C	15-125 mm	C 16 bar	03 stem and disc connection nut; stem, disc and seat ring - bronze
		150-200 mm	B 10 bar	33 loose disc with spring; stem, disc and seat ring - bronze
		250-300 mm	A 6 bar	43 loose disc without spring; stem, disc and seat ring - bronze
				23 stem and disc connection – nut; with position indicator; stem, disc and seat ring - bronze

Data given can be changed without notice.

Edition 01/2018

FIG.216

				53	loose disc with spring; with position indicator; stem, disc and seat ring - bronze
				63	loose disc without spring; with position indicator; stem, disc and seat ring - bronze
	15-125 mm		C 16 bar	73	stem and disc connection – nut; throttling disc – bronze; without position indicator
	15-125 mm		C 16 bar	93	stem and disc connection – nut; throttling disc - bronze ; with position indicator

ORDERING

Figure	Body material	Nominal diameter	Nominal pressure	Type
216	A Grey cast iron EN-GJL-250	15-50 mm	C 16 bar	00 stem and disc connection - fixed - rolled stem, disc and seat ring - stainless steel

Order example acc. index

216 A 050 C 00

Stop valves, ends flanged, angle form
 Grey cast iron EN-GJL-250
 Nominal diameter (mm)
 Nominal pressure PN 16
 Stem and disc connection - fixed - rolled stem, disc and seat ring - stainless steel

216 A 050 C 00

Data given can be changed without notice.

Edition 01/2018