

 CHECK VALVE zCHE



Body material	Nominal pressure	Nominal diameter	Max. temperature
<b>D</b> Nodular cast iron	<b>C</b> 16 bar	DN <b>50-300</b>	70°C
	<b>B</b> 10 bar	DN <b>350-500</b>	

**FEATURES**

- very slight pressure drop
- fill bore
- self cleaning
- silent
- horizontal and vertical installation

**APPLICATION**

industries



INDUSTRY

media



SEWAGE



INDUSTRIAL  
WATER



NEUTRAL  
FLUIDS

Data given can be changed without notice.

Edition 01/2018

**MATERIALS, DIMENSIONS**

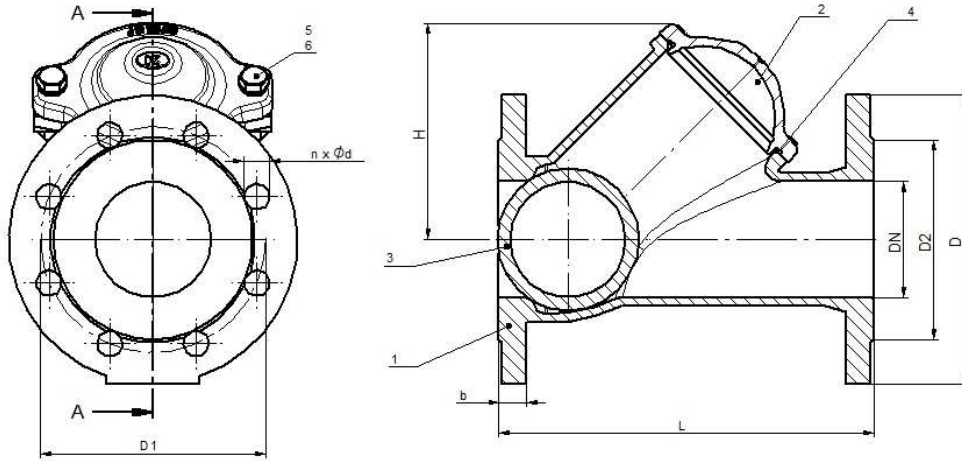

	<b>Body material</b>	<b>D</b>
	<b>Type</b>	<b>55</b>
1	Body	EN- GJS- 500-7 5.3200 (ex.JS 1050)
2	Cover	EN- GJS- 500-7 5.3200 (ex.JS 1050)
3	Ball	Steel/ NBR
4	O - ring	NBR
5	Bolt	AISI 304
6	Nut	AISI 304
<b>Max. temperature</b>		<b>70°C</b>

DN		50	65	80	100	125	150	200	250	300	350	400	500
<b>L (mm)</b>		180	200	240	260	300	350	400	500	600	700	800	1150
<b>D (mm)</b>		165	185	200	220	250	285	340	405	460	520	580	715
EN1092-2- PN10	<b>D1 (mm)</b>	125	145	160	180	210	240	295	350	400	460	515	620
	<b>D2 (mm)</b>	99	118	132	156	184	211	266	319	370	429	480	582
	<b>n-d (mm)</b>	4-19	4-19	8-19	8-19	8-19	8-23	8-23	12-23	12-23	16-23	16-28	20-28
EN1092-2- PN16	<b>D1 (mm)</b>	125	145	160	180	210	240	295	355	410	-----	-----	-----
	<b>D2 (mm)</b>	99	118	132	156	184	211	266	319	370	-----	-----	-----
	<b>n-d (mm)</b>	4-19	4-19	8-19	8-19	8-19	8-23	12-23	12-28	12-28	-----	-----	-----
<b>b (mm)</b>		19	19	19	19	19	19	20	22	24,5	26,6	28	31,5
<b>H (mm)</b>		100	125	136	185	196	265	330	420	480	617	680	1180
<b>K<sub>vs</sub> (m<sup>3</sup>/h)</b>		90	140	253	369	642	962	1990	3100	4100	5050	6500	7800
<b>Weight (kg)</b>		8,5	12	15	22	34	45	80	135	200	300	600	800

Data given can be changed without notice.

Edition 01/2018

ZETKAMA Sp. z o.o.  
Ul. 3 Maja 12  
PL 57-410 Ścinawka Średnia

Tel. +48 74 8652 193  
Tel. +48 74 8652 111  
Fax +48 74 8652 199

E-mail export@zetskama.com.pl  
www.zetskama.com

**PRESSURE-TEMPERATURE RATINGS**

Acc. EN 1092-2	PN		-10°C÷70°C
EN-GJS-500-7	10	bar	10
	16		16

**TYPE**

Figure	Body material	Nominal diameter	Nominal pressure	Type
400	D Nodular cast iron EN-GJS-500-7	50-300 mm	C 16 bar	55 steel NBR coated ball; steel/NBR seat; epoxy paint
		350-500 mm	B 10 bar	55 steel NBR coated ball; steel/NBR seat; epoxy paint

**ORDERING**

Figure	Body material	Nominal diameter	Nominal pressure	Type
400	D Nodular cast iron EN-GJS-500-7	350-500 mm	B 10 bar	55 steel NBR coated ball; steel/NBR seat; epoxy paint

**Order example acc. index**

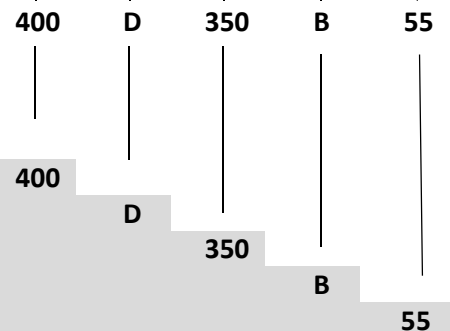

Check valves, ends flanged, form Y-type  
 Nodular cast iron EN-GJS-500-7  
 Nominal diameter (mm)  
 Nominal pressure PN 10  
 Steel NBR coated ball; steel/NBR seat; epoxy paint

Data given can be changed without notice.

Edition 01/2018