

WALWORTH®
Since 1842

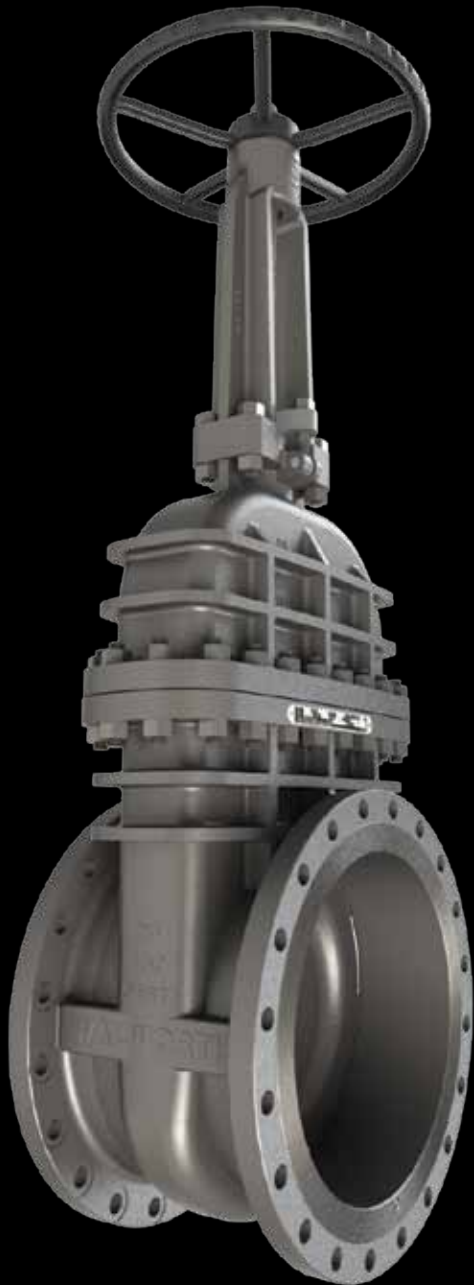

**API-603 CAST STAINLESS STEEL
AND SPECIAL ALLOY VALVE**

CATALOG

INDEX

INTRODUCTION

WALWORTH ENGINEERING CONTROL	5
WALWORTH QUALITY SYSTEM.....	5
QUALITY CONTROL EQUIPMENT.....	9

API-603 CAST STAINLESS STEEL AND SPECIAL ALLOY GATE, GLOBE AND SWING CHECK VALVES

API-603 CAST STAINLESS STEEL & SPECIAL ALLOY VALVES BODY MATERIALS	12
API-603 CAST STAINLESS STEEL & SPECIAL ALLOY VALVES TRIM ARRANGEMENTS	16
COMMON CONSTRUCTION MATERIALS COMBINATION	18
CHEMICAL COMPOSITION AND MECHANICAL PROPERTIES	18
API-603 CAST STAINLESS STEEL & SPECIAL ALLOY GATE VALVES, CLASS 150	19
API-603 CAST STAINLESS STEEL & SPECIAL ALLOY GATE VALVES, CLASS 300	24
API-603 CAST STAINLESS STEEL & SPECIAL ALLOY GATE VALVES, CLASS 600	29
API-603 CAST STAINLESS STEEL & SPECIAL ALLOY GLOBE VALVES, CLASS 150	34
API-603 CAST STAINLESS STEEL & SPECIAL ALLOY GLOBE VALVES, CLASS 300	39
API-603 CAST STAINLESS STEEL & SPECIAL ALLOY GLOBE VALVES, CLASS 600	44
API-603 CAST STAINLESS STEEL & SPECIAL ALLOY SWING CHECK VALVES, CLASS 150	49
API-603 CAST STAINLESS STEEL & SPECIAL ALLOY SWING CHECK VALVES, CLASS 300	52
API-603 CAST STAINLESS STEEL & SPECIAL ALLOY SWING CHECK VALVES, CLASS 600	55
TECHNICAL INFORMATION	58
PRESSURE-TEMPERATURE RATINGS	66
DESIGN BASIS	68
HOW TO ORDER	69
GENERAL TERMS AND CONDITIONS	70



YARMOUTH RESEARCH AND TECHNOLOGY



WALWORTH

WALWORTH is one of the world's most comprehensive industrial valve manufacturers. Founded in 19th century by James Walworth, the Company has consistently dedicated itself to improvements in design and manufacturing of an array of valves exceptionally suited for the world's fluid control sector. We satisfy all end use industries and comprehensive customer requirements by adhering to the most demanding quality standards.

WALWORTH relies on its broad experience in supplying valves to the petrochemical, oil & gas, petroleum, power generation, pulp and paper, cryogenic and geothermal industries, among others.

Over the years, WALWORTH has produced over 40,000 different types of products; by utilizing the expertise of over 500 trained employees, we serve as a global supplier to various markets.

Our manufacturing system includes: utilization of Company directed raw material warehouses; modern and newly acquired specialized machinery; welding processes such as SMAW, GMAW, SAW, PAW; assembly and testing for low pressure, high pressure, and low or high temperatures; painting and coating processes; export crating and shipment.

WALWORTH is capable of providing the world's most comprehensive industrial valve line to the North American, Central American, South American, European and African markets. WALWORTH is proud to meet and satisfy the precise demands of our customers throughout the world by providing quality products, competitive costs and excellent service.



WALWORTH VALUES

MISSION

WALWORTH manufactures and supplies world-class valves and components for the flow control industry through exceptional service, competitive pricing, and consistent on-time deliveries.



VISION

To be the world leader of unparalleled valve manufacturing and supply, WALWORTH:

- Sets the standard for product quality in the flow control industry.
- Exceeds the service expectations of our customers.
- Forges enduring relationships with customers, team members, and community.
- Hires, develops, and retains experienced and dedicated team members.



WALWORTH ENGINEERING CONTROL

WALWORTH products are manufactured strictly following the most recognized international standards in the world, such as API, ANSI, ASME, ASTM, MSS, NACE, BSI and CSA, among others. As a leader in new developments, our Engineering team is constantly studying updates to these standards to incorporate any changes that may affect the design, regulation and/or performance of our products.

Design is produced using the most advanced technology and equipment, finite elements and CAD system programs to ensure proper assembly and performance of products - from concept to calculation to detailed drawings for manufacturing. WALWORTH is a leader in the development of new products according to current valve market needs.

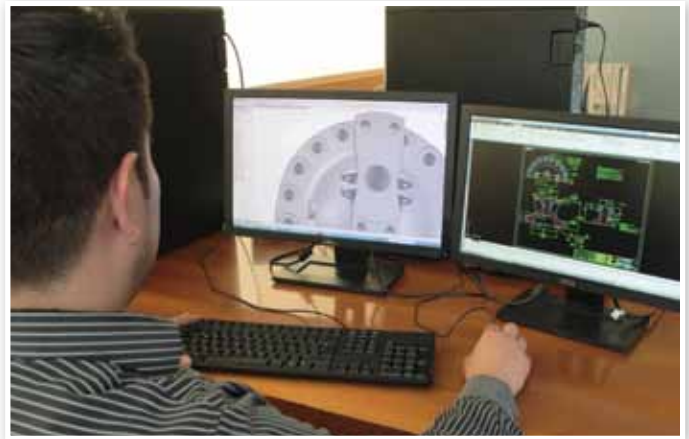

WALWORTH QUALITY SYSTEM

Throughout the years, WALWORTH has developed its Quality System which is an integral part of our manufacturing policy. Our primary goal is to provide products that meet and exceed market standards. In this sense, WALWORTH is an ISO-9001 Audited and Certified Company that has achieved major certifications worldwide. Our system includes the selection of raw materials from approved vendors, and rigorous oversight of our manufacturing process that is vital to quality control. The use of serial numbers allows WALWORTH the ability to not only ensure the quality of components used but to monitor and trace the fabrication process as well.

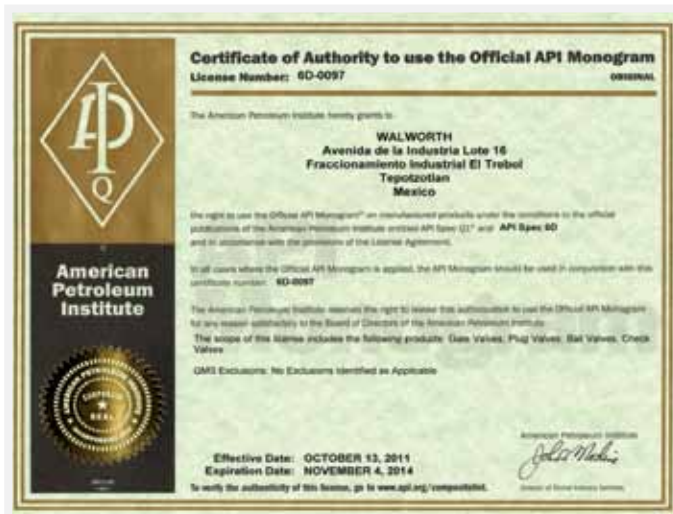

Certificate API-6D No. 6D-0097

Issued by American Petroleum Institute to apply on Gate valves, Plug valves, Ball valves and Check valves manufactured in accordance with API-6D specification.



Certificate API-6A No. 6A-0234

From American Petroleum Institute to apply on valves at PSI, 1 through 4.



Certificate API-594 No. 594-0007
Issued by American Petroleum Institute to apply on Check Valves-Type A; Check Valves Type B manufactured in accordance with API-594 specification.



API-600 Certificate No. 600-0109
Issued by American Petroleum Institute to apply on Bolted Bonnet Steel Gate Valves manufactured in accordance with API-600 specification.



API-602 Certificate No. 602-0024
Issued by American Petroleum Institute to apply on Compact Steel Gate Valves, Compact Steel Globe Valves, and Compact Steel Check Valves manufactured in accordance with API-602 specification.



Certificate ISO-9001 No. 0038
Issued by American Petroleum Institute since April 1999.



Certificate as per PED 97/23/EC Module H
To stamp CE products.



Supplier Qualification Certificate NO. 279/13
Issued by the Equipment and Materials Testing Laboratory, CFE (LAPEM in Spanish)



Certificate NMX-CC-9001 (Mexican Standards ISO-9001) No. 0552/2007 Issued by PEMEX in accordance with ISO-9001 Quality Assurance System.

PRODUCT CERTIFICATIONS



Emissions after 500 cycles at ambient and 350 °F
Issued by Yarmouth Research and Technology Lab for 3 inch Class 300 Gate Valve After 500 cycles the measurement result was less than 50 ppm.



Emissions after 500 cycles at ambient and 350 °F
Issued by Yarmouth Research and Technology Lab for 8 inch Class 300 Gate Valve After 500 cycles the measurement result was less than 50 ppm.



Emissions after 500 cycles at ambient and 350 °F
Issued by Yarmouth Research and Technology Lab for 16 inch Class 150 Gate Valve After 500 cycles the measurement result was less than 50 ppm.





Certificates of Ultra Low Fugitive Emissions No. 20985-3, 8 & 16 in accordance with ISO-15848-1 "Industrial Valves" Measurement, Test and Qualification Procedures for Fugitive Emissions "Part 1: Classification System and Qualification Procedures for Type Testing of Valves".

TÜV Rheinland Certificate No. TRASA 700-13-0019
API-6D Trunnion mounted bolted body ball valves, carbon steel (A105-WCB) construction, double block and bleed service, primarily used but not limited to the oil and gas standard and severe applications.

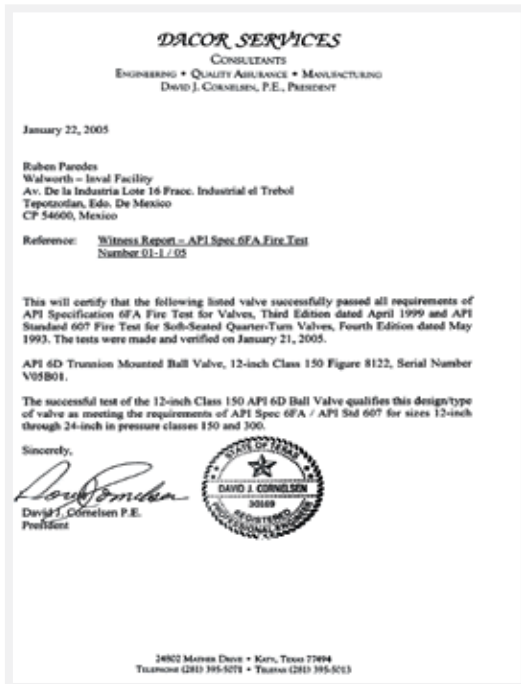

Fire Test Certificate No. 01-1/05
In accordance with API-6FA and API Standard API-607 for Trunnion Ball Valves in accordance with API-6D.

TA Luft Certificate (Fugitive Emission) Approval
ISO-5211 Top Flange, Anti-Static Device.

QUALITY CONTROL EQUIPMENT

In order to assure that **WALWORTH** products comply with international quality standards, in-house equipment is used for quality control, some of this equipment includes:

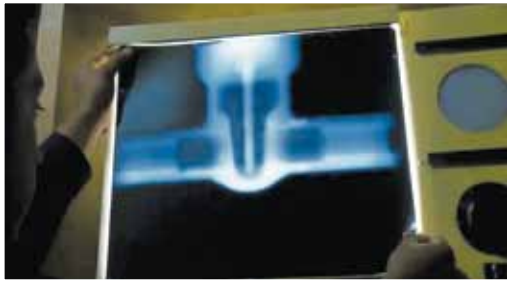

X-Ray Examination Equipment.- WALWORTH has its own Ir-92 source in-house for the radiographic examination (RT) of castings from 0.100" up to 2 1/2" wall thickness to verify the soundness of the raw casting material.

PMI Equipment.- New generation of Positive Material Identification Equipment gives WALWORTH the capability to perform quick chemical analysis on incoming raw materials and on pieces after assembly to certify that materials used were produced and assembled in accordance with WALWORTH and the Customer's specifications.



Magnetic Particle Test.- On a random basis for standard products or when a Customer requests MT Certification, WALWORTH uses Magnetic Particle Testing Equipment on ferromagnetic materials.

Penetrant Test Examination.- WALWORTH has the personnel and materials to perform PT examination by solvent removable or water washable techniques. The NDT personnel are ASNT Certified.



Test Loop. A complete Laboratory Test loop exists for design validation of WALWORTH products, performing the test at maximum design pressure and cycling the valves from 3000 to 5000 cycles. The test takes more than four months to be completed.

Pressure Gradient Test Loop.- This test exposes Plug valves to the extremes of both positive and negative pressure gradients to verify that the plug in a balanced plug design will prevent lock-up in the body.





Metrology Laboratory.- WALWORTH developed a calibration and/or verification system in all the equipment used in its facilities to ensure the traceability of measurements to international standards. In this way, WALWORTH gets measurement control of its products to comply with international standards.

Fire Test Facilities.- Facilities to perform fire test in accordance to API requirements. The test exposes the valve to a flame at 1400 to 1800°F (761 to 980°C) to verify proper sealing of the valve.



Low Fugitive Emissions Test.- When a Customer requires low fugitive emissions certification, the Lab has its own LFE Test Equipment capable of measuring less than 20 ppm in either static or mechanical conditions at ambient temperature or thermal cycle operations.

Ultrasonic Testing Equipment.- Using ultrasonic techniques, WALWORTH can detect sub-surface flaws in materials and evaluate castings and forgings that cannot be radiographed. In addition, WALWORTH utilizes these techniques to measure the wall thickness of castings and forgings.



Tensile Test Equipment.- To verify the mechanical properties of materials used for manufacturing, WALWORTH tests samples on a random basis even though we receive MTR's from our suppliers and foundries.

Hardness Test Equipment.- In either lab or shop tests, WALWORTH uses hardness testing equipment such as Rockwell B, C Brinell or Vickers to check compliance against specifications.



API-603 CAST STAINLESS STEEL & SPECIAL ALLOY GATE, GLOBE AND CHECK VALVES

API-603 CAST STAINLESS STEEL & SPECIAL ALLOY GATE, GLOBE AND CHECK VALVES STAINLESS STEEL, SPECIAL ALLOY & EXOTIC ALLOY VALVES

The light pattern WALWORTH product line, manufactured in accordance with ANSI classes 150, 300 & 600# and sizes from 2” up to 24” nominal diameter, provides the end user a wide variety of valves to satisfy their needs. This product line is manufactured as per API-603 design requirements for gate, globe & swing check valves.

One of the most important features of WALWORTH API-603 Cast Stainless Steel Valves is that they guarantee a 50 ppm maximum fugitive emissions rate as furnished “off the shelf” without a Customer’s special order requirements.

WALWORTH offers the majority of materials known and used for this product line, including but not limited to:

1. Stainless Steel such as CF8, CF8M, CF8C, CF10, CG8M, etc.
2. Low Carbon Stainless Steel such as CF3, CF3M, CG3M, etc.
3. Super Stainless Steel such as CN7M(Alloy 20), CN3M (Alloy 20 modified), CT15C, etc.
4. Duplex Stainless Steel such as CE8MN, CD6MN, CD3MN, etc.
5. High Nickel Alloys such as Monel M30C, Monel M35-1, Monel CZ100, Inconel CY40 (Inconel 600), CW2M (Hastelloy C4), N12MV (Hastelloy B), CW12MW (Former Hastelloy C-276), CW6M (New Hastelloy C-276), CU5MCuC (Incoloy 825), N7M (Hastelloy B2), CW6MC (Incoloy 625), etc.
6. Super Duplex Stainless Steel such as CE3MN, CD3MNCuN, etc.

Type	Size	Pressure class as per ASME B16.34	Ends
Gate	2” to 24”	150, 300 & 600	RF, RTJ & WE
Globe	2” to 24”	150, 300 & 600	RF, RTJ & WE
Swing Check	2” to 24”	150, 300 & 600	RF, RTJ & WE



API-603 CAST STAINLESS STEEL & SPECIAL ALLOY VALVES BODY MATERIALS

WALWORTH offers the standard product line of API 603 Cast Steel valves in a wide variety of stainless steel, high nickel alloys and exotic alloys that can be used in combination with either their specific trims or one requested by the Customer.

Material suffix	Common designation	Forging specification	Wrought bar specification	Service recommendations (1)	Common trim for this base material
ASTM A351 Grade CF8	18% Chrome; 8% Nickel; 0.08% C Stainless Steel	ASTM A182 F304	ASTM A479 304	Corrosive or extremely high temperature non-corrosive services between -450°F (-268°C) and +1200°F (+649°C). Above +800°F (+425°C) specify carbon content of 0.04% or greater.	2, 4HF
ASTM A351 Grade CF8M	18% Chrome; 12% Nickel; 2% Mo; 0.08% C Stainless Steel	ASTM A182 F316	ASTM A479 316	Corrosive or either extremely low or high temperature non-corrosive services between -450°F (-268°C) and +1200°F (+649°C). Above +800°F (+425°C) specify carbon content of 0.04% or greater.	18-8smo, 3HF
ASTM A351 Grade CF3	18% Chrome; 8% Nickel; 0.03% C Low Carbon Stainless Steel	ASTM A182 304L	ASTM A479 304L	Brackish water, phosphate solutions, pressurized water @ 570°F (299°C), sea water, steam.	304L, 3HF
ASTM A351 Grade CF3M	18% Chrome; 12% Nickel; 2% Mo; 0.03% C Low Carbon Stainless Steel	ASTM A182 F316L	ASTM A479 316L	Acetic acid, calcium carbonate, calcium lactate, potable water, sea water, steam, sulfites.	316L, 3HF
ASTM A351 Grade CG3M	18% Chrome; 12% Nickel; 3% Mo; 0.03% C Low Carbon Stainless Steel	ASTM A182 F317L	ASTM A182 F317L	Corrosive or non corrosive services to +800°F (+425°C)"	317L, 317LH
ASTM A351 Grade CF8C	18% Chrome; 10% Nickel; Cb; 0.08% C Stainless Steel	ASTM A182 F347	ASTM A479 347	Primarily for high temperature, corrosive applications between -450°F (-268°C) and +1200°F (+649°C). Above +1000°F (+540°C) specify carbon content of 0.04% or greater. Hydrogen service."	347H, 347HF
ASTM A351 Grade CF10	18% Chrome; 8% Nickel; 0.08% C Stainless Steel	ASTM A182 F304H	ASTM A479 304H	Corrosive or extremely high temperature non-corrosive services between -450°F (-268°C) and +1200°F (+649°C). Above +800°F (+425°C) specify carbon content of 0.04% or greater.	310, 310HF
ASTM A351 Grade CF10M	18% Chrome; 8% Nickel; 2% Mo; 0.08% C Stainless Steel	ASTM A182 F316H	ASTM A479 316H	Corrosive or extremely high temperature non-corrosive services between -450°F (-268°C) and +1200°F (+649°C). Above +800°F (+425°C) specify carbon content of 0.04% or greater.	310, 310HF
ASTM A351 Grade CG8M	18% Chrome; 10% Nickel; 3% Mo; 0.08% C Stainless Steel	ASTM A182 F317	ASTM A182 F317	Heavy water manufacturing, nuclear, petroleum, pipe line, power, pulp and paper, printing textile, corrosive dye solutions, ink, sulfite liquor.	317H, 21HF

API-603 CAST STAINLESS STEEL & SPECIAL ALLOY VALVES BODY MATERIALS

Material suffix	Common designation	Forging specification	Wrought bar specification	Service recommendations (1)	Common trim for this base material
ASTM A351 Grade CK20	25% Chrome; 20% Nickel; 0.04 To 0.2% C Super Stainless Steel	ASTM A182 F310H	ASTM A182 F310H	Aircraft, chemical processing, oil refining, pulp and paper. Corrosives hot products around 1200°F (649°C), sulfite liquor, sulfuric acid (dilute).	310, 310HF
ASTM A351 Grade CN7M	19% Chrome; 28% Nickel; Cu-Mo; 0.07 % C Super Stainless Steel	ASTM B462 N08020	ASTM B473 N08020	Acetic acid (hot), brines, caustic solutions, (strong, hot), hydrochloric acid (dilute), hydrofluoric acid and hydrofluosilicic acid (dilute), nitric acid, (strong, hot), nitric-hydrofluoric pickling acids, sulfates and sulfites, sulfuric acid, (all concentrations to 150°F (65.6°C), sulfurous acid, phosphoric acid.	A20, A20H
ASTM A351 Grade CN3MN	19% Chrome; 28% Nickel; Cu-Mo; 0.03 % C Super Stainless Steel	ASTM B462 N08020	ASTM B473 N08020	Acetic acid (hot), brines, caustic solutions, (strong, hot), hydrochloric acid (dilute), hydrofluoric acid and hydrofluosilicic acid (dilute), nitric acid, (strong, hot), nitric-hydrofluoric pickling acids, sulfates and sulfites, sulfuric acid, (all concentrations to 150°F (65.6°C), sulfurous acid, phosphoric acid. Better weldability properties than CN7M	A20, A20H
ASTM A351 Grade CK3MCuN	20% Chrome; 18% Nickel; 6% Mo; 0.25% C Super Stainless Steel	ASTM A182 F44	ASTM A479 S31254	Acetic acid, antibiotics and drugs, bleaching compounds, formic acid, fruit and juices, hot air, hot water, hydrocarbons, hydrochloric acid, organic liquids and acids, nitric acid, organic salts, oxalic acid, phosphoric acid, sea water, sewage, sodium bisulfite, steam, sulfamic acid, 10% sulfuric acid,	254HF
ASTM A351 Grade CT15C	19% Chrome; 32% Nickel; 0.05 to 0.15% C Incoloy 800.	ASTM B564 N08810	ASTM B408 N08810		810T
ASTM A351 Grade CK3McuN	20% Chrome; 18% Nickel; 6.5% Mo; 0.025% C Super Stainless Steel	ASTM A182 F44	ASTM A479 S31254	High resistance to pitting and crevice corrosion. Very high resistance to chloride stress corrosion cracking. 50% stronger than 300 series austenitic stainless steels. Excellent impact resistance.	31254H
ASTM A351 Grade CN2MCuN	21% Chrome; 25.5% Nickel; 4.5% Mo; 1.5%Cu; 0.02% C Super Stainless Steel	ASTM B469 8904	ASTM B625 8904	Chloride-containing environments where conventional 300 series stainless steel does not provide adequate pitting and crevice corrosion resistance.	8904H
ASTM A494 Grade M-35-1	67% Ni; 30% Cu, Monel	ASTM B564 N04400	ASTM B164 N04400	Weldable grade. Good resistance to corrosion by all common organic acids and salt water. Also highly resistant to most alkaline solutions to +750 °F (+400°C)	A, AHF
ASTM A494 Grade CZ100	95% Nickel	ASTM B160 N02200	ASTM B160 N02200	Chemical processing, mineral processing, food processing. Nickel is useful in handling hot concentrate alkaline or caustic solutions, reducing acids, certain food products, organic acids under certain conditions, dry chlorine and anhydrous ammonia. Cast nickel is not applicable in oxidizing acids and alkaline perchlorite.	2200

API-603 CAST STAINLESS STEEL & SPECIAL ALLOY VALVES BODY MATERIALS

Material suffix	Common designation	Forging specification	Wrought bar specification	Service recommendations (1)	Common trim for this base material
ASTM A494 Grade CY-40	75% Nickel; 15% Cr; 8% Fe, Inconel 600	ASTM B564 N06600	ASTM B166 N06600	Very good for high temperature service. Good resistance to strongly corrosive media and atmosphere to +800°F (+425°C). Hot boiler feed water, hot caustics, hot concentrate alk water, elevated temperature oxidizing conditions.	600, 600HF
ASTM A494 Grade CW6MC	60% Nickel; 22% Cr; 9% Mo; 3.5% Cb, Inconel 625	ASTM B564 N06625	ASTM B446 N06625	Very good for high temperature service. Good resistance to strongly corrosive media and atmosphere to +800°F (+425°C).	625, 625HF
ASTM A494 Grade CU5MCuC	42% Nickel; 21.5% Cr; 3% Mo; 2.3% Cu, Incoloy 825	ASTM B564 N08825	ASTM B425 N08825	Sour gas service. Excellent resistance to both reducing and oxidizing acids, stress corrosion cracking, localized attack such as pitting and crevice corrosion, and sulfuric and phosphoric acids.	825, 23HF
ASTM A494 Grade N12MV	62% Nickel; 28% Mo; 5% Fe, Hastelloy B	ASTM B335 N10001	ASTM B335 N10001	Excellent corrosion resistance. Suitable for most chemical process applications. Excellent resistance to pitting and stress corrosion cracking.	10001, HB
ASTM A494 Grade N7M	62% Nickel; 28% Mo; 2% Fe, Hastelloy B2	ASTM B335 N10665	ASTM B335 N10665	Excellent corrosion resistance and improved resistance to knife-line and heat affected zone attack. Resists formation of grain-boundary carbide precipitates in the weld heat-affected zone.	HB
ASTM A494 Grade CW2M	61% Nickel; 16% Mo; 16% Cr, Hastelloy C4	ASTM B574 N06455	ASTM B574 N06455	Good resistance to strong oxidation conditions. Good properties at high temperatures, high resistance to formic, phosphoric, sulphurous and sulfuric acids to +1200°F (+649°C)	6455H
ASTM A494 Grade CW12MW	56% Nickel; 18% Mo; 17% Cr; 6% Fe, Hastelloy C-276 (FORMER ALLOY)	ASTM B574 N10276	ASTM B574 N10276	Good resistance to strong oxidation conditions. Good properties at high temperatures, high resistance to formic, phosphoric, sulphurous and sulfuric acids to +1200°F (+649°C)	HC, HCH
ASTM A494 Grade CW6M	56% Nickel; 19% Mo; 18% Cr; 16% Fe, Hastelloy C-276 (NEW ALLOY)	ASTM B574 N10276	ASTM B574 N10276	Good resistance to strong oxidation conditions. Good properties at high temperatures, high resistance to formic, phosphoric, sulphurous and sulfuric acids to +1200°F (+649°C)	HC, HCH
ASTM A995 Grade CD4MCuN	25.5% Chrome; 5.5% Nickel; 2% Mo; 0.040% C Duplex Stainless Steel Grade 1A.	N/A	ASTM A479 S32550	Concentrated brine, fatty acids, potable water, pulp water, pulp liquors at 220°F (104°C), sea water, stem, sulfuric acid (15-30% @ 140-160°F (60-71°C), sulfuric acid (35-40% @ 185°F (85°C), plus 5% organics).	32250H
ASTM A995 Grade CE8MN	24% Chrome; 9.5% Nickel; 4% Mo; 0.080% C Duplex Stainless Steel Grade 2A.	ASTM A182 F51	ASTM A479 32750	Concentrated brine, fatty acids, potable water, pulp water, pulp liquors at 220°F (104°C), sea water, stem, sulfuric acid (15-30% @ 140-160°F (60-71°C), sulfuric acid (35-40% @ 185°F (85°C), plus 5% organics).	32750H, 31803H, 51H

API-603 CAST STAINLESS STEEL & SPECIAL ALLOY VALVES BODY MATERIALS

Material suffix	Common designation	Forging specification	Wrought bar specification	Service recommendations (1)	Common trim for this base material
ASTM A995 Grade CD3MN	22% Chrome; 5% Nickel; 3% Mo; N; 0.030% C Duplex Stainless Steel Grade 4A.	ASTM A182 F51	ASTM A479 31803	Concentrated brine, fatty acids, potable water, pulp water, pulp liquors at 220°F (104°C), sea water, stem, sulfuric acid (15-30% @ 140-160°F (60-71°C), sulfuric acid (35-40% @ 185°F (85°C), plus 5% organics).	32750H, 31803H, 51H
ASTM A995 Grade CE3MN	25% Chrome; 7% Nickel; 4.5% Mo; N; 0.030% C Duplex Stainless Steel Grade 5A.	ASTM A182 F53	ASTM A182 F53	Concentrated brine, fatty acids, potable water, pulp water, pulp liquors at 220°F (104°C), sea water, stem, sulfuric acid (15-30% @ 140-160°F (60-71°C), sulfuric acid (35-40% @ 185°F (85°C), plus 5% organics). Useful where the Pitting Resistance Number (PREN) is required.	53H, 53HF
ASTM A995 Grade CD3MWCuN	25% Chrome; 7.5% Nickel; 3.5% Mo; N; 0.030% C Duplex Stainless Steel Grade 6A.	ASTM A182 F53	ASTM A182 F53	Concentrated brine, fatty acids, potable water, pulp water, pulp liquors at 220°F (104°C), sea water, stem, sulfuric acid (15-30% @ 140-160°F (60-71°C), sulfuric acid (35-40% @ 185°F (85°C), plus 5% organics). Useful where the Pitting Resistance Number (PREN) is required.	53H, 53HF

(1) The above list of consuming industries and corrosive materials are useful as examples of typical applications where these materials can be used as a guide; however, the responsibility to choose the proper alloy lies with the Engineering firm or End User.

NOMENCLATURE

Type	Class
ST6	STELLITE 6
316	STAINLESS STEEL 316
304	STAINLESS STEEL 304
HC	HASTELLOY "C"
CN7M	CHROME-NICKEL STEEL
321	STAINLESS STEEL 321
ST21	STELLITE 21
A20	STAINLESS STEEL ALLOY 20
347	STAINLESS STEEL 347
321	STAINLESS STEEL 321
8810	STAINLESS STEEL 8810
625	INCONEL 625
316L	STAINLESS STEEL 316L

Type	Class
HB	HASTELLOY "B"
317L	STAINLESS STEEL 317L
17 4PH	STAINLESS STEEL 17 4PH
317	STAINLESS STEEL 317
825	INCOLOY 825
304L	STAINLESS STEEL 304L
K500	MONEL K500
31803	STAINLESS STEEL 31803
718	INCONEL 718
8367	STAINLESS STEEL 8367
TC	TUNGSTEN CARBIDE
W1	WALWELD-100
NUC	NUCALLOY

API-603 CAST STAINLESS STEEL & SPECIAL ALLOY VALVES TRIM ARRANGEMENTS

WALWORTH valves are available in the widest range of standard and special trims available in the Industry. The following table shows the most popular trims used for the valves currently offered.

Special trims as per Customer requirements are available upon request. Please contact your closest WALWORTH Distributor.

WALWORTH Trim Nr.	API-600 Trim Nr.	Seal material Type	Stem and other Trim parts (1)	Wedge/disc seat Surfaces	Body seat Surfaces (2)
18-8	2	19Cr-9.5Ni-2Mn-0.08C	SS-304	SS-304	SS-304
310	3	25Cr-20.5Ni-2Mn	SS-310	SS-310	SS-310
A	9	70Ni-30Cu	UN N04400 (Monel 400)	UN N04400 (Monel 400)	UN N04400 (Monel 400)
18-8smo	10	18Cr-12Ni-2.5Mo-2Mn	SS-316	SS-316	SS-316
AHF	11 OR 11A	70Ni-30Cu/1/2Co-Cr-A	UN N04400 (Monel 400)	UN N04400 (Monel 400)	Stellite 6 (350 HBN min)
3HF	12 OR 12A	18Cr-12Ni-2.5Mo-2Mn/1/2Co-Cr-A	SS-316	SS-316	Stellite 6 (350 HBN min)
A20	13	29Ni-19Cr-2.5Mo-0.07C	UNS N08020 (Alloy 20)	UNS N08020 (Alloy 20)	UNS N08020 (Alloy 20)
A20H	14 OR 14A	29Ni-19Cr-2.5Mo-0.07C/1/2Co-Cr-A	UNS N08020 (Alloy 20)	UNS N08020 (Alloy 20)	Stellite 6 (350 HBN min)
4HF	Not specified	19Cr-9.5Ni-2Mn-0.08C/1/2Co-Cr-A	SS-304	SS-304	Stellite 6 (350 HBN min)
4HF+HF	Not specified	19Cr-9.5Ni-2Mn-0.08C/Co-Cr-A	SS-304	Stellite 6 (350 HBN min)	Stellite 6 (350 HBN min)
304L	Not specified	19Cr-9.5Ni-2Mn-0.03C	SS-304L	SS-304L	SS-304L
1HF	Not specified	18Cr-12Ni-2.5Mo-2Mn/Co-Cr-Mo	SS-316	Stellite 21 (320 HBN min)	Stellite 21 (320 HBN min)
3HF+HF	16	18Cr-12Ni-2.5Mo-2Mn/Co-Cr-A	SS-316	Stellite 6 (350 HBN min)	Stellite 6 (350 HBN min)
3TC (3)	Not specified	18Cr-8Ni-Mo/TgC	SS-316/Tungsten carbide	Tungsten Carbide	Stellite 6 (350 HBN min)
316L	Not specified	17Cr-12Ni-2.5Mo-2Mn0.03C	SS-316L	SS-316L	SS-316L
3LHF	Not specified	17Cr-12Ni-2.5Mo-2Mn0.03C/1/2Co-Cr-A	SS-316L	SS-316L	Stellite 6 (350 HBN min)
3HFL	Not specified	17Cr-12Ni-2.5Mo-2Mn0.03C/Co-Cr-A	SS-316L	Stellite 6 (350 HBN min)	Stellite 6 (350 HBN min)
21HF	Not specified	19Cr-11.5Ni-3.5Mo/Co-Cr-A	SS-317	Stellite 6 (350 HBN min)	Stellite 6 (350 HBN min)
317	Not specified	19Cr-11.5Ni-3.5Mo	SS-317	SS-317	SS-317
21HF	Not specified	19Cr-11.5Ni-3.5Mo/Co-Cr-A	SS-317	Stellite 6 (350 HBN min)	Stellite 6 (350 HBN min)
317	Not specified	19Cr-11.5Ni-3.5Mo	SS-317	SS-317	SS-317
3LHF	Not specified	17Cr-12Ni-2.5Mo-2Mn0.03C/1/2Co-Cr-A	SS-316L	SS-316L	Stellite 6 (350 HBN min)
3HFL	Not specified	17Cr-12Ni-2.5Mo-2Mn0.03C/Co-Cr-A	SS-316L	Stellite 6 (350 HBN min)	Stellite 6 (350 HBN min)
21HF	Not specified	19Cr-11.5Ni-3.5Mo/Co-Cr-A	SS-317	Stellite 6 (350 HBN min)	Stellite 6 (350 HBN min)
317	Not specified	19Cr-11.5Ni-3.5Mo	SS-317	SS-317	SS-317

Notes: 1. Free machining grades of 13 Cr are prohibited.
 2. A minimum of 50 HB against seat ring(s) is required.

API-603 CAST STAINLESS STEEL & SPECIAL ALLOY VALVES TRIM ARRANGEMENTS

WALWORTH Trim Nr.	API-600 Trim Nr.	Seal material Type	Stem and other Trim parts (1)	Wedge/disc seat Surfaces	Body seat Surfaces (2)
317H	Not specified	19Cr-11.5Ni-3.5Mo/1/2Co-Cr-A	SS-317	SS-317	Stellite 6 (350 HBN min)
317LH	Not specified	19Cr-13Ni-3.5Mo/Co-Cr-A	SS-317L	Stellite 6 (350 HBN min)	Stellite 6 (350 HBN min)
317L	Not specified	19Cr-13Ni-3.5Mo-0.03C	SS-317L	SS-317L	SS-317L
317LS	Not specified	19Cr-13Ni-3.5Mo/1/2Co-Cr-A	SS-317L	SS-317L	Stellite 6 (350 HBN min)
2HF	Not specified	18Cr-10Ni-0.1N/Co-Cr-A	SS-321	SS-321	Stellite 6 (350 HBN min)
321F	Not specified	18.5Cr-11Ni-2Mn/Co-Cr-A	SS-321	Stellite 6 (350 HBN min)	Stellite 6 (350 HBN min)
321	Not specified	19Cr-11.5Ni-3.5Mo	SS-321	SS-321	SS-321
347HF	Not specified	18.5Cr-11Ni-2Mn-Co/Co-Cr-A	SS-347	Stellite 6 (350 HBN min)	Stellite 6 (350 HBN min)
347	Not specified	18.5Cr-11Ni-2Mn-Co	SS-347	SS-347	SS-347
347H	Not specified	18.5Cr-11Ni-2Mn-Co/1/2Co-Cr-A	SS-347	SS-347	Stellite 6 (350 HBN min)
254HF	Not specified	20Cr-18Ni-6.2Mo-0.02C-Cu+N	UNS S31254	Stellite 6 (350 HBN min)	Stellite 6 (350 HBN min)
51H	Not specified	22Cr-5.5Ni-3Mo-N-0.03C/Co-Cr-A	UNS S31803	Stellite 6 (350 HBN min)	Stellite 6 (350 HBN min)
31803H	Not specified	22Cr-5.5Ni-3Mo-N-0.03C/Co-Cr-A	UNS S31803	UNS S31803	Stellite 6 (350 HBN min)
T9	Not specified	16Cr-4Ni-4Cu-Nb+Ta/Co-Cr	17-4pH	Triballoy 900	Triballoy 900
HC	Not specified	55Ni-15.5Cr-16Mo-3Tg-4Fe	Hastelloy C-276	Hastelloy C-276	Hastelloy C-276
HCH	Not specified	55Ni-15.5Cr-16Mo-3Tg-4Fe/1/2Co-Cr-A	Hastelloy C-276	Hastelloy C-276	Stellite 6 (350 HBN min)
UOP	Not specified	63Ni-30Cu-Al+Ti/70Ni-30Cu	UN N05500 (Monel K-500)	UN N04400 (Monel 400)	UN N04400 (Monel 400)
625	Not specified	60Ni-22Cr-9Mo-3.5Cb	UNS N06625 (Inconel 625)	UNS N06625 (Inconel 625)	UNS N06625 (Inconel 625)
625HF	Not specified	60Ni-22Cr-9Mo-3.5Cb/Co-Cr-A	UNS N06625 (Inconel 625)	Stellite 6 (350 HBN min)	Stellite 6 (350 HBN min)
8367HF+HF	Not specified	25Ni-20Cr-6.5Mo-2Mn-0.03C/Co-Cr-A	UNS N08367 (AL6XN)	Stellite 6 (350 HBN min)	Stellite 6 (350 HBN min)
810T	Not specified	33Ni-21Cr-39.5Fe-1.5Mn	UNS N08810 (Incoloy 800H)	UNS N08810 (Incoloy 800H)	UNS N08810 (Incoloy 800H)
825	Not specified	42Ni-21.5Cr-3Mo-Ti+Al-0.05C	UNS N08825 (Incoloy 825)	UNS N08825 (Incoloy 825)	UNS N08825 (Incoloy 825)
23HF	Not specified	42Ni-21.5Cr-3Mo/CO-Cr-Mo	UNS N08825 (Incoloy 825)	Stellite 21 (320 HBN min)	Stellite 21 (320 HBN min)
HB	Not specified	66Ni-28Mo-1Mn-0.02C	UNS N10665 (Hastelloy B2)	UNS N10665 (Hastelloy B2)	UNS N10665 (Hastelloy B2)

Notes: 1. A minimum of 50 HB against seat ring(s) is required.

COMMON CONSTRUCTION MATERIALS COMBINATION

The following table shows the most common combination of base materials and trim. There are many other trims which can be combined with these base materials. Please refer to other sections of this catalog for additional information.

GATE VALVES 150#						
Description	ASTM A351 CF8M Trim 3HF (API-600 nr. 12)	ASTM A351 CF8C Trim 347H (API-600 nr. N/A)	ASTM A351 CN7M Trim A20H (API-600 nr. 14)	ASTM A494 M35-1 Trim AHF (API-600 nr. 11)	ASTM A494 CW12MW Trim HCH (API-600 N/A)	ASTM A995 CD3MN Trim 31803H (API-600 nr. N/A)
Body	ASTM A351 CF8M	ASTM A351 CF8C	ASTM A351 CN7M	ASTM A494 M35-1	ASTM A494 CW12MW	ASTM A995 CD3MN
Bonnet	ASTM A351 CF8M	ASTM A351 CF8C	ASTM A351 CN7M	ASTM A494 M35-1	ASTM A494 CW12MW	ASTM A995 CD3MN
Wedge/seating	ASTM A351 CF8M, Stellite 6	ASTM A351 CF8C, Stellite 6	ASTM A351 CN7M, Stellite 6	ASTM A494 M35-1, Stellite 6	ASTM A494 CW12MW, Stellite 6	ASTM A995 CD3MN, Stellite 6
Seat rings	ASTM A351 CF8M	ASTM A351 CF8C	ASTM A351 CN7M	ASTM A494 M35-1	ASTM A494 CW12MW	ASTM A995 CD3MN
Stem nut	ASTM B 148 UNS C95600	ASTM B 148 UNS C95600	ASTM B 148 UNS C95600	ASTM B 148 UNS C95600	ASTM B 148 UNS C95600	ASTM B 148 UNS C95600
Bonnet bushing	SS-304	SS-410	ASTM A 276 Type 316	ASTM A 276 Type 316	ASTM A 276 Type 316	ASTM A 276 Type 316
Bonnet stud	ASTM A193 Gr. B8	ASTM A193 Gr. B8	ASTM A193 Gr. B8	ASTM A193 Gr. B8	ASTM A193 Gr. B8	ASTM A193 Gr. B8
Bonnet stud nut	ASTM A194 Gr. 8	ASTM A194 Gr. 8	ASTM A194 Gr. 8	ASTM A194 Gr. 8	ASTM A194 Gr. 8	ASTM A194 Gr. 8
Stem packing	Flexible graphite intermediate rings / Anti-extrusion rings on the top and bottom sides of the packing chamber	Flexible graphite intermediate rings / Anti-extrusion rings on the top and bottom sides of the packing chamber	Flexible graphite intermediate rings / Anti-extrusion rings on the top and bottom sides of the packing chamber	Flexible graphite intermediate rings / Anti-extrusion rings on the top and bottom sides of the packing chamber	Flexible graphite intermediate rings / Anti-extrusion rings on the top and bottom sides of the packing chamber	Flexible graphite intermediate rings / Anti-extrusion rings on the top and bottom sides of the packing chamber
Bonnet gasket	Graphite/316 Stainless	Graphite/316 Stainless	Graphite/316 Stainless	Graphite/316 Stainless	Graphite/316 Stainless	Graphite/316 Stainless
Handwheel	As per WALWORTH design	As per WALWORTH design	As per WALWORTH design	As per WALWORTH design	As per WALWORTH design	As per WALWORTH design
Gear operator	Commercial	Commercial	Commercial	Commercial	Commercial	Commercial

CHEMICAL COMPOSITION AND MECHANICAL PROPERTIES

The following table shows the nominal chemical composition and mechanical properties for the most common materials supplied. Additional information can be requested from your closest WALWORTH Distributor for other steels, stainless steels or Nickel alloys.

Chemical composition and mechanical properties											
Elements and properties	Stainless steel		Low carbon stainless steel		Nickel alloy steel		Nickel alloy steel		Duplex stainless steel		
	ASTM A 351		ASTM A 351		ASTM A 494				ASTM A995		
	CF8M	CF8	CG3M	CF3	M35-1(B)	CW12MW	CW6MC	CU5MCuC	CD4MCuN	CD3MN	CE3MN
Carbon	0.08	0.08	0.03	0.03	0.35	.012	0.06	0.050	0.040	0.030	0.030
Manganese	1.50	1.50	1.50	1.50	1.50	1.00	1.00	1.0	1.00	1.50	1.50
Phosphorus	0.04	0.04	0.04	0.04	0.03	0.040	0.015	0.030	0.040	0.040	0.040
Sulphur	0.04	0.04	0.04	0.04	0.03	0.030	0.015	0.030	0.040	0.020	0.040
Silicon	1.50	2.00	1.50	2.0	1.25	1.00	1.00	1.0	1.00	1.00	1.00
Nickel	9.0-12.0	8.0-11.0	9.0-13.0	8-12	Balance	Balance	Balance	38.0-44.0	4.7-6.0	4.5-6.5	6.0-8.0
Iron	-	-	-	-	3.50	4.5-7.5	5.0	Balance	-	-	-
Chromium	18.0-21.0	18.0-21.0	18.0-21.0	17.0-21.0	-	15.5-17.5	20.0-23.0	19.5-23.5	24.5-26.5	21.0-23.5	24.0-26.0
Niobium	-	-	-	-	0.5	(A)	3.15-4.50	0.60-1.20	-	-	-
Molybdenum	2.0-3.0	0.50	3.0-4.0	0.50	-	16.0-18.0	8.0-10.0	2.5-3.5	1.70-2.30	2.5-3.5	4.0-5.0
Copper	-	-	-	-	26.0-33.0	(A)	(A)	1.50-3.50	2.7-3.3	1.00	-
Tungsten	-	-	-	-	-	0.20-0.40	(A)	(A)	-	-	-
Nitrogen	-	-	-	-	-	-	-	-	0.10-0.25	0.10-0.30	0.10-0.30
Vanadium	-	-	-	-	-	0.20-0.40	(A)	(A)	-	-	-
Tensile Strength PSI minimum	70,000	77,000	75,000	70,000	65,000	72,000	72,000	75,000	100,000	90,000	100,000
Yield Strength PSI minimum	30,000	35,000	35,000	30,000	25,000	40,000	40,000	35,000	70,000	60,000	75,000
Elongation In 2" minimum	30.0	35.0	25.0	35.0	25.0	4.0	25.0	20.0	16.0	25.0	18.0

Notes: (A). Element to be analyzed and reported for information only. (B). Order M35-1 or M30C when weldability is required. 1. The percentage (%) shown on the elements is the maximum except where ranges are indicated. 2. Steel CF8C should have a Columbium content of not less than 8 times the carbon content, but not exceeding 1%.

API-603 CAST STAINLESS STEEL & SPECIAL ALLOY GATE VALVES, CLASS 150 CAST STEEL GATE VALVES, WITH RISING STEM AND OUTSIDE SCREW AND YOKE (OS&Y)

DESIGN FEATURES

- Gate valves design in accordance with API-603
- Standard manufacturing wedge flexible wedge
- Flange dimensions in accordance with ASME B16.5
- Gate and Globe Valves for cryogenic service with gas column in accordance with BS-6364 upon request
- Hand-wheel, impact hand-wheel, chain-wheel, electric, pneumatic or hydraulic actuation as per customer requirements
- By-Pass, lantern rings, grease injectors, special connections, etc.
- Low fugitive emissions control
- NACE service either MR-01-75 or MR-01-03
- Test in accordance with API-598

- ① Stem Nut, replaceable in line to avoid shut down of pipeline process.
- ② Rising stem with precision ACME single or double thread for quick operation. Surface finish suitable to seal properly to obtain low fugitive emissions.
- ③ Stem Packing is designed for optimum control of fugitive emissions leakage to the atmosphere. The ultra-low emission leakage rate is assured by the polished finish stem sealing area, the reduced diametrical clearances, and the stem straightness control special designed packing. Live load packing arrangement available upon request.
- ④ Integral backseat designed to relieve back pressure on the stem packing when fully seated. Replacing stem packing under pressure is not recommended. Hard faced backseat available for severe service as per customer requirements.
- ⑤ Stem-Gate connection designed so that under severe applied loads (stuck gate), the stem will fail outside of the stuffing box pressure boundary.
- ⑥ Body to Bonnet joint is designed to apply a uniform load to the gasket to assure a leak proof seal.
- ⑦ Integral seat rings designed to provide a bubble tight joint.
- ⑧ Stellite 6 overlay on wedge Seating Surfaces provide increased resistance to wear, abrasion and erosion.
- ⑨ Two-piece arrangement gland flange and stem packing bushing for self-alignment to avoid stem damage.
- ⑩ Gate valves supplied handwheel operated as standard.

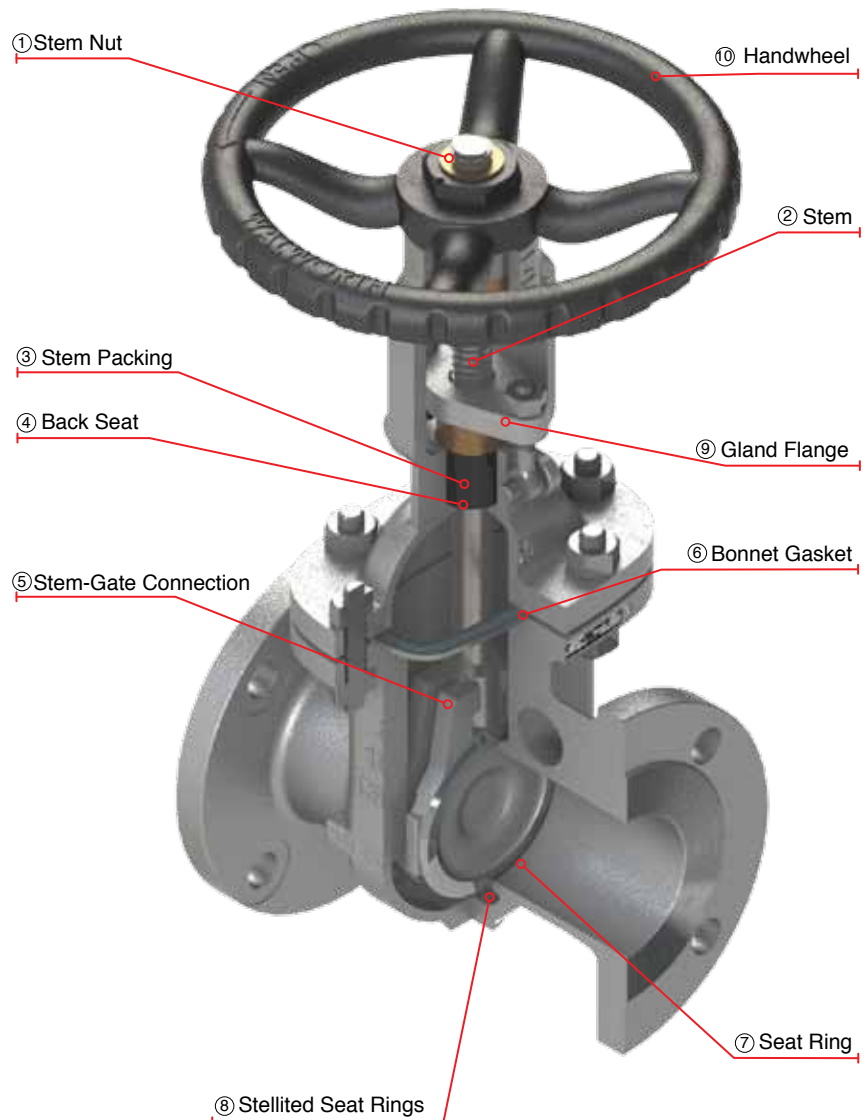

API-603 CAST STAINLESS STEEL & SPECIAL ALLOY GATE VALVES, CLASS 150 (INTEGRAL YOKE)

DESIGN FEATURES:

- Design in accordance with API - 603
- Outside Screw & Yoke (OS&Y)
- Flexible Wedge
- Handwheel operated as standard
- Integral Yoke
- Flange dimensions as per ASME B16.5
- End to end dimension as per ASME B16.10
- WE dimensions as per ASME B16.25

Catalog Figure No.	ID Plant Figure No.	Type of Ends
S5202RF	S5202F	Flanged Raised Face
S5202RTJ	S5202RJ	Ring Type Joint
S5202WE	S5202WE	Buttweld

Regular Bill of Materials

No.	Description	Standard Material CF8M Trim 3HF
1	Body	ASTM A 351 GR CF8M
2	Bonnet	ASTM A 351 GR CF8M
3	Wedge	ASTM A 351 GR CF8M + ST 6
*4	Seat Ring	Integral Seat Ring
5	Stem	ASTM A 276 Type 316
6	Stem Nut Retainer	ASTM A182 F304
7	Grease Fitting	Commercial Steel
8	Stem Nut	ASTM B 148 UNS C95600
9	Eyebolt	ASTM A193 B8
10	Eyebolt Nut	ASTM A 194 Gr 8
11	Gland Flange	ASTM A182 F304
12	Packing Bushing	ASTM A182 F316
13	Eyebolt Pin	Alloy Steel
14	Stem Packing	Flexible graphite intermediate rings / Anti-extrusion rings on the top and bottom sides of the packing chamber
15	Bonnet Gasket	Graphite/Stainless Steel 316
16	Bonnet Stud	ASTM A 193 GR B8
17	Bonnet Stud Nut	ASTM A 194 GR 8
18	Handwheel	Commercial
19	Handwheel Nut	ASTM A 108 GR 1020
20	Oppressor	Alloy Steel
21	Identification Plate	Stainless Steel

*Not shown

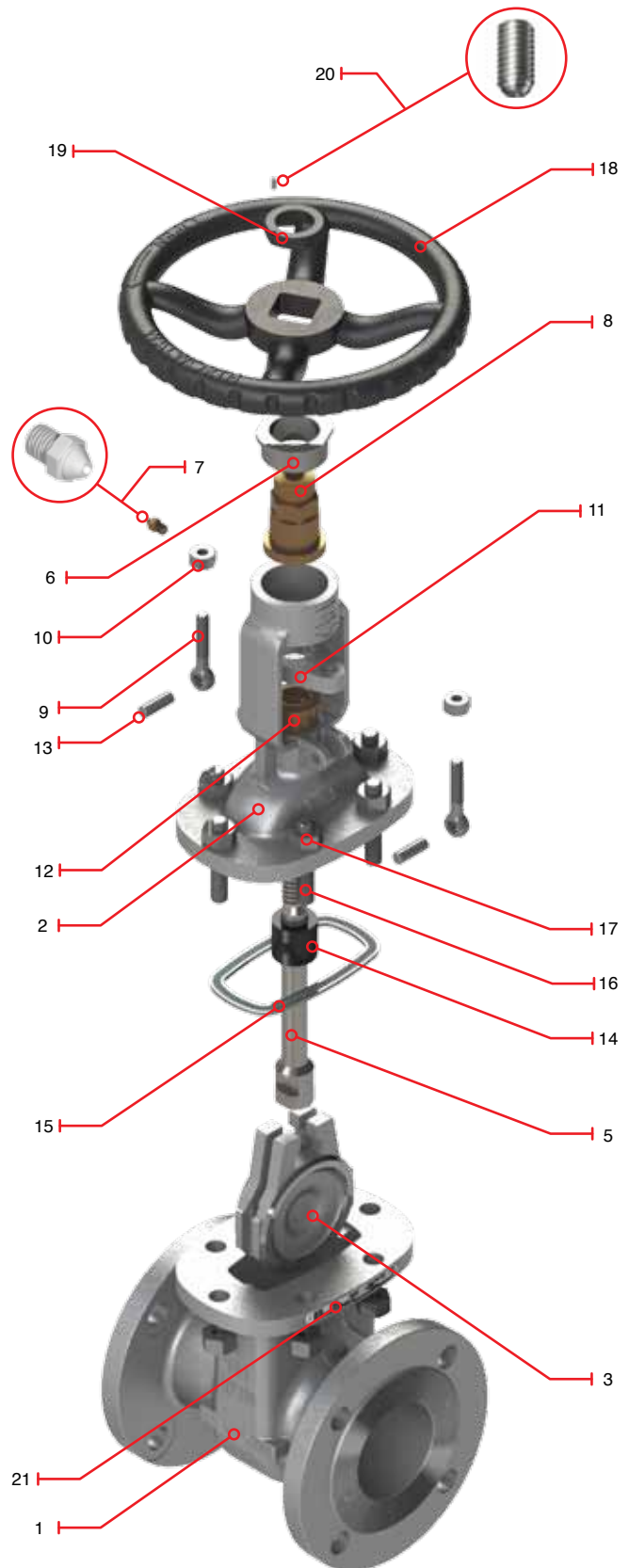

API-603 CAST STAINLESS STEEL & SPECIAL ALLOY GATE VALVES, CLASS 150 (INTEGRAL YOKE)

DESIGN FEATURES:

- Design in accordance with API - 603
- Outside screw & yoke (OS&Y)
- Flexible wedge
- Handwheel operated as standard
- Integral yoke
- Flange dimensions as per ASME B16.5
- End to end dimension as per ASME B16.10
- WE dimensions as per ASME B16.25



Catalog Figure No.	ID Plant Figure No.	Type of Ends
S5202RF	S5202F	Flanged Raised Face
S5202RTJ	S5202RJ	Ring Type Joint
S5202WE	S5202WE	Buttweld

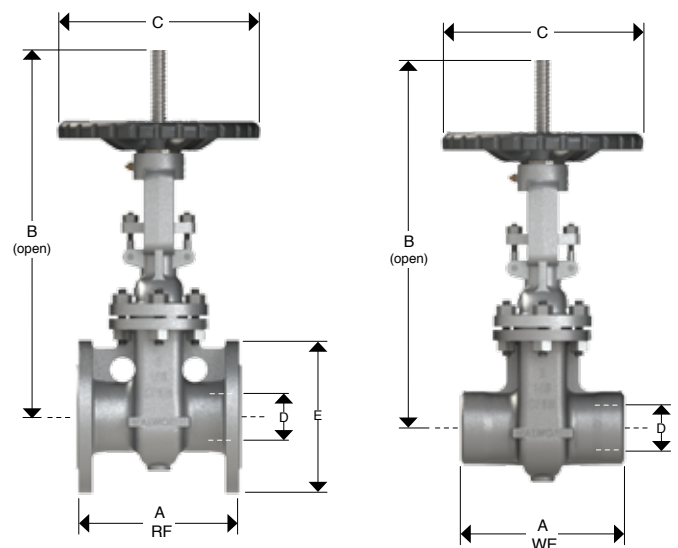

Dimensions and Weights

D Nominal Diameter	mm	51	64	76	102	152	203	254	305
	in	2	2.5	3	4	6	8	10	12
A (RF and RTJ)	mm	178	191	203	229	267	292	330	356
	in	7	7.5	8	9	10.5	11.5	13	14
A (WE)	mm	216	241	283	305	403	419	457	502
	in	8.5	9.5	11.13	12	15.88	16.5	18	19.75
B (Open)	mm	350	355	373	571	740	946	1130	1332
	in	13.8	14	14.7	22.5	29.1	37.2	44.5	52.4
C	mm	200	200	250	250	300	350	400	450
	in	7.9	7.9	9.8	9.8	11.8	13.8	15.7	17.7
E	mm	152	178	191	229	279	343	406	483
	in	6	7	7.5	9	11	13.5	16	19
Weight	Kg	13	18	22	32	53	88	135	204
S5202RF	lb	28.7	39.7	48.5	70.56	116.9	194	297.7	449.8
Weight	Kg	9	15	18	28	45	72	108	180
S5202WE	lb	19.8	33.1	39.7	61.7	99.2	158.8	238.1	396.9

API-603 CAST STAINLESS STEEL & SPECIAL ALLOY GATE VALVES, CLASS 150 (INDEPENDENT YOKE)

DESIGN FEATURES:

- Design in accordance with API - 603
- Outside screw & yoke (OS&Y)
- Flexible wedge
- Handwheel operated as standard
- Independent yoke
- Flange dimensions as per ASME B16.5
- End to end dimension as per ASME B16.10
- WE dimensions as per ASME B16.25

Catalog Figure No.	ID Plant Figure No.	Type of Ends
S5202RF	S5202F	Flanged Raised Face
S5202RTJ	S5202RJ	Ring Type Joint
S5202WE	S5202WE	Buttweld

Regular Bill of Materials

No.	Description	Standard Material CF8M Trim 3HF
1	Body	ASTM A 351 GR CF8M
2	Bonnet	ASTM A 351 GR CF8M
3	Wedge	ASTM A 351 GR CF8M + ST 6
*4	Seat Ring	Integral Seat Ring
5	Stem	ASTM A 276 Type 316
6	Stem Nut Retainer	ASTM A182 F304
7	Grease Fitting	Commercial Steel
8	Stem Nut	ASTM B 148 UNS C95600
9	Eyebolt	ASTM A193 B8
10	Eyebolt Nut	ASTM A 194 Gr 8
11	Gland Flange	ASTM A182 F304
12	Packing Bushing	ASTM A182 F316
13	Eyebolt Pin	Alloy Steel
14	Stem Packing	Flexible graphite intermediate rings / Anti-extrusion rings on the top and bottom sides of the packing chamber
15	Bonnet Gasket	Graphite/Stainless 316
16	Bonnet Stud	ASTM A 193 GR B8M
17	Bonnet Stud Nut	ASTM A 194 GR 8M
18	Handwheel	Commercial
19	Handwheel Nut	ASTM A 108 GR 1020
20	Opressor	Alloy Steel
21	Identification Plate	Stainless Steel
22	Yoke	ASTM A 351 GR CF8M
23	Yoke Bolt	ASTM A 193 GR B8
24	Yoke Bolt Nut	ASTM A 194 GR 8
25	Bearings	Commercial

*Not shown

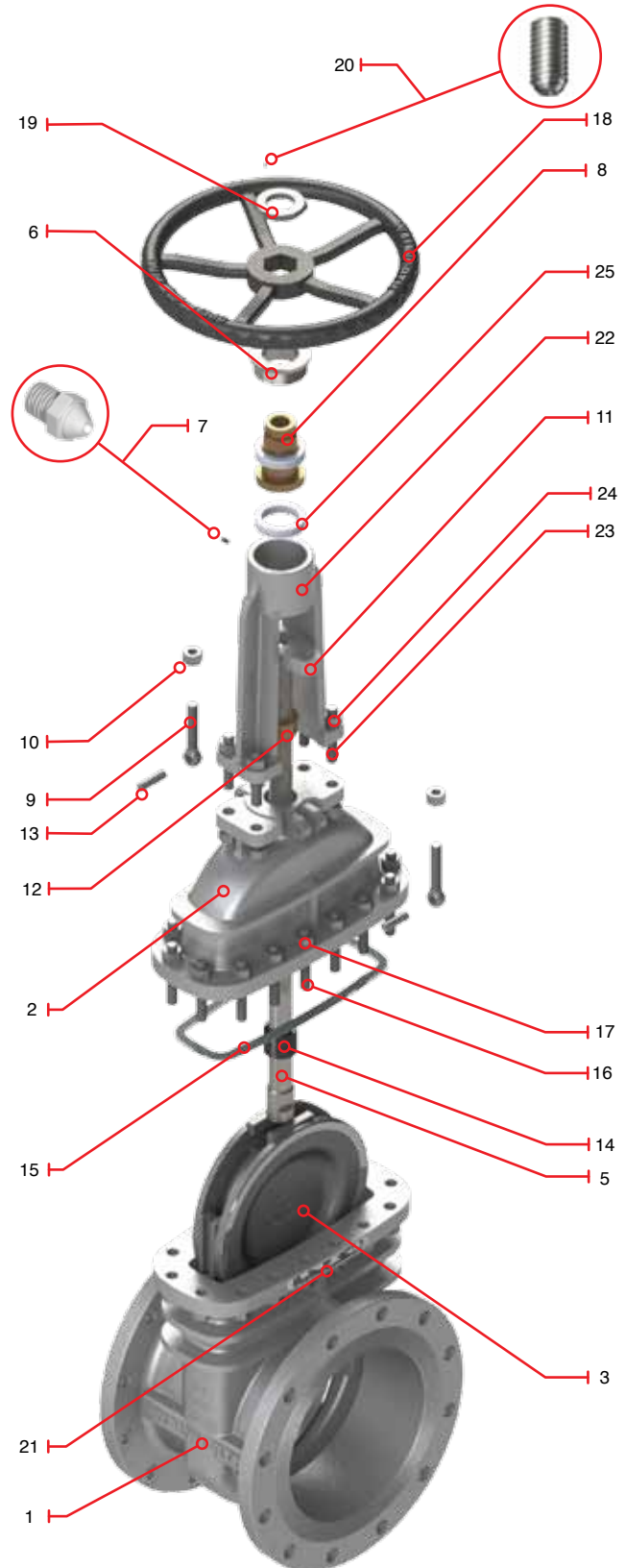

API-603 CAST STAINLESS STEEL & SPECIAL ALLOY GATE VALVES, CLASS 150 (INDEPENDENT YOKE)



DESIGN FEATURES:

- Design in accordance with API - 603
- Outside screw & yoke (OS&Y)
- Flexible wedge
- Handwheel operated as standard
- Independent yoke
- Flange dimensions as per ASME B16.5
- End to end dimension as per ASME B16.10
- WE dimensions as per ASME B16.25

Catalog Figure No.	ID Plant Figure No.	Type of Ends
S5202RF	S5202F	Flanged Raised Face
S5202RTJ	S5202RJ	Ring Type Joint
S5202WE	S5202WE	Buttweld

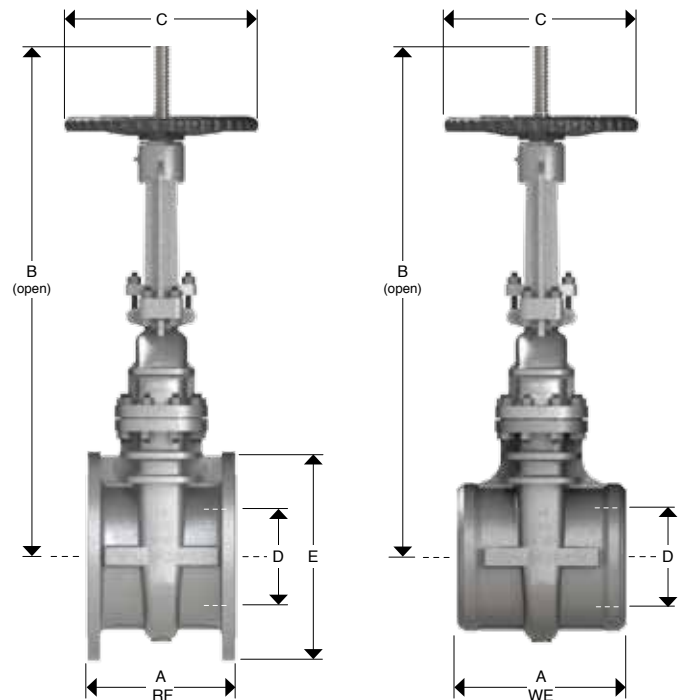

Dimensions and Weights

D Nominal Diameter	mm	356	406	457	508	610
	in	14	16	18	20	24
A	mm	381	406	432	457	508
	(RF) in	15	16	17	18	20
A	mm	572	610	660	711	813
	(WE) in	22.5	24	26	28	32
B	mm	1448	1680	1872	2058	2497
	in	57.0	66.1	73.7	81	98.3
C	mm	500	500	600	650	720
	in	19.7	19.7	23.6	25.6	28.3
E	mm	533	597	635	699	813
	in	21	23.5	25	27.5	32
Weight	Kg	349.2	459	540	826.2	1044
S5202RF	lb	770	1012.1	1190.7	1822	2302
Weight	Kg	317.2	424	457	542.2	652
S5202WE	lb	699.5	935	1007.7	1195.6	1437.7

API-603 CAST STAINLESS STEEL & SPECIAL ALLOY GATE VALVES, CLASS 300 CAST STEEL GATE VALVES, WITH RISING STEM AND OUTSIDE SCREW AND YOKE (OS&Y)

DESIGN FEATURES

- Gate valves design in accordance with API-603
- Standard manufacturing flexible wedge
- Flange dimensions in accordance with ASME B16.5
- Gate and Globe Valves for cryogenic service with gas column in accordance with BS-6364 upon request
- Hand-wheel, impact hand-wheel, chain-wheel, electric, pneumatic or hydraulic actuation as per customer requirements
- By-Pass, lantern rings, grease injectors, special connections, etc.
- Low fugitive emissions control
- NACE service either MR-01-75 or MR-01-03
- Test in accordance with API-598

- ① Stem Nut, replaceable in line to avoid shut down of pipe line process.
- ② Rising stem with precision ACME single or double thread for quick operation. Surface finish suitable to seal properly to obtain low fugitive emissions.
- ③ Stem Packing is designed for optimum control of fugitive emissions leakage to the atmosphere. The ultra-low emission leakage rate is assured by the polished finish stem sealing area, the reduced diametrical clearances, and the stem straightness control special designed packing. Live load packing arrangement available upon request.
- ④ Integral backseat designed to relieve back pressure on the stem packing when fully seated. Replacing stem packing under pressure is not recommended. Hard faced backseat available for severe service as per customer requirements.
- ⑤ Stem-Gate connection designed so that under severe applied loads (stuck gate), the stem will fail outside of the stuffing box pressure boundary.
- ⑥ Body to Bonnet joint is designed to apply a uniform load to the gasket to assure a leak proof seal.
- ⑦ Integral seat rings designed to provide a bubble tight joint.
- ⑧ Stellite 6 overlay on wedge Seating Surfaces provide increased resistance to wear, abrasion and erosion.
- ⑨ Two-piece arrangement gland flange and stem packing bushing for self-alignment to avoid stem damage.
- ⑩ Gate valves supplied handwheel operated as standard from 2" to 24".

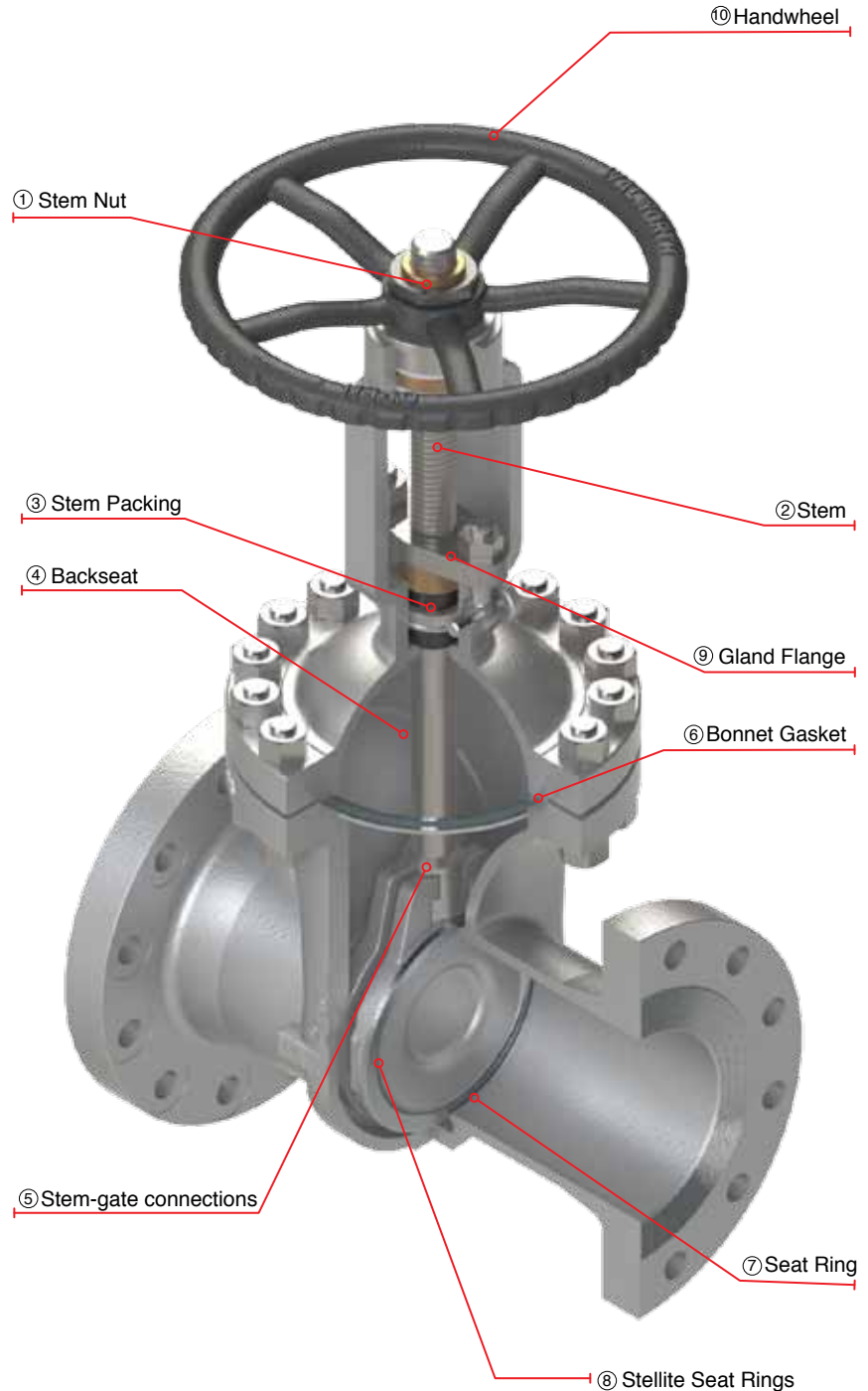

API-603 CAST STAINLESS STEEL & SPECIAL ALLOY GATE VALVES, CLASS 300 (INTEGRAL YOKE)

DESIGN FEATURES:

- Design in accordance with API-603
- Outside screw & yoke (OS&Y)
- Flexible wedge
- Handwheel operated as standard
- Integral yoke
- Flange dimensions as per ASME B16.5
- End to end dimensions as per ASME B16.10
- WE dimensions as per ASME B16.25

Catalog Figure No.	ID Plant Figure No.	Type of Ends
S5206RF	S5206F	Flanged Raised Face
S5206RTJ	S5206RJ	Ring T ype Joint
S5206WE	S5206WE	Buttweld

Regular Bill of Materials

No.	Description	Standard material
1	Body	ASTM A 351 GR CF8M
2	Bonnet	ASTM A 351 GR CF8M
3	Disc	ASTM A 351 GR CF8M + ST6
*4	Seat Ring	Integral Seat Ring
5	Stem	ASTM A182 F316
6	Stem Nut Retainer	ASTM A182 F304
7	Grease Fitting	Commercial Steel
8	Stem Nut	ASTM B 148 UNS C95600
9	Eyebolt	ASTM A193 B8
10	Eyebolt Nut	ASTM A194 Gr 8
11	Gland Flange	ASTM A182 F304
12	Packing Bushing	ASTM A182 F316
13	Eyebolt Pin	Alloy Steel
14	Stem Packing	Flexible graphite intermediate rings / Anti extrusion rings top and bottom side of packing chamber
15	Bonnet Gasket	Graphite / Stainless 316
16	Bonnet Stud	ASTM A 193 GR B8
17	Bonnet Stud Nut	ASTM A 194 GR 8
18	Handwheel	Commercial
19	Handwheel Nut	ASTM A 108 GR 1020
20	Opressor	Alloy Steel
21	Identification Plate	Stainless Steel
22	Lantern Ring	ASTM A182 F316

*Not Shown

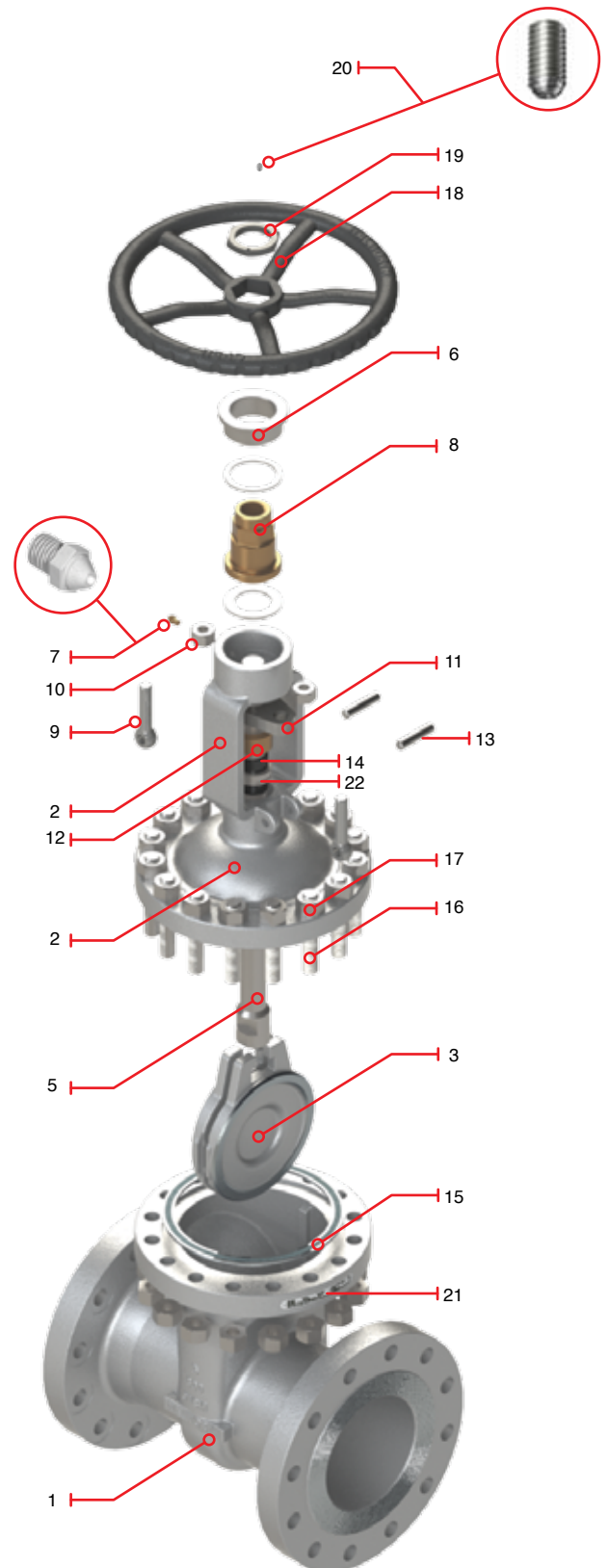

API-603 CAST STAINLESS STEEL & SPECIAL ALLOY GATE VALVES, CLASS 300 (INTEGRAL YOKE)



DESIGN FEATURES:

- Design in accordance with API-603
- Flexible wedge
- Outside screw & yoke (OS&Y)
- Handwheel operated as standard
- Independent yoke
- Flange dimensions as per ASME B16.5
- End to end dimensions as per ASME B16.10
- WE dimensions as per ASME B16.25

Catalog Figure No.	ID Plant Figure No.	Type of Ends
S5206RF	S5206F	Flanged Raised Face
S5206RTJ	S5206RJ	Ring Type Joint
S5206WE	S5206WE	Buttweld

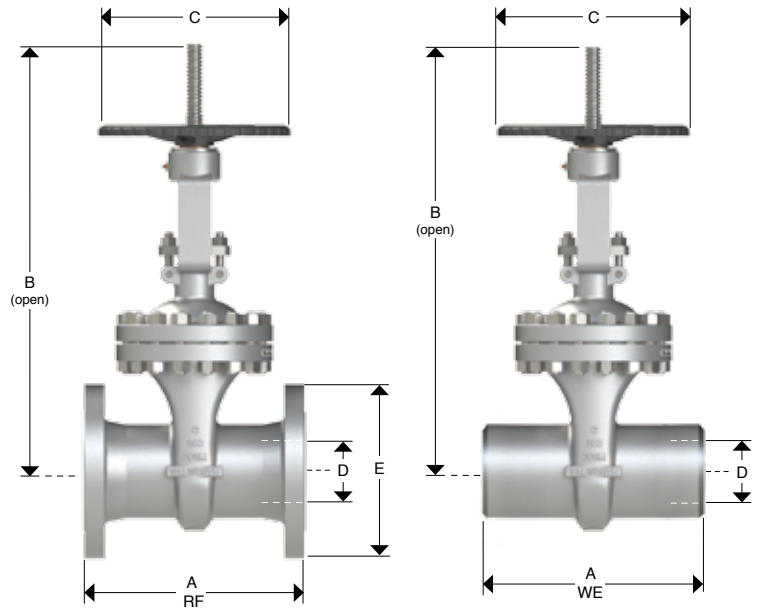

Dimensions and Weights

D Nominal Diameter	mm	51	64	76	102	152	203	254	305
	in	2	2.5	3	4	6	8	10	12
A (RF and WE)	mm	216	241	283	305	403	419	457	502
	in	8.5	9.5	11.13	12	15.88	16.5	18	19.75
B (Open)	mm	376	420	479	577	815	986	1123	1285
	in	14.8	16.5	18.9	22.7	32.1	38.8	44.2	50.6
C	mm	250	250	250	300	350	400	450	500
	in	9.8	9.8	9.8	11.8	13.8	15.7	17.7	19.7
E	mm	165	191	210	254	318	381	445	521
	in	6.5	7.5	8 ¼	10	12.5	15	17.5	20.5
Weight	Kg	19	27	36	55	102	169	268	377
S5206RF	lb	41.9	59.5	79.4	121.3	224.9	372.6	590.9	831.3
Weight	Kg	14	19	26	36	82	141.6	245.9	314.3
S5206WE	lb	30.9	41.9	57.3	79.4	180.8	312.2	542.2	693.0

API-603 CAST STAINLESS STEEL & SPECIAL ALLOY GATE VALVES, CLASS 300 (INDEPENDENT YOKE)

DESIGN FEATURES:

- Design in accordance with API-603
- Outside screw & yoke (OS&Y)
- Flexible wedge
- Handwheel operated as standard
- Independent yoke
- Flange dimensions as per ASME B16.5
- End to end dimensions as per ASME B16.10
- WE dimensions as per ASME B16.25

Catalog Figure No.	ID Plant Figure No.	Type of Ends
S5206RF	S5206F	Flanged Raised Face
S5206RTJ	S5206RJ	Ring Type Joint
S5206WE	S5206WE	Buttweld

Regular Bill of Materials

No.	Description	Standard Material CF8M Trim 3HF
1	Body	ASTM A 351 GR CF8M
2	Bonnet	ASTM A 351 GR CF8M
3	Disc	ASTM A 351 GR CF8M + ST6
*4	Seat Ring	Integral Seat Ring
5	Stem	ASTM A182 F316
6	Stem Nut Retainer	ASTM A182 F304
7	Grease Fitting	Commercial Steel
8	Stem Nut	ASTM B 148 UNS C95600
9	Eyebolt	ASTM A193 B8M
10	Eyebolt Nut	ASTM A194 Gr 8
11	Gland Flange	ASTM A182 F304
12	Packing Bushing	ASTM A182 F316
13	Eyebolt Pin	Alloy Steel
14	Stem Packing	Flexible graphite intermediate rings / Anti extrusion rings top and bottom side of packing chamber
15	Bonnet Gasket	Graphite / Stainless 316
16	Bonnet Stud	ASTM A 193 GR B8
17	Bonnet Stud Nut	ASTM A 194 GR 8
18	Handwheel	Commercial
19	Handwheel Nut	ASTM A 108 GR 1020
20	Opressor	Alloy Steel
21	Identification Plate	Stainless Steel
22	Lantern Ring	ASTM A182 F316
23	Yoke	ASTM A 351 GR CF8M
24	Yoke Bolt	ASTM A 193 GR B8
25	Yoke Bolt Nut	ASTM A 194 GR 8
26	Stem Nut Washer	Commercial

*Not Shown

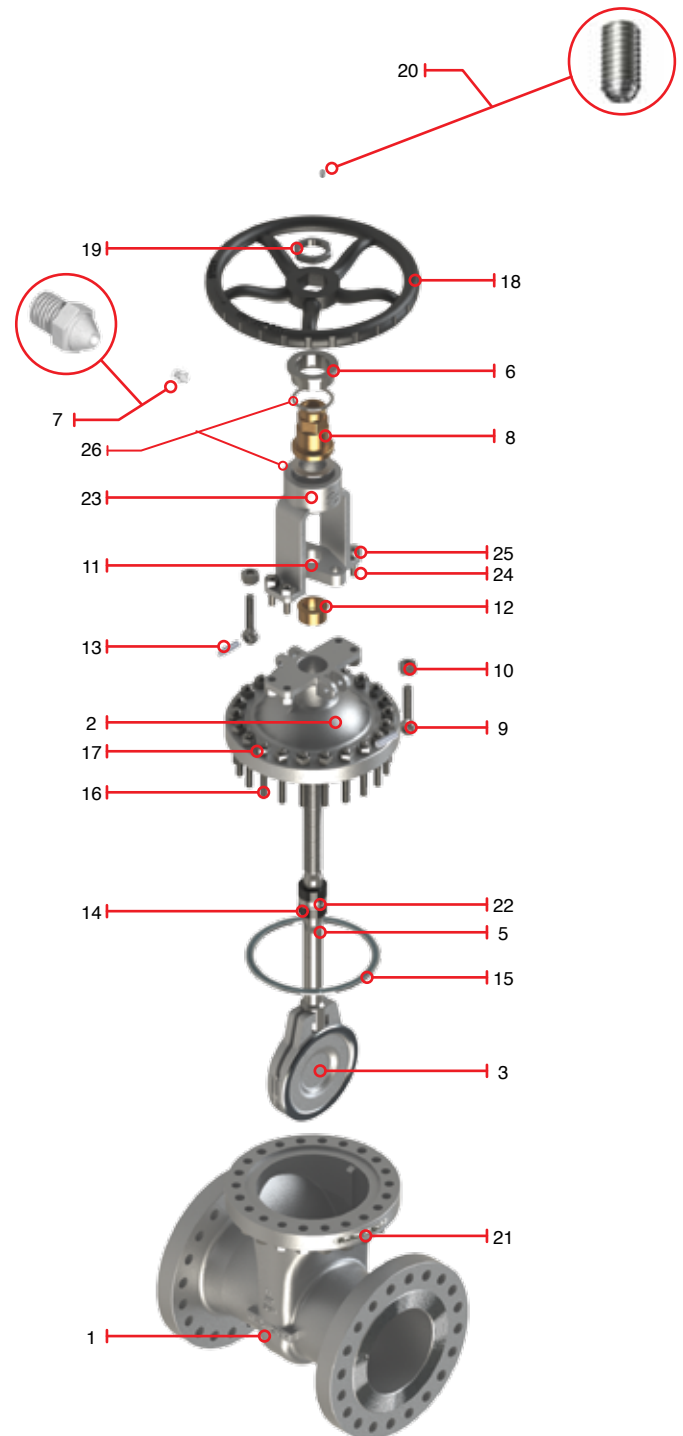

API-603 CAST STAINLESS STEEL & SPECIAL ALLOY GATE VALVES, CLASS 300 (INDEPENDENT YOKE)

DESIGN FEATURES

- Design in accordance with API-603
- Flexible wedge
- Outside screw & yoke (OS&Y)
- Handwheel operated as standard
- Independent yoke
- Flange dimensions as per ASME B16.5
- End to end dimensions as per ASME B16.10
- WE dimensions as per ASME B16.25



Catalog Figure No.	ID Plant Figure No.	Type of Ends
S5206RF	S5206F	Flanged Raised Face
S5206RTJ	S5206RJ	Ring Type Joint
S5206WE	S5206WE	Buttweld

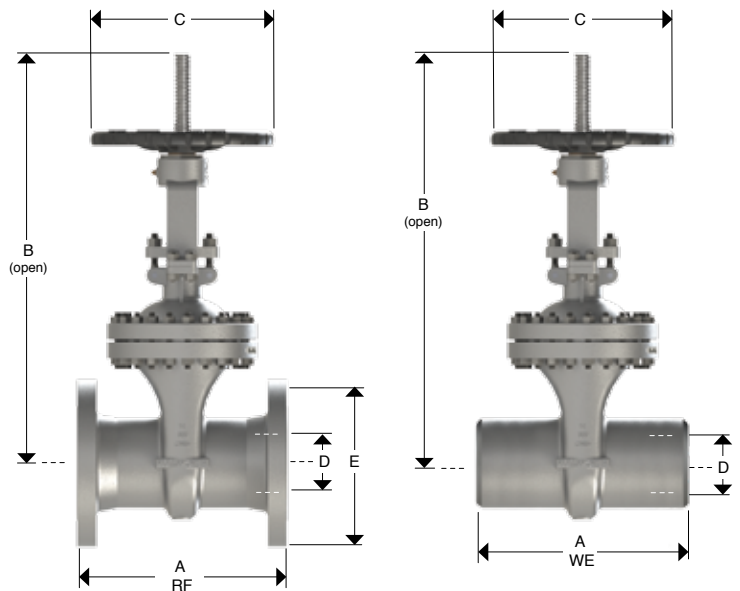

Dimensions and Weights

D Nominal Diameter	mm	356	406	457	508	610
	in	14	16	18	20	24
A (RF and WE)	mm	762	838	914	991	1143
	in	30	33	36	39	45
B (Open)	mm	1594	1730	1924	2105	2335
	in	62.75	68.13	75.75	82.88	91.88
C	mm	500	550	600	650	720
	in	19.7	21.7	23.6	25.6	28.3
E	mm	584	648	711	775	914
	in	23	25.5	28	30.5	36
Weight	Kg	816	1082	1469	1867	2200
S5206RF	lb	1799.3	2385.8	3239.1	4116.7	4851.0
Weight	Kg	725	923	1219	1582	1882
S5206WE	lb	1598.6	2035.2	2687.9	3488.3	4149.8

API-603 CAST STAINLESS STEEL & SPECIAL ALLOY GATE VALVES CLASS 600 CAST STEEL GATE VALVES, WITH RISING STEM AND OUTSIDE SCREW AND YOKE (OS&Y)

DESIGN FEATURES:

- Gate valves design in accordance with API-603
- Standard manufacturing flexible wedge
- Flange dimensions in accordance with ASME B16.5
- Gate and Globe Valves for cryogenic service with gas column in accordance with BS-6364 upon request
- Hand-wheel, impact hand-wheel, chain-wheel, electric, pneumatic or hydraulic actuation as per customer requirements
- By-Pass, lantern rings, grease injectors, special connections, etc.
- Low fugitive emissions control
- NACE service either MR-01-75 or MR-01-03
- Test in accordance with API-598

- ① Stem Nut, replaceable in line to avoid shut down of pipe line process.
- ② Rising stem with precision ACME single or double thread for quick operation. Surface finish suitable to seal properly to obtain low fugitive emissions.
- ③ Stem Packing is designed for optimum control of fugitive emissions leakage to the atmosphere. The ultra-low emission leakage rate is assured by the polished finish stem sealing area, the reduced diametrical clearances, and the stem straightness control special designed packing. Live load packing arrangement available upon request.
- ④ Integral Backseat designed to relieve back pressure on the stem packing when fully seated. Replacing stem packing under pressure is not recommended. Hard faced backseat available for severe service as per customer requirements.
- ⑤ Stem-Gate connection designed so that under severe applied loads (stuck gate), the stem will fail outside of the stuffing box pressure boundary.
- ⑥ Body to Bonnet ring type joint is designed to apply a uniform load to the gasket to assure a leak proof seal.
- ⑦ Integral seat rings to provide a bubble tight joint.
- ⑧ Stellite 6 overlay on wedge Seating Surfaces provide increased resistance to wear, abrasion and erosion.
- ⑨ Two-piece arrangement gland flange and stem packing bushing for self-alignment to avoid stem damage.
- ⑩ Gate and Globe valves supplied handwheel operated as standard.

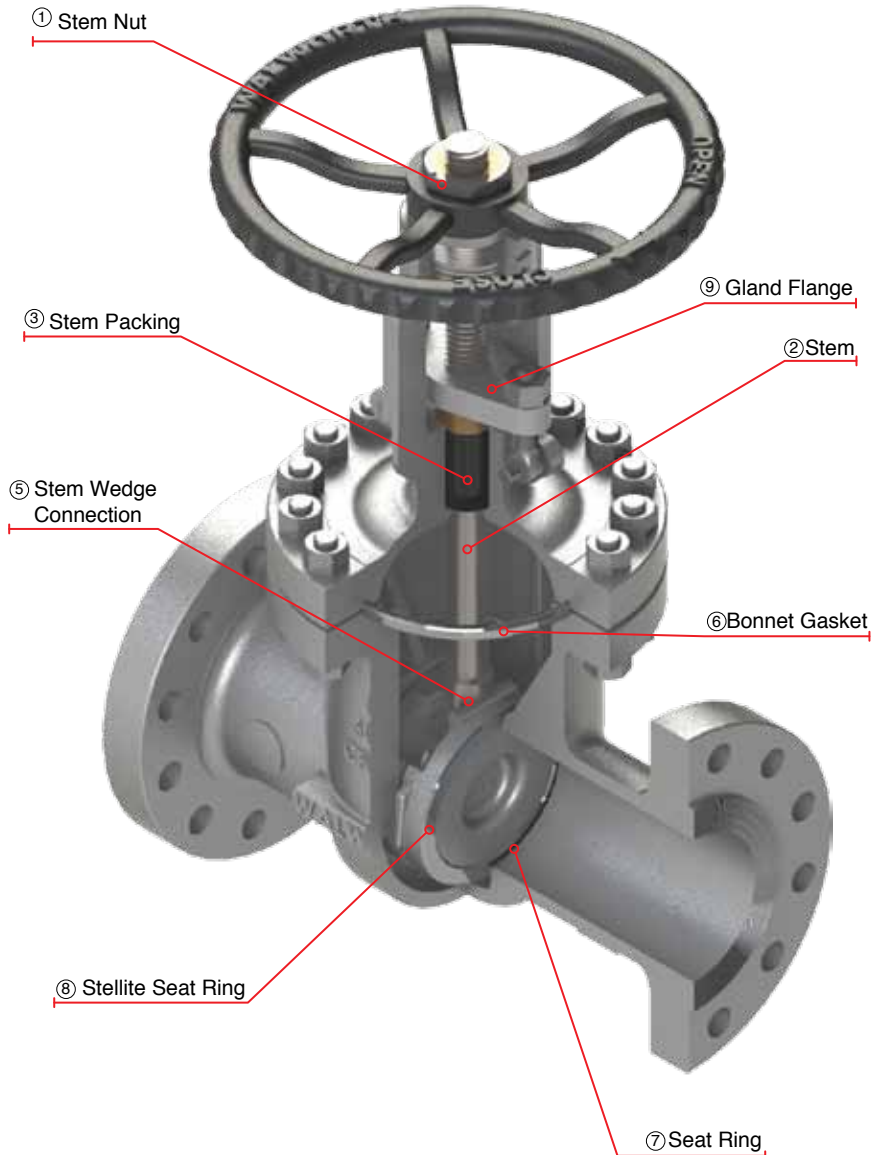

API-603 CAST STAINLESS STEEL & SPECIAL ALLOY GATE VALVES, CLASS 600 (INTEGRAL YOKE)

DESIGN FEATURES:

- Design in accordance with API-603
- Outside screw & yoke (OS&Y)
- Flexible wedge
- Handwheel operated as standard
- Integral yoke
- Flange dimensions as per ASME B16.5
- End to end dimensions as per ASME B16.10
- WE dimensions as per ASME B16.25

Catalog Figure No.	ID Plant Figure No.	Type of Ends
S5232RF	S5232F	Flanged Raised Face
S5232RTJ	S5232RJ	Ring Type Joint
S5232WE	S5232WE	Buttweld

Regular Bill of Materials

No.	Description	Standard Material CF8M Trim 3HF
1	Body	ASTM A 351 GR CF8M
2	Bonnet	ASTM A 351 GR CF8M
3	Disc	ASTM A 351 GR CF8M + ST 6
*4	Seat Ring	Integral Seat Ring
5	Stem	ASTM A 276 Type 316
6	Stem Nut Retainer	ASTM A182 F304
7	Grease Fitting	Commercial Steel
8	Stem Nut	ASTM B 148 UNS C95600
9	Eyebolt / Gland Flange Studs	A193 B8
10	Eyebolt Nut	ASTM A 194 Gr 8
11	Gland Flange	ASTM A182 F304
12	Packing Bushing	ASTM A182 F316
*13	Eyebolt Pin	Alloy Steel
14	Stem Packing	Flexible graphite intermediate rings / Anti-extrusion rings on the top and bottom sides of the packing chamber
**15	Bonnet Gasket	Graphite / Stainless 316
16	Ring Type Joint Gasket	ASTM A 182 F316
17	Bonnet Stud	ASTM A 193 GR B8
18	Bonnet Stud Nut	ASTM A 194 GR 8
19	Handwheel	Commercial
20	Handwheel Nut	ASTM A 108 GR 1020
21	Opressor	Alloy Steel
22	Stem Nut Bearing	Commercial Steel
*23	Identification Plate	Stainless Steel

*Not Shown

**Gasket used for smaller size valves

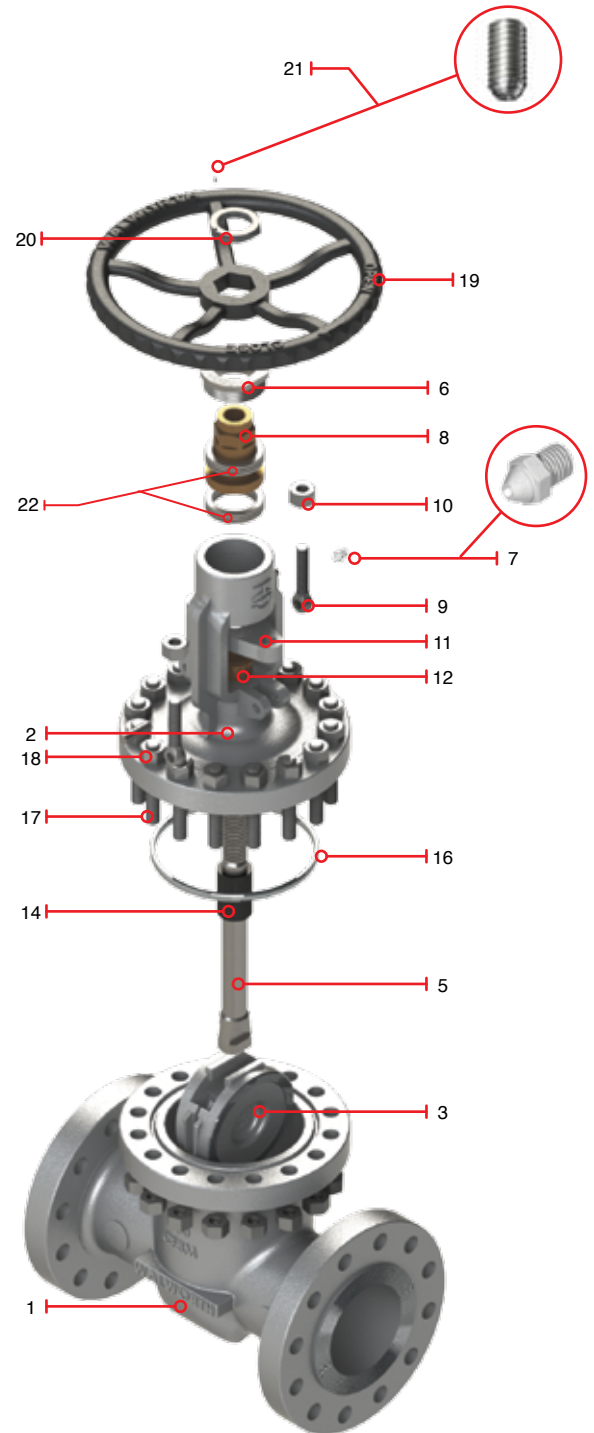

API-603 CAST STAINLESS STEEL & SPECIAL ALLOY GATE VALVES, CLASS 600 (INTEGRAL YOKE)

DESIGN FEATURES:

- Design in accordance with API-603
- Outside screw & yoke (OS&Y)
- Flexible wedge
- Handwheel operated as standard
- Flange dimensions as per ASME B16.5
- End to end dimensions as per ASME B16.10
- WE dimensions as per ASME B16.25



Catalog Figure No.	ID Plant Figure No.	Type of Ends
S5232RF	S5232F	Flanged Raised Face
S5232RTJ	S5232RJ	Ring Type Joint
5232WE	5232WE	Buttweld

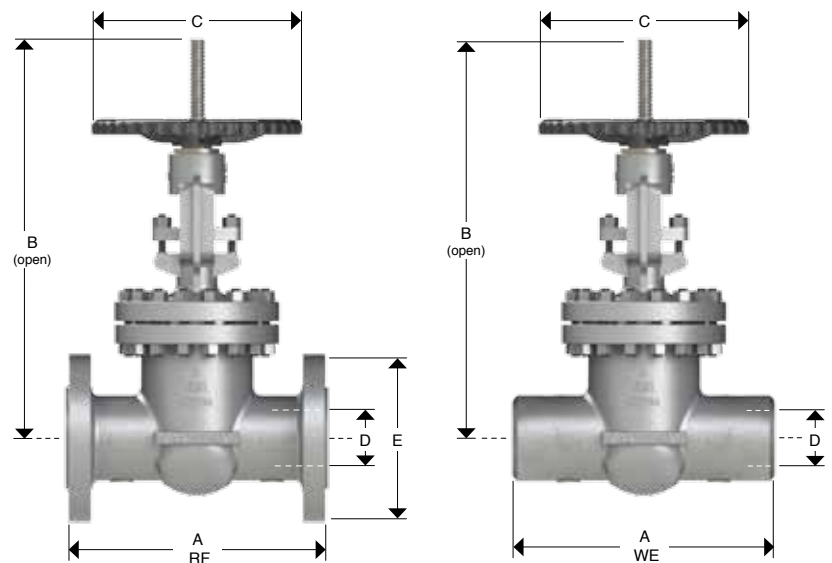

Dimensions and Weights

D Nominal Diameter	mm	50	65	80	100	150	200
	in	2	2 1/2	3	4	6	8
A (RF and WE)	mm	292	330	356	432	559	660
	in	11.5	13	14	17	22	26
B	mm	447.5	495	543	681	854	893
	in	17.6	19.5	21.4	26.8	33.6	35.2
C	mm	200	250	300	300	450	600
	in	7.9	9.8	11.8	11.8	17.7	23.6
E	mm	165	191	210	273	356	419
	in	6.5	7.5	8 ¼	10.75	14	16.5
Weight	Kg	24	36	53	93	190	338
5232RF/RTJ	lb	52.9	79.4	116.9	205.1	419.0	745.3
Weight 5232WE	Kg	22	24	39.5	78	161	293
	lb	48.5	52.9	87.1	172.0	355.0	646.1

API-603 CAST STAINLESS STEEL & SPECIAL ALLOY GATE VALVES, CLASS 600 (INDEPENDENT YOKE)

DESIGN FEATURES:

- Design in accordance with API-603
- Outside screw & yoke (OS&Y)
- Flexible wedge
- Handwheel operated as standard
- Independent yoke
- Flange dimensions as per ASME B16.5
- End to end dimensions as per ASME B16.10
- WE dimensions as per ASME B16.25

Catalog Figure No.	ID Plant Figure No.	Type of Ends
S5232RF	S5232F	Flanged Raised Face
S5232RTJ	S5232RJ	Ring Type Joint
S5232WE	S5232WE	Buttweld

Regular Bill of Materials

No.	Description	Standard Material CF8M Trim 3HF
1	Body	ASTM A 351 GR CF8M
2	Bonnet	ASTM A 351 GR CF8M
3	Disc	ASTM A 351 GR CF8M + ST 6
*4	Seat Ring	Integral Seat Ring
5	Stem	ASTM A 276 Type 316
6	Yoke	ASTM A 351 GR CF8M
7	Stem Nut Retainer	ASTM A182 F304
8	Grease Fitting	Commercial Steel
9	Stem Nut	ASTM B 148 UNS C95600
10	Eyebolt / Gland Flange Studs	A193 B8M
11	Eyebolt Nut	ASTM A 194 Gr 8
12	Gland Flange	ASTM A182 F304
13	Packing Bushing	ASTM A182 F316
14	Eyebolt Pin	Alloy Steel
15	Stem Packing	Flexible graphite intermediate rings / Anti-extrusion rings on the top and bottom sides of the packing chamber
**16	Bonnet Gasket	Graphite / Stainless 316
17	Ring Type Joint Gasket	ASTM A 182 F316
18	Bonnet Stud	ASTM A 193 GR B8M
19	Bonnet Stud Nut	ASTM A 194 GR 8M
20	Handwheel	Commercial
21	Handwheel Nut	ASTM A 108 GR 1020
22	Opressor	Alloy Steel
23	Yoke Bolt	ASTM A 193 GR B8M
24	Yoke Bolt Nut	ASTM A 194 GR 8M
25	Stem Nut Bearing	Commercial Steel
*26	Identification Plate	Stainless Steel

*Not Shown

**Gasket used for smaller size valves

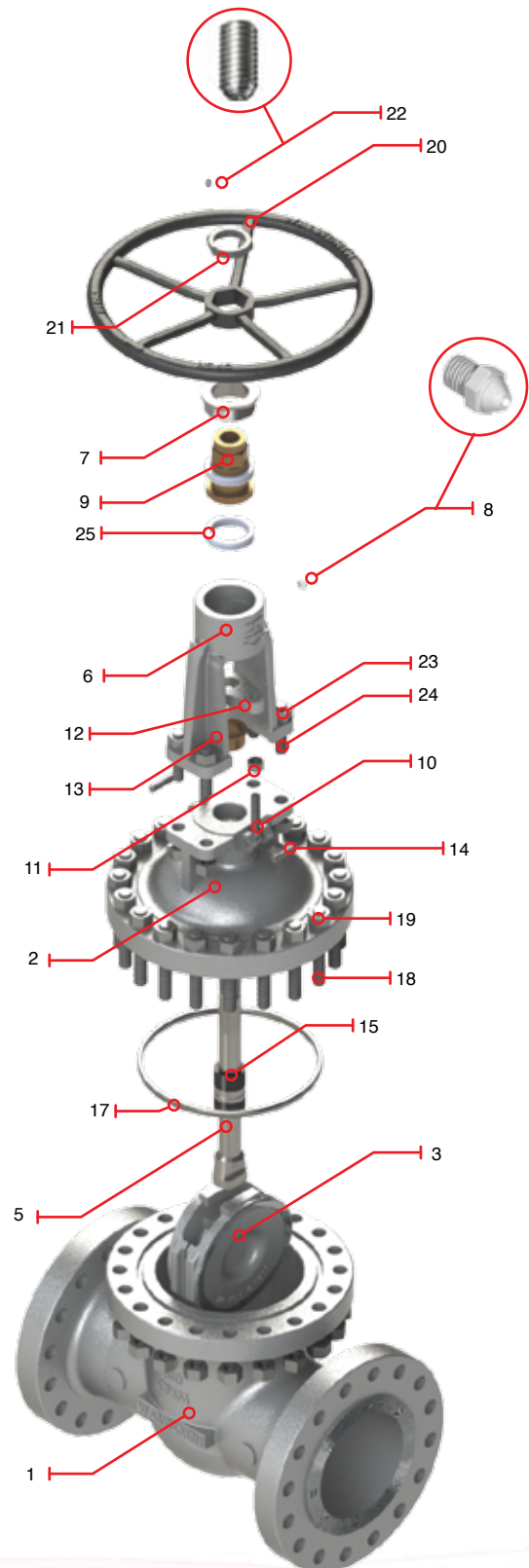

API-603 CAST STAINLESS STEEL & SPECIAL ALLOY GATE VALVES, CLASS 600 (INDEPENDENT YOKE)

DESIGN FEATURES:

- Design in accordance with API-603
- Outside screw & yoke (OS&Y)
- Flexible wedge
- Handwheel operated as standard
- Independent yoke
- Flange dimensions as per ASME B16.5
- End to end dimensions as per ASME B16.10
- WE dimensions as per ASME B16.25



Catalog Figure No.	ID Plant Figure No.	Type of Ends
5232RF	5232F	Flanged Raised Face
S5232RTJ	S5232RJ	Ring Type Joint
5232WE	5232WE	Buttweld

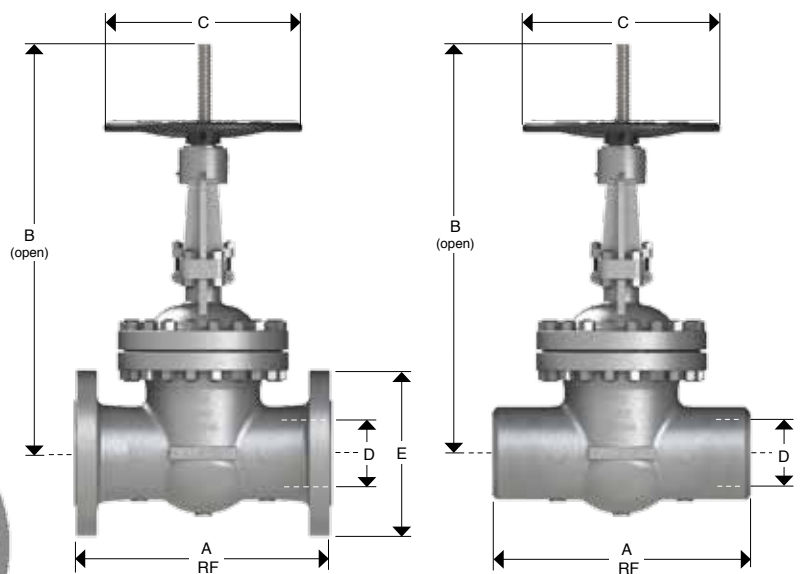

Dimensions and Weights

D Nominal Diameter	mm	254	305
	in	10	12
A (RF and WE)	mm	787	838
	in	31	33
B	mm	1295	1497
	in	51.0	58.9
C	mm	600	680
	in	23.6	26.8
E	mm	508	559
	in	20	22
Weight	Kg	556	750
5232RF	lb	1226.0	1653.8
Weight	Kg	480	638
5232WE	lb	1058.4	1406.8

API-603 CAST STAINLESS STEEL & SPECIAL ALLOY GLOBE VALVES, CLASS 150 CAST STEEL GLOBE VALVES WITH RISING HANDWHEEL AND STEM

DESIGN FEATURES:

- Globe valves designed in accordance with API-603
- Gate & Globe Valves for cryogenic service with gas column in accordance with BS-6364 upon request
- Flange dimensions in accordance with ASME B16.5
- Handwheel, handwheel impact, chain wheel, gear operation, electric, pneumatic or hydraulic actuation as per customer requirements
- By-pass, lantern rings, grease injectors, special connections, etc.
- Low fugitive emissions control
- NACE service either MR-01-75 or MR-01-03
- Test in accordance with API-598
- Stop check design option available

- ① Stem Nut, replaceable in line to avoid shut down of pipe line process.
- ② Revolving rising stem with precision ACME single or double thread for quick operation. Surface finish suitable to seal properly to get low fugitive emissions.
- ③ Stem Packing is designed for optimum control of fugitive emissions leakage to the atmosphere. The ultra low emission leakage rate is assured by the fine finish in the stem, the reduced diametrical clearances, and the stem straightness control special designed packing. Live load packing arrangement available upon request.
- ④ Integral Backseat designed to relieve back pressure on the stem packing when fully seated. Replacing stem packing under pressure is not recommended. Hard faced backseat available for severe service as customer requirements.
- ⑤ Body to Bonnet Joint designed to apply a uniform load to the gasket to assure a leak proof seal.
- ⑥ Conical plug type disc, integrally guided to assure true alignment between disc and valve body. The disc design allows the disc and seat ring sealing surface to seat correctly without damage.
- ⑦ Integral Seat Ring.
- ⑧ Two-piece arrangement gland flange and stem packing bushing for self-alignment to avoid stem damage.
- ⑨ Globe valves supplied Handwheel operated as standard from 2" to 24".

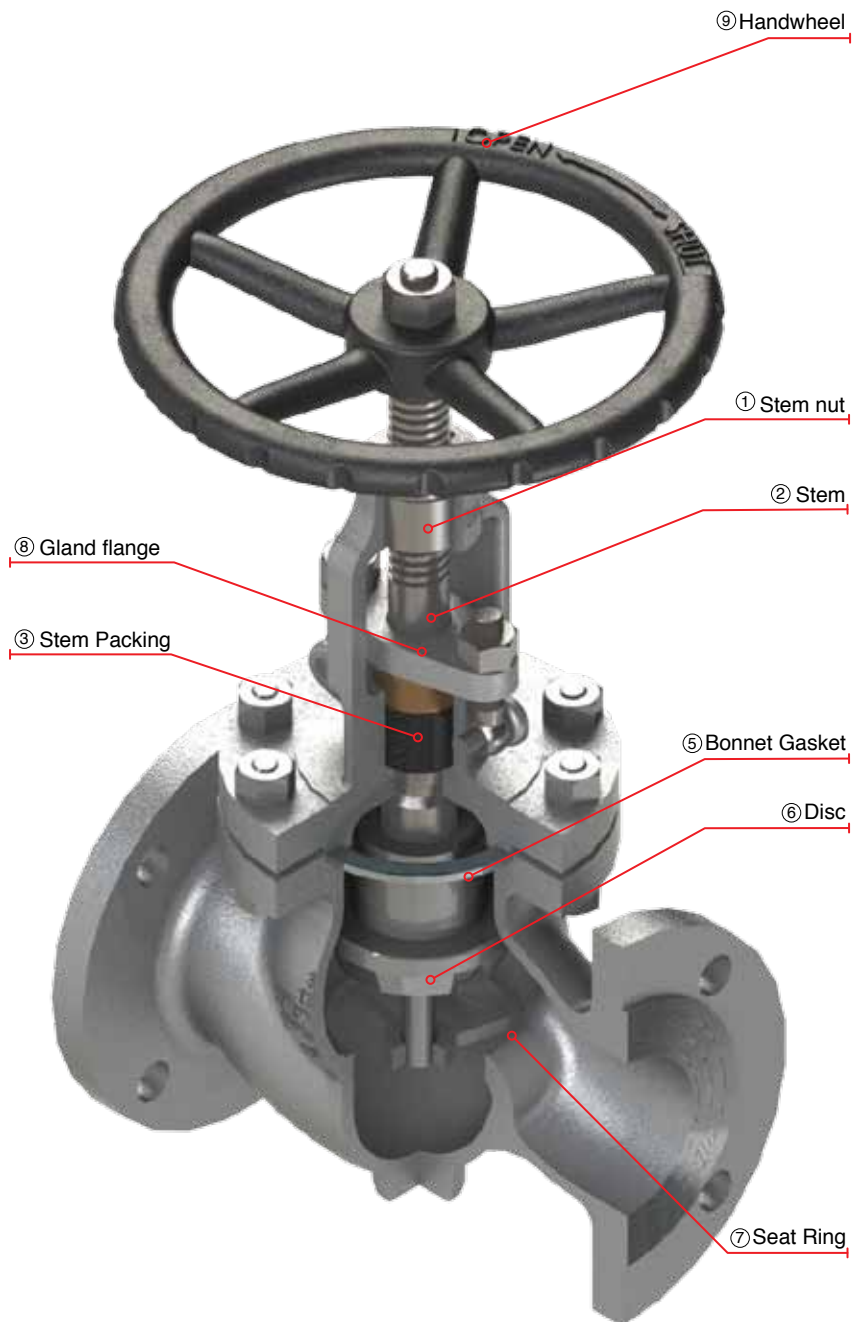

API-603 CAST STAINLESS STEEL & SPECIAL ALLOY GLOBE VALVES, CLASS 150 (INTEGRAL YOKE)

DESIGN FEATURES:

- Design in accordance with API-603
- Rising stem and handwheel
- Integral yoke
- Flange dimensions as per ASME B16.5
- End to end dimensions as per ASME B16.10
- WE dimensions as per ASME B 16.25
- Handwheel operated as standard

Catalog Figure No.	ID Plant Figure No.	Type of Ends
S5275RF	S5275F	Flanged Raised Face
S5275RTJ	S5275RJ	Ring Type Joint
S5275WE	S5275WE	Buttweld

Regular Bill of Materials

No.	Description	Standard Material CF8M Trim 3HF
1	Body	ASTM A 351 GR CF8M
2	Bonnet	ASTM A 351 GR CF8M
3	Disc	ASTM A 351 Gr CF8M + ST 6
*4	Seat Ring	Integral Seat Ring
5	Stem	ASTM A 476 Type 316
6	Stem Retainer	ASTM A 182 Type F316
7	Stem Nut	UNS C95600
*8	Stem Seat	ASTM A 476 Gr 316 + ST 6
9	Eyebolt	ASTM A 193 GR B8
10	Eyebolt Nut	ASTM A 194 GR 8
11	Gland Flange	ASTM A 351 GR CF8M
12	Packing Bushing	ASTM A 476 Type 316
13	Eyebolt Pin	Alloy Steel
14	Stem Packing	Flexible graphite intermediate rings / Anti-extrusion rings on the top and bottom sides of the packing chamber
15	Oppressor	Commercial
16	Bonnet Gasket	Spirotallic Graphite / Stainless 316
17	Bonnet Stud	ASTM A 193 GR B8
18	Bonnet Stud Nut	ASTM A 194 GR 8
19	Handwheel	As per WALWORTH design
20	Handwheel Nut	ASTM A 108 GR 1020
*21	Handwheel Washer	ASTM A 108 GR 1020
*22	Identification Plate	Stainless Steel

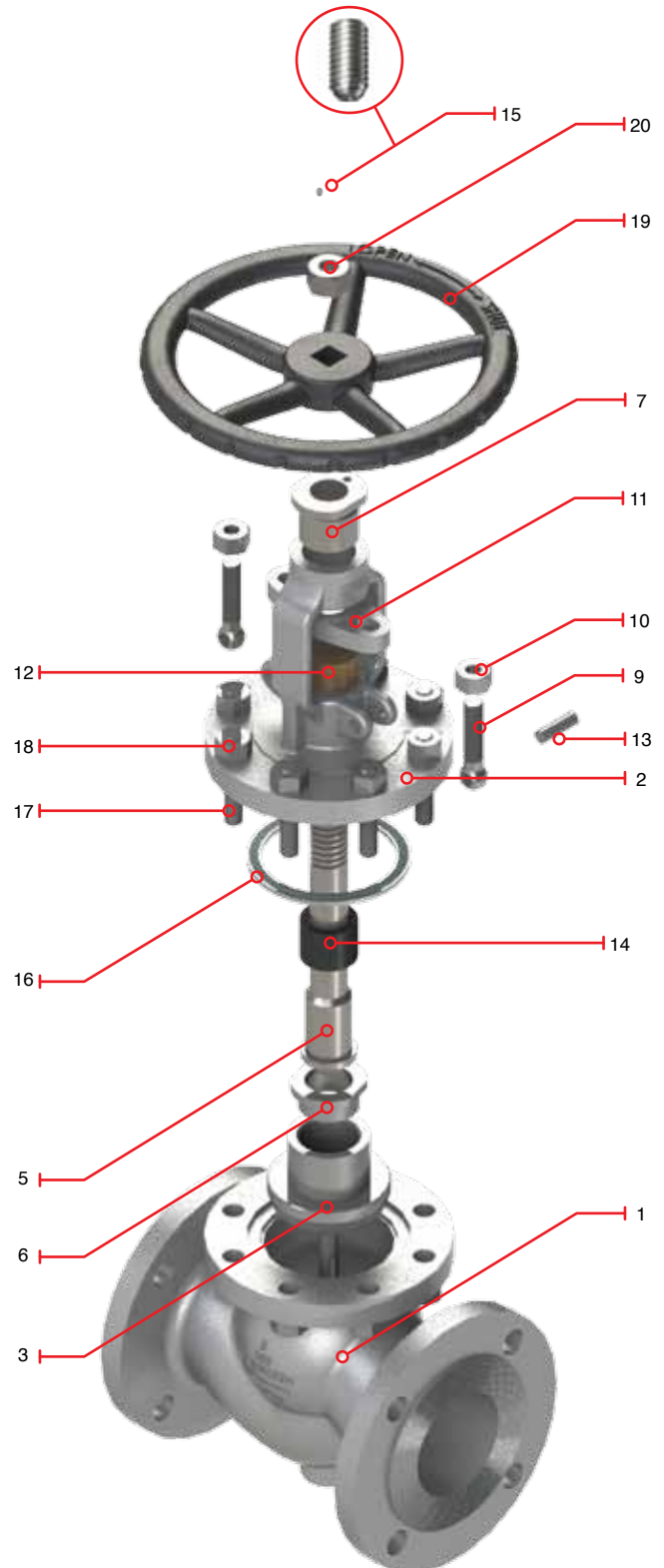

*Not Shown

API-603 CAST STAINLESS STEEL & SPECIAL ALLOY GLOBE VALVES, CLASS 150 (INTEGRAL YOKE)



DESIGN FEATURES:

- Design in accordance with ASME B 16.34
- Integral yoke
- Rising stem and handwheel
- Flange dimensions as per ASME B16.5
- End to end dimensions as per ASME B16.10
- WE dimensions as per ASME B 16.25
- Handwheel operated as standard

Catalog Figure No.	ID Plant Figure No.	Type of Ends
S5275RF	S5275F	Flanged Raised Face
S5275RTJ	S5275RJ	Ring Type Joint
S5275WE	S5275WE	Buttweld

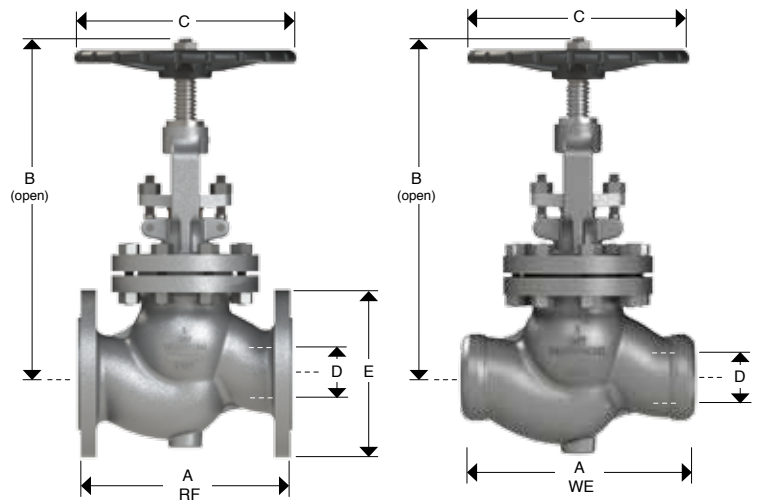

Dimensions and Weights

D Nominal Diameter	mm	51	64	76	102	152	203	254	305
	in	2	2.5	3	4	6	8	10	12
A (RF and WE)	mm	203	216	241	292	406	495	622	699
	in	8	8.5	9.5	11.5	16	19.5	24.5	27.5
B (Open)	mm	275	320	374	424	497	624	648	810
	in	10.8	12.6	14.7	16.7	19.6	24.6	25.5	31.9
C	mm	200	250	250	300	350	450	500	550
	in	7.9	9.8	9.8	11.8	13.8	17.7	19.7	21.7
E	mm	152	178	191	229	279	343	406	483
	in	6	7	7.5	9	11	13.5	16	19
Weight S5275RF	Kg	14	19	24	36	68	98	200	299
	lb	30.9	41.9	52.9	79.4	149.9	216.1	441.0	659.3
Weight S5275WE	Kg	11	15	15	26	52	67	166	241
	lb	24.3	33.1	33.1	57.3	114.7	147.7	366.0	531.4

For sizes and dimensions not shown, please contact our Sales Department.

API-603 CAST STAINLESS STEEL & SPECIAL ALLOY

GLOBE VALVES, CLASS 150 (INDEPENDENT YOKE)

DESIGN FEATURES:

- Design in accordance with API-603
- Rising stem and handwheel
- Independent yoke
- Flange dimensions as per ASME B16.5
- End to end dimensions as per ASME B16.10
- WE dimensions as per ASME B 16.25
- Handwheel operated as standard

Catalog Figure No.	ID Plant Figure No.	Type of Ends
S5275RF	S5275F	Flanged Raised Face
S5275RTJ	S5275RJ	Ring Type Joint
S5275WE	S5275WE	Buttweld

Regular Bill of Materials

No.	Description	Standard Material CF8M Trim 3HF
1	Body	ASTM A 351 GR CF8M
2	Bonnet	ASTM A 351 GR CF8M
3	Disc	ASTM A 351 Gr CF8M + ST 6
4	Yoke	ASTM A 351 GR CF8M
*5	Seat Ring	Integral Seat Ring
6	Stem	ASTM A 476 Type 316
7	Stem Retainer	ASTM A 182 Type F316
8	Stem Nut	UNS C95600
*9	Stem Seat	ASTM A 476 Gr 316 + ST 6
10	Eyebolt	ASTM A 193 GR B8
11	Eyebolt Nut	ASTM A 194 GR 8
12	Gland Flange	ASTM A 351 GR CF8M
13	Packing Bushing	ASTM A 476 Type 316
14	Eyebolt Pin	Alloy Steel
15	Stem Packing	Flexible graphite intermediate rings / Anti-extrusion rings on the top and bottom sides of the packing chamber
16	Opressor	Commercial
17	Bonnet Gasket	Spirotallic Graphite / Stainless 316
18	Yoke Bolt	ASTM A 193 GR B8
19	Yoke Bolt Nut	ASTM A 194 GR 8
20	Bonnet Stud	ASTM A 193 GR B8
21	Bonnet Stud Nut	ASTM A 194 GR 8
22	Handwheel	As per WALWORTH design
23	Handwheel Nut	ASTM A 108 GR 1020
*24	Handwheel Washer	ASTM A 108 GR 1020
*25	Identification Plate	Stainless Steel

*Not Shown

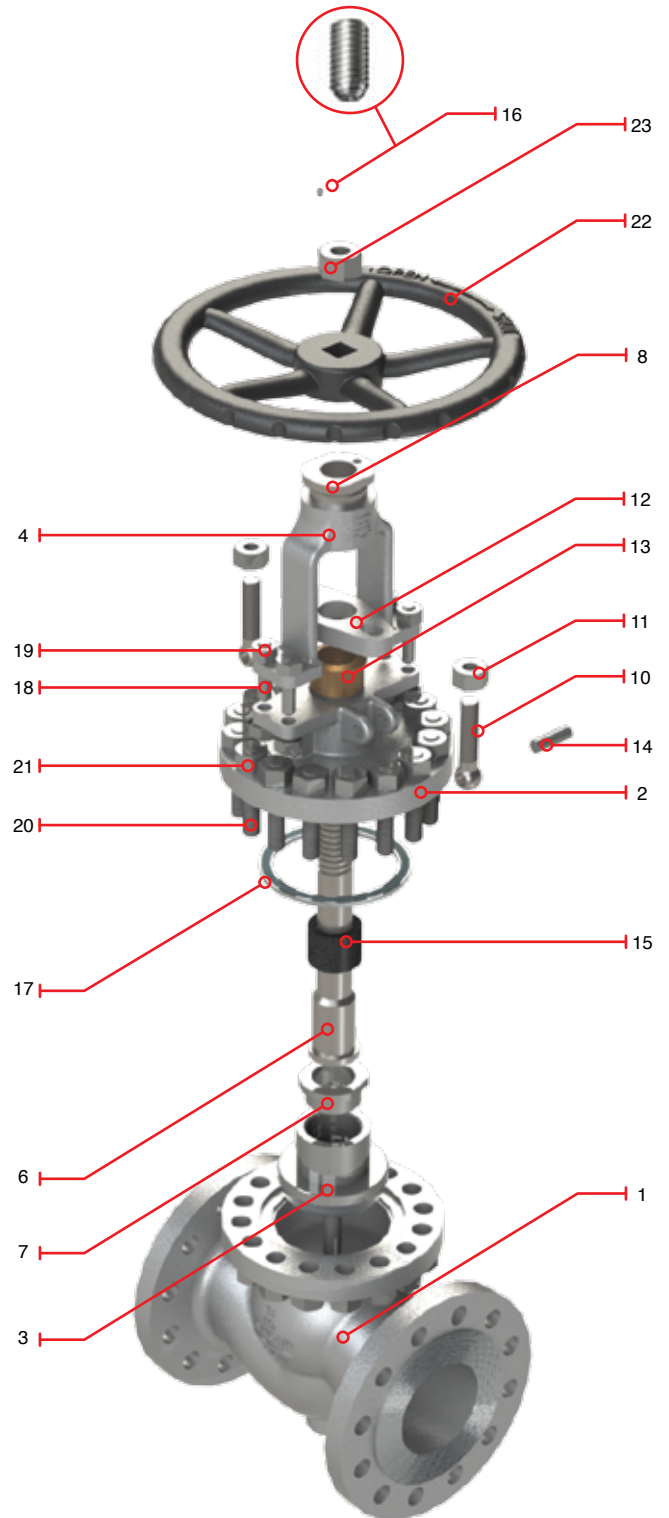

API-603 CAST STAINLESS STEEL & SPECIAL ALLOY

GLOBE VALVES, CLASS 150 (INDEPENDENT YOKE)



DESIGN FEATURES:

- Design in accordance with API-603
- Integral yoke
- Rising stem and handwheel
- Flange dimensions as per ASME B16.5
- End to end dimensions as per ASME B16.10
- WE dimensions as per ASME B 16.25
- Handwheel operated as standard

Catalog Figure No.	ID Plant Figure No.	Type of Ends
S5275RF	S5275F	Flanged Raised Face
S5275RTJ	S5275RJ	Ring Type Joint
S5275WE	S5275WE	Buttweld

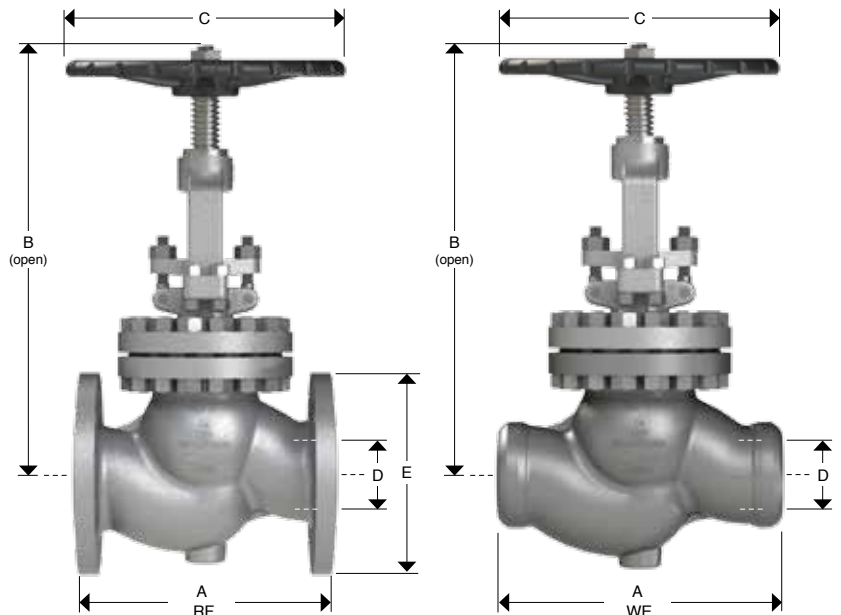

Dimensions and Weights

D Nominal Diameter	mm	350	400	450	500	600
	in	14	16	18	20	24
A (RF and WE)	mm	787	914	978	978	1295
	in	31	36	38.5	38.5	51
B (Open)	mm	970	986	1210	1307	1500
	in	38.2	38.8	47.6	51.5	59.1
C	mm	550	600	600	650	720
	in	21.7	23.6	23.6	25.6	28.3
E	mm	533	597	635	699	813
	in	21	23.5	25	27.5	32
Weight S5275RF	Kg	397.5	508.5	748.5	822.75	1209.75
	lb	876.5	1121.2	1650.4	1814.2	2667.5
Weight S5275WE	Kg	339.5	433.5	638.5	701.75	1032.75
	lb	748.6	955.9	1407.9	1547.4	2277.2

For sizes and dimensions not shown, please contact our Sales Department.

API-603 CAST STAINLESS STEEL & SPECIAL ALLOY

GLOBE VALVES CLASS 300

CAST STEEL GLOBE VALVES WITH RISING HANDWHEEL AND STEM

DESIGN FEATURES:

- Globe valves design in accordance with API-603
- Gate & globe valves for cryogenic service with gas column in accordance with BS-6364 upon request
- Flange dimensions in accordance with ASME B16.5
- Handwheel, handwheel impact, chain wheel, gear operation, electric, pneumatic or hydraulic actuation as per customer requirements
- By-pass, lantern rings, grease injectors, special connections, etc.
- Low fugitive emissions control
- NACE service either MR-01-75 or MR-01-03
- Test in accordance with API-598
- Stop check design option available

- ① Stem Nut, replaceable in line to avoid shut down of pipe line process.
- ② Revolving rising stem with precision ACME single or double thread for quick operation. Surface finish suitable to seal properly to get low fugitive emissions.
- ③ Stem Packing is designed for optimum control of fugitive emissions leakage to the atmosphere. The ultra low emission leakage rate is assured by the fine finish in the stem, the reduced diametrical clearances, and the stem straightness control special designed packing. Live load packing arrangement available upon request.
- ④ Integral Backseat designed to relieve back pressure on the stem packing when fully seated. Replacing stem packing under pressure is not recommended. Hard faced backseat available for severe service as customer requirements.
- ⑤ Body to Bonnet Joint designed to apply a uniform load to the gasket to assure a leak proof seal.
- ⑥ Conical plug type disc, integrally guided to assure true alignment between disc and valve body. The disc design allows the disc and seat ring sealing surface to seat correctly without damage.
- ⑦ Integral Seat Ring.
- ⑧ Two-piece arrangement gland flange and stem packing bushing for self-alignment to avoid stem damage.
- ⑨ Globe Valves supplied handwheel operated as standard from 2" to 24".

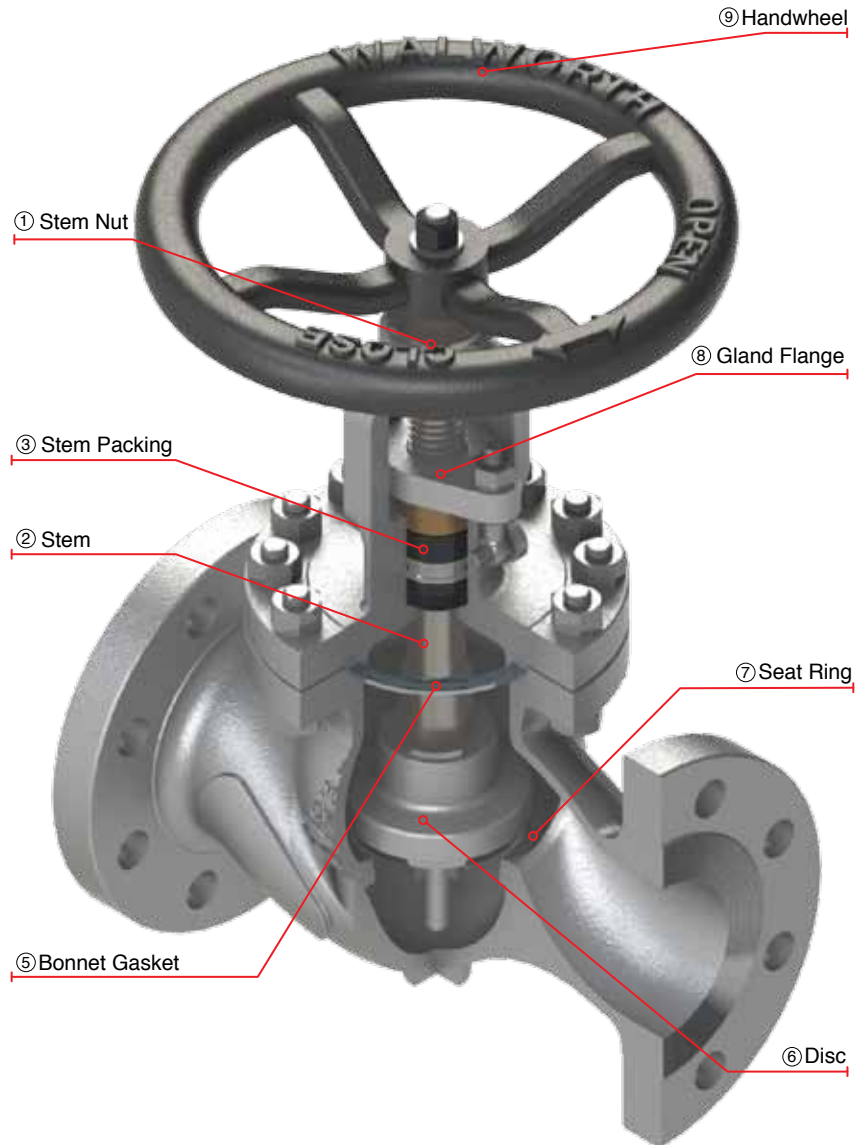

API-603 CAST STAINLESS STEEL & SPECIAL ALLOY GLOBE VALVES, CLASS 300 (INTEGRAL YOKE)

DESIGN FEATURES:

- Design in accordance with API-603
- Rising stem and handwheel
- Integral yoke
- Flange dimensions as per ASME B16.5
- End to end dimensions as per ASME B16.10
- WE dimensions as per ASME B 16.25
- Handwheel operated as standard

Catalog Figure No.	ID Plant Figure No.	Type of Ends
S5281RF	S5281F	Flanged Raised Face
S5281RTJ	S5281RJ	Ring Type Joint
5281WE	S5281WE	Buttweld

Regular Bill of Materials

No.	Description	Standard Material CF8M Trim 3HF
1	Body	ASTM A 351 GR CF8M
2	Bonnet	ASTM A 351 GR CF8M
3	Disc	ASTM A 351 Gr CF8M + ST 6
*4	Seat Ring	Integral Seat Ring
5	Stem	ASTM A 476 Type 316
6	Stem Retainer	ASTM A 182 Type F316
7	Stem Nut	UNS C95600
8	Stem Seat	ASTM A 476 Gr 316 + ST 6
9	Eyebolt	ASTM A 193 GR B8
10	Eyebolt Nut	ASTM A 194 GR 8
11	Gland Flange	ASTM A 351 GR CF8M
12	Packing Bushing	ASTM A 476 Type 316
13	Eyebolt Pin	Alloy Steel
14	Stem Packing	Flexible graphite intermediate rings / Anti-extrusion rings on the top and bottom sides of the packing chamber
15	Lantern Ring	ASTM A 182 Type F316
16	Opressor	Commercial
17	Bonnet Gasket	Spirotallic Graphite / Stainless 316
18	Bonnet Stud	ASTM A 193 GR B8
19	Bonnet Stud Nut	ASTM A 194 GR 8
20	Handwheel	As per WALWORTH design
21	Handwheel Nut	ASTM A 108 GR 1020
22	Handwheel Washer	ASTM A 108 GR 1020
*23	Identification Plate	Stainless Steel

*Not Shown

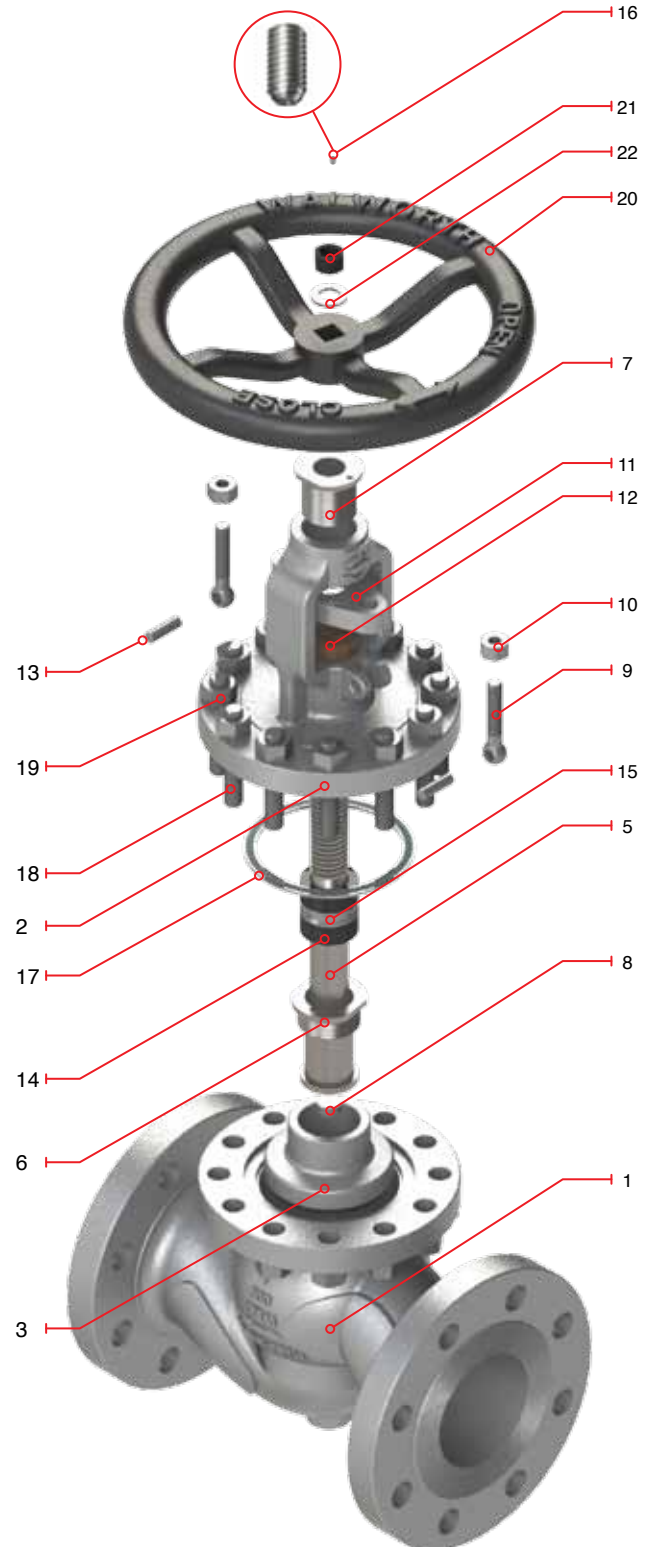

API-603 CAST STAINLESS STEEL & SPECIAL ALLOY GLOBE VALVES, CLASS 300 (INTEGRAL YOKE)

DESIGN FEATURES:

- Design in accordance with ASME B 16.34
- Rising stem and handwheel
- Flange dimensions as per ASME B16.5
- End to end dimensions as per ASME B16.10
- WE dimensions as per ASME B 16.25
- Size 2" to 12" handwheel operated as standard



Catalog Figure No.	ID Plant Figure No.	Type of Ends
S5281RF	S5281F	Flanged Raised Face
S5281RTJ	S5281RJ	Ring Type Joint
S5281WE	S5281WE	Buttweld

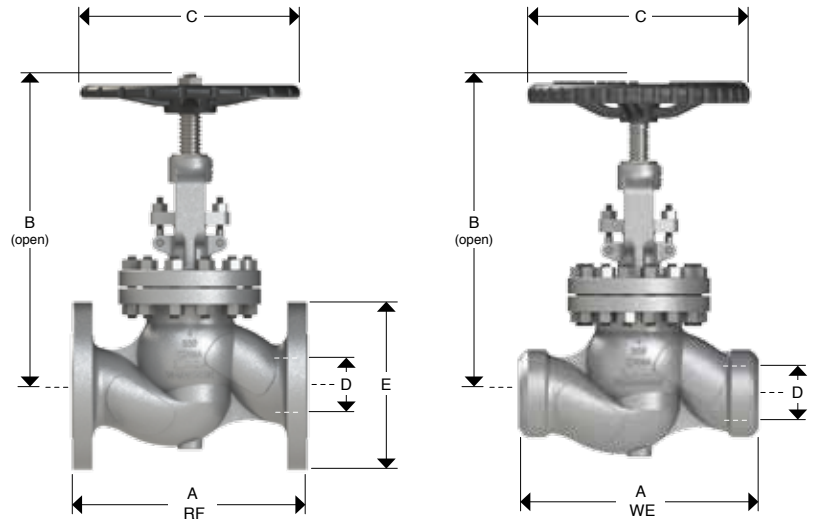

Dimensions and Weights

D Nominal Diameter	mm	50	65	80	100	150	200	250	300
	in	2	2.5	3	4	6	8	10	12
A (RF and WE)	mm	267	292	318	356	444	559	622	711
	in	10.5	11.5	12.5	14	17.5	22	24.5	28
B (Open)	mm	300	340	400	463	586	804	928	1125
	in	11.8	13.4	15.7	18.2	23.1	31.7	36.5	44.3
C	mm	200	250	250	300	400	400	450	500
	in	7.9	9.8	9.8	11.8	15.7	15.7	17.7	19.7
E	mm	165	191	210	254	318	381	445	521
	in	6.5	7.5	8 ¼	10	12.5	15	17.5	20.5
Weight S5281RF/RTJ	Kg	12	28	38	54	113	220.5	345.8	506.3
	lb	26.5	61.7	83.8	119.1	249.2	486.2	762.4	1116.3
Weight S5281WE	Kg	6	20	28	38	85	180.5	265.8	407.3
	lb	13.2	44.1	61.7	83.8	187.4	398.0	586.0	898.0

For sizes and dimensions not shown, please contact our Sales Department.

API-603 CAST STAINLESS STEEL & SPECIAL ALLOY GLOBE VALVES, CLASS 300 (INDEPENDENT YOKE)

DESIGN FEATURES:

- Design in accordance with API-603
- Independent yoke
- Flange dimensions as per ASME B16.5
- End to end dimensions as per ASME B16.10
- WE dimensions as per ASME B 16.25
- Handwheel operated as standard

Catalog Figure No.	ID Plant Figure No.	Type of Ends
S5281RF	S5281F	Flanged Raised Face
S5281RTJ	S5281RJ	Ring Type Joint
5281WE	5281WE	Buttweld

Regular Bill of Materials

No.	Description	Standard Material CF8M Trim 3HF
1	Body	ASTM A 351 GR CF8M
2	Bonnet	ASTM A 351 GR CF8M
3	Disc	ASTM A 351 Gr CF8M + ST 6
4	Yoke	ASTM A 351 GR CF8M
*5	Seat Ring	Integral Seat Ring
6	Stem	ASTM A 476 Type 316
7	Stem Retainer	ASTM A 182 Type F316
8	Stem Nut	UNS C95600
9	Stem Seat	ASTM A 476 Gr 316 + ST 6
10	Eyebolt	ASTM A 193 GR B8
11	Eyebolt Nut	ASTM A 194 GR 8
12	Gland Flange	ASTM A 351 GR CF8M
13	Packing Bushing	ASTM A 476 Type 316
14	Eyebolt Pin	Alloy Steel
15	Stem Packing	Flexible graphite intermediate rings / Anti-extrusion rings on the top and bottom sides of the packing chamber
16	Lantern Ring	ASTM A 182 Type F316
17	Opressor	Commercial
18	Bonnet Gasket	Spirotallic Graphite / Stainless 316
19	Yoke Bolt	ASTM A 193 GR B8
20	Yoke Bolt Nut	ASTM A 194 GR 8
21	Bonnet Stud	ASTM A 193 GR B8
22	Bonnet Stud Nut	ASTM A 194 GR 8
23	Handwheel	As per WALWORTH design
24	Handwheel Nut	ASTM A 108 GR 1020
25	Handwheel Washer	ASTM A 108 GR 1020
*26	Identification Plate	Stainless Steel

*Not Shown

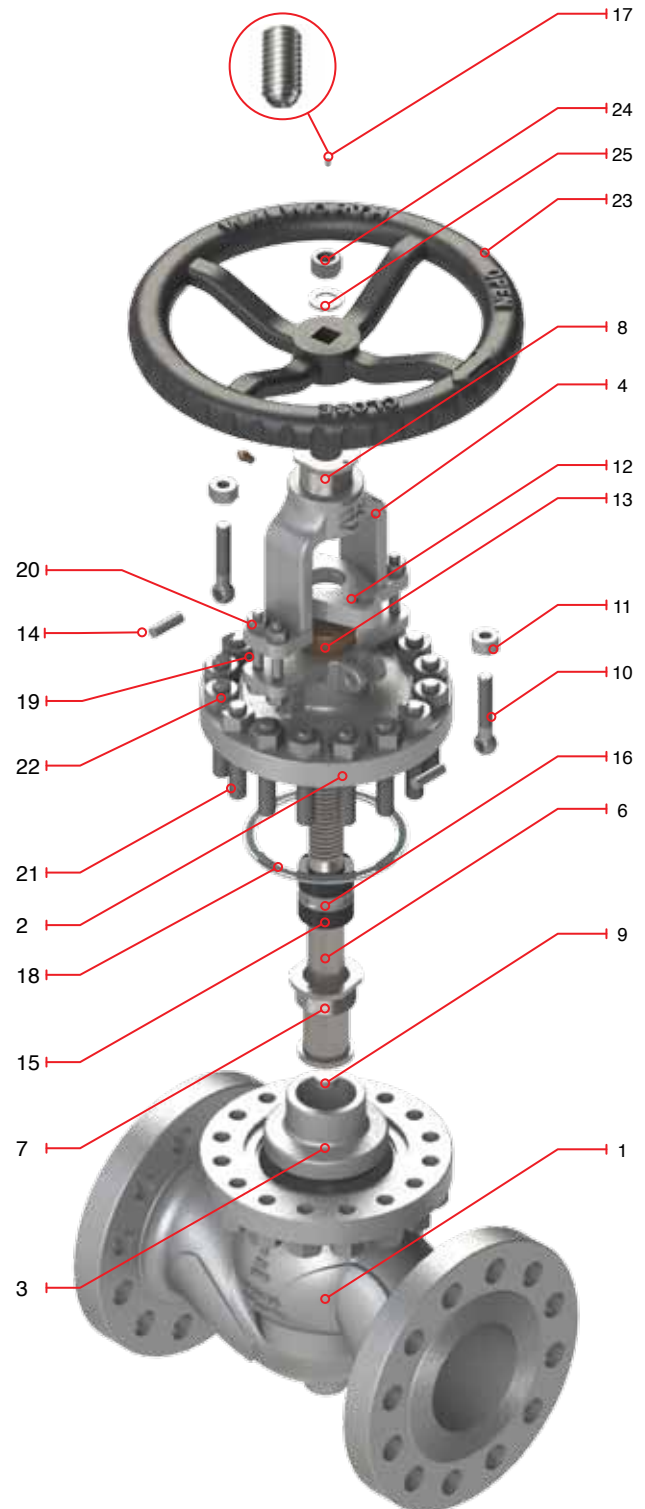

API-603 CAST STAINLESS STEEL & SPECIAL ALLOY GLOBE VALVES, CLASS 300 (INDEPENDENT YOKE)

DESIGN FEATURES:

- Design in accordance with API-603
- Rising stem
- Integral yoke
- Flange dimensions as per ASME B16.5
- End to end dimensions as per ASME B16.10
- WE dimensions as per ASME B 16.25
- Handwheel operated as standard



Catalog Figure No.	ID Plant Figure No.	Type of Ends
S5281RF	S5281F	Flanged Raised Face
S5281RTJ	S5281RJ	Ring Type Joint
S5281WE	S5281WE	Buttweld

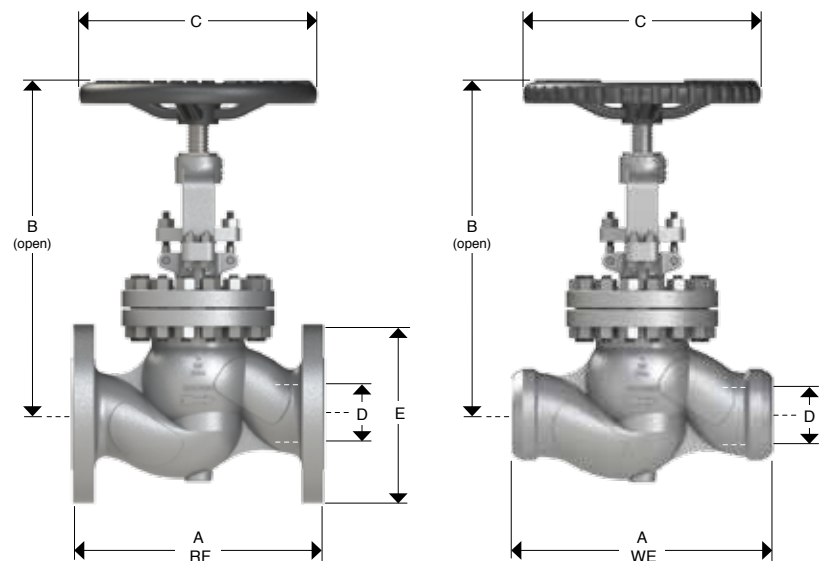

Dimensions and Weights

D Nominal Diameter	mm	350	400	450	500	600
	in	14	16	18	20	24
A (RF and WE)	mm	838	864	977	1016	1346
	in	33	34	38.5	40	53
B (Open)	mm	1173	1180	1250	1392	1480
	in	46.2	46.5	49.2	54.8	58.3
C	mm	500	550	600	650	720
	in	19.7	21.7	23.6	25.6	28.3
E	mm	584	648	711	775	914
	in	23	25.5	28	30.5	36
Weight S5281RF	Kg	590.3	822.8	1430.3	1589.25	1753.5
	lb	1301.5	1814.2	3153.7	3504.3	3866.5
Weight S5281WE	Kg	472.25	657.8	1201.3	1335.25	1472.5
	lb	1041.3	1450.3	2648.8	2944.2	3246.9

For sizes and dimensions not shown, please contact our Sales Department.

API-603 CAST STAINLESS STEEL & SPECIAL ALLOY GLOBE VALVES, CLASS 600 CAST STEEL GLOBE VALVES WITH RISING STEM AND OUTSIDE SCREW AND YOKE (OS&Y)

DESIGN FEATURES:

- Globe valves design in accordance with API-603
- Gate & globe valves for cryogenic service with gas column in accordance with BS-6364 upon request
- Flange dimensions in accordance with ASME B16.5 for valves up to 24" nominal diameter
- Handwheel, handwheel impact, chain wheel, gear operation, electric, pneumatic or hydraulic actuation as per customer requirements
- By-pass, lantern rings, grease injectors, special connections, etc.
- Low fugitive emissions control
- NACE service either MR-01-75 or MR-01-03
- Test in accordance with API-598
- Stop check design option available

- ① Stem nut, replaceable in line to avoid shut down of pipe line process.
- ② Revolving non rising stem with precision ACME single or double thread for quick operation. Surface finish suitable to seal properly to get low fugitive emissions.
- ③ Stem packing is designed for optimum control of fugitive emissions leakage to the atmosphere. The ultra low emission leakage rate is assured by the fine finish in the stem, the reduced diametrical clearances, and the stem straightness control special designed packing. Live load packing arrangement available upon request.
- ④ Integral backseat, designed to relieve back pressure on the stem packing when fully seated. Replacing stem packing under pressure is not recommended. Hard faced backseat available for severe service as customer requirements
- ⑤ Body to Bonnet Joint designed to apply a uniform load to the gasket or ring type joint to assure a leak proof seal.
- ⑥ Conical plug type disc, integrally guided to assure true alignment between disc and valve body. The disc design allows the disc and seat ring sealing surface to seat correctly without damage.
- ⑦ Integral seat ring
- ⑧ Two-piece arrangement gland flange and stem packing bushing for self-alignment to avoid stem damage.
- ⑨ Globe valves supplied handwheel operated as standard from 2" to 24".

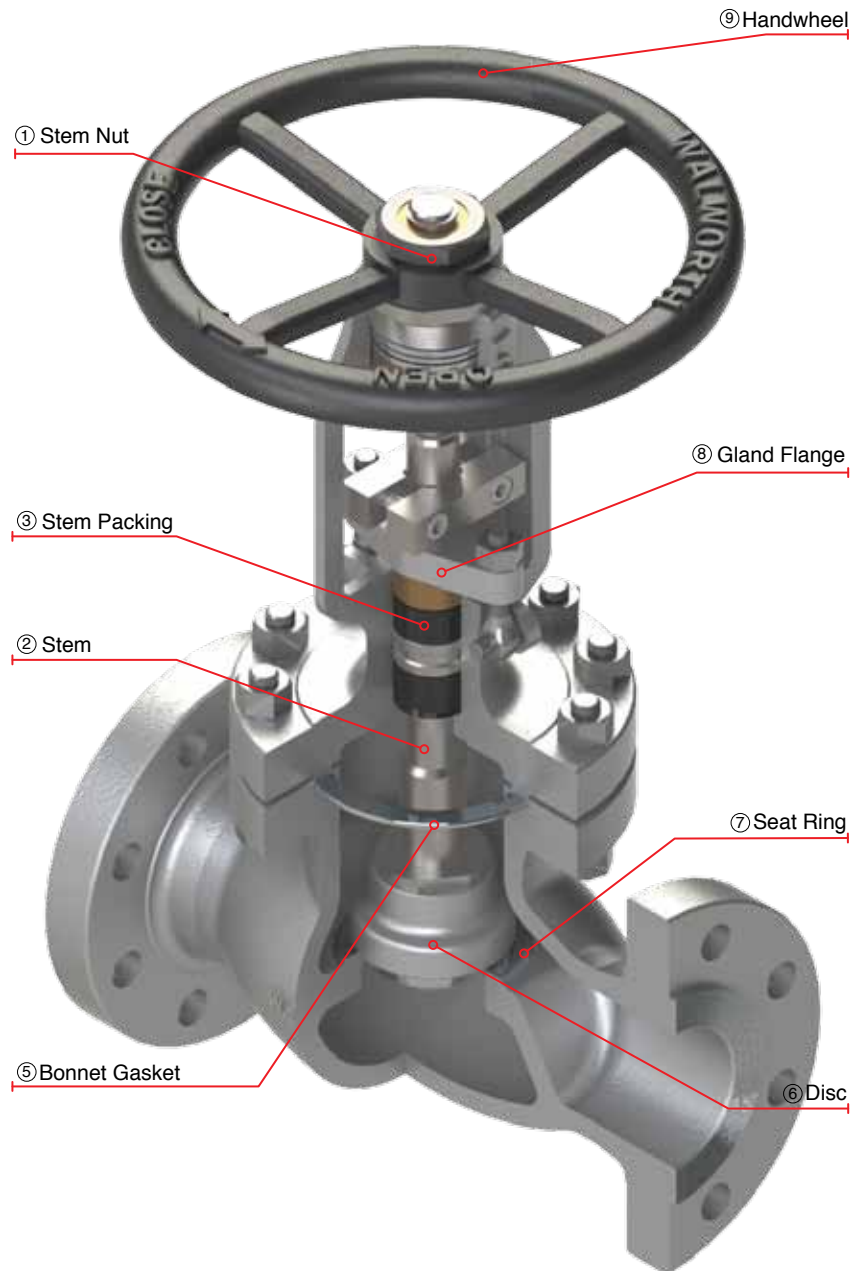

API-603 CAST STAINLESS STEEL & SPECIAL ALLOY GLOBE VALVES, CLASS 600 (INTEGRAL YOKE)

DESIGN FEATURES:

- Design in accordance with ASME B 16.34
- Rising stem and outside screw & yoke (OS&Y)
- Flange dimensions as per ASME B16.5
- End to end dimensions as per ASME B16.10
- WE dimensions as per ASME B 16.25
- Bonnet with bearings: 4" and larger
- Handwheel operated as standard

Catalog Figure No.	ID Plant Figure No.	Type of Ends
S5295RF	S5295F	Flanged Raised Face
S5295RTJ	S5295RJ	Ring Type Joint
S5295WE	S5295WE	Buttweld

Regular Bill of Materials

No.	Description	STANDARD MATERIAL
1	Body	ASTM A 351 GR CF8M
2	Bonnet	ASTM A 351 GR CF8M
3	Disc	ASTM A 351 GR CF8M + ST 6
*4	Seat Ring	Integral Seat Ring
5	Stem	ASTM A 476 Type 316
6	Stem Retainer	ASTM A 182 Type F316
7	Grease Fitting	Commercial
8	Stem Nut	UNS C95600
9	Stem Nut Retainer	ASTM A 182 GR F304
10	Position Indicator	ASTM A 182 GR F304
11	Bearings	Commercial
*12	Stem Seat	ASTM A 476 Gr 316 + ST 6
13	Eyebolt	ASTM A 193 GR B8
14	Eyebolt Nut	ASTM A 194 GR 8
15	Gland Flange	ASTM A 351 GR CF8M
16	Packing Bushing	ASTM A 476 Type 316
17	Eyebolt Pin	Alloy Steel
18	Stem Packing	Flexible graphite intermediate rings / Anti-extrusion rings on the top and bottom sides of the packing chamber
19	Lantern Ring	ASTM A 182 Type F316
20	Oppressor	Commercial
21	Bonnet Gasket / Ring Type Joint	Spiralitic Graphite + Stainless 316 / Stainless Steel 316
22	Bonnet Stud	ASTM A 193 GR B8
23	Bonnet Stud Nut	ASTM A 194 GR 8
24	Handwheel	As per WALWORTH design
25	Handwheel Nut	ASTM A 108 GR 1020
*26	Identification Plate	Stainless Steel

*Not shown

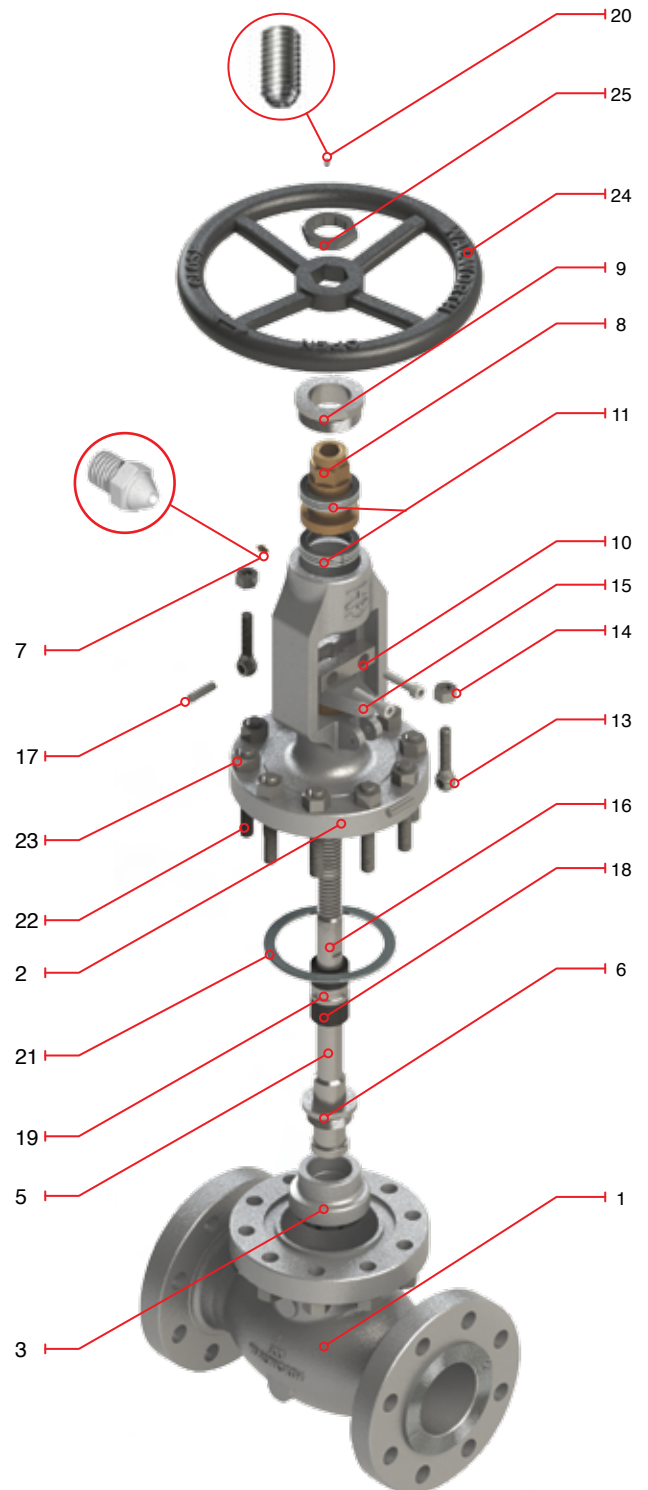

API-603 CAST STAINLESS STEEL & SPECIAL ALLOY GLOBE VALVES, CLASS 600 (INTEGRAL YOKE)

DESIGN FEATURES:

- Design in accordance with ASME B 16.34
- Rising stem and outside screw & yoke (OS&Y)
- Integral yoke
- Flange dimensions as per ASME B16.5
- End to end dimensions as per ASME B16.10
- WE dimensions as per ASME B 16.25
- Bonnet with bearings: 4" and larger
- Handwheel operated as standard



Catalog Figure No.	ID Plant Figure No.	Type of Ends
S5295RF	S5295F	Flanged Raised Face
S5295RTJ	S5295RJ	Ring Type Joint
S5295WE	S5295WE	Buttweld

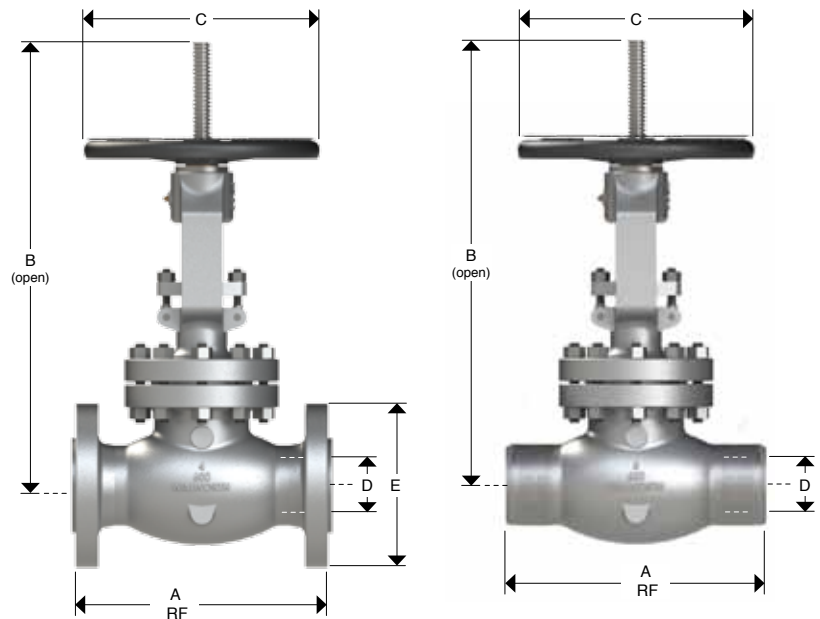

Dimensions and Weights

D Nominal Diameter	mm	50	65	80	100	150	200
	in	2	2.5	3	4	6	8
A (RF and WE)	mm	292	330	356	332	559	660
	in	11.5	13	14	17	22	26
B (Open)	mm	416	462	509	619	738	854
	in	16.4	18.2	20.0	24.4	29.4	33.6
C	mm	250	250	300	400	450	500
	in	9.8	9.8	11.8	15.7	17.7	19.7
E	mm	165	190	210	273	356	419
	in	6.5	7.5	8 ¼	10.75	14	16.5
Weight	Kg	30	42	54	95	208.5	321.8
S5295RF	lb	66.2	92.6	119.1	209.5	459.7	709.5
Weight	Kg	24	31	43	77	176.5	257.8
S5295WE	lb	52.9	68.4	94.8	169.8	389.2	568.3

For sizes and dimensions not shown, please contact our Sales Department.

API-603 CAST STAINLESS STEEL & SPECIAL ALLOY GLOBE VALVES, CLASS 600 (INDEPENDENT YOKE)

DESIGN FEATURES:

- Design in accordance with ASME B 16.34
- Rising stem and outside screw & yoke (OS&Y)
- Flange dimensions as per ASME B16.5
- End to end dimensions as per ASME B16.10
- WE dimensions as per ASME B 16.25
- Bonnet with bearings: 4" and larger
- Handwheel operated as standard

Catalog Figure No.	ID Plant Figure No.	Type of Ends
S5295RF	S5295F	Flanged Raised Face
S5295RTJ	S5295RJ	Ring Type Joint
S5295WE	S5295WE	Buttweld

Regular Bill of Materials

No.	Description	STANDARD MATERIAL
1	Body	ASTM A 351 GR CF8M
2	Bonnet	ASTM A 351 GR CF8M
3	Disc	ASTM A 351 Gr CF8M + ST 6
4	Yoke	ASTM A 351 GR CF8M
*5	Seat Ring	Integral Seat Ring
6	Stem	ASTM A 476 Type 316
7	Stem Retainer	ASTM A 182 Type F316
8	Grease Fitting	Commercial
9	Stem Nut	UNS C95600
10	Stem Nut Retainer	ASTM A 182 GR F304
11	Position Indicator	ASTM A 182 GR F304
12	Bearings	Commercial
*13	Stem Seat	ASTM A 476 Gr 316 + ST 6
14	Eyebolt	ASTM A 193 GR B8
15	Eyebolt Nut	ASTM A 194 GR 8
16	Gland Flange	ASTM A 351 GR CF8M
*17	Packing Bushing	ASTM A 476 Type 316
18	Eyebolt Pin	Alloy Steel
19	Stem Packing	Flexible graphite intermediate rings / Anti-extrusion rings on the top and bottom sides of the packing chamber
20	Lantern Ring	ASTM A 182 Type F316
21	Opressor	Commercial
22	Bonnet Gasket / Ring Type Joint	Spirallic Graphite + Stainless 316 / Stainless Steel 316
23	Yoke Bolt	ASTM A 193 GR B8
24	Yoke Bolt Nut	ASTM A 194 GR 8
25	Bonnet Stud	ASTM A 193 GR B8
26	Bonnet Stud Nut	ASTM A 194 GR 8
27	Handwheel	As per WALWORTH design
28	Handwheel Nut	ASTM A 108 GR 1020
*29	Identification Plate	Stainless Steel

*Not shown

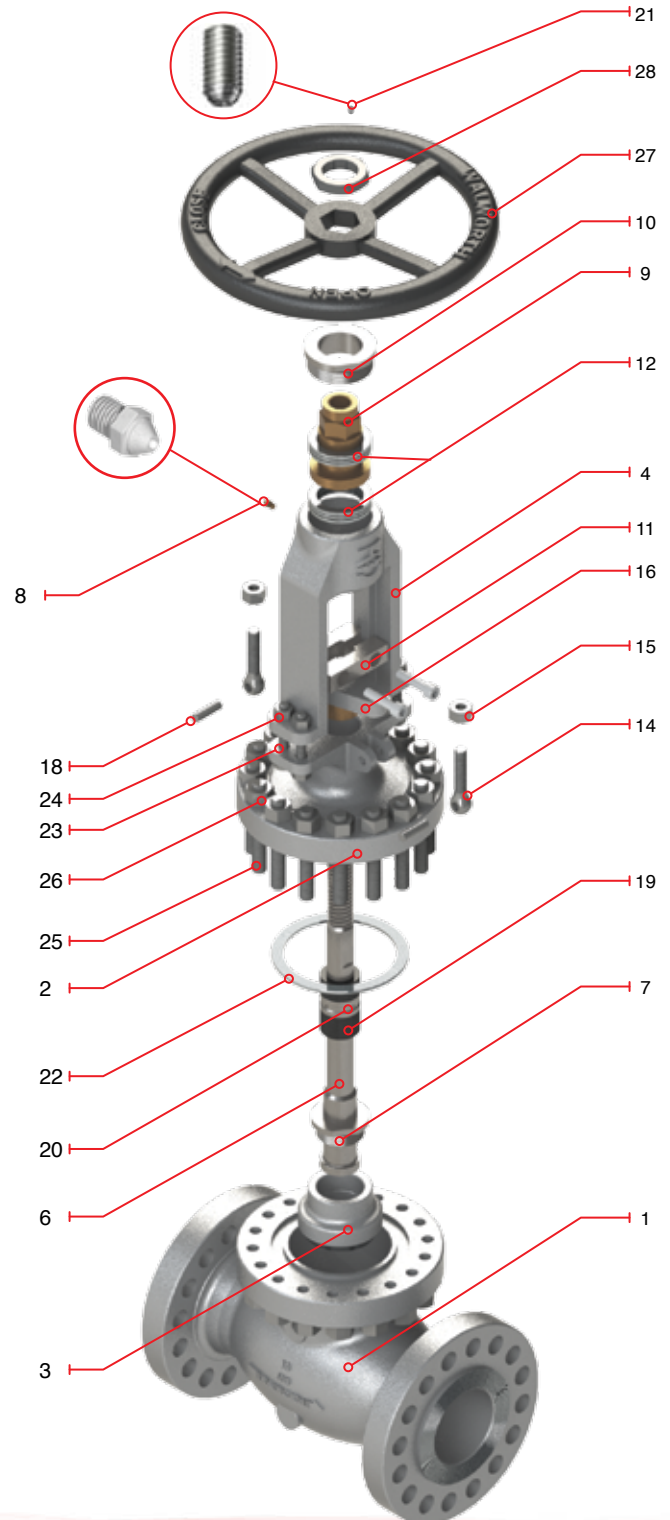

API-603 CAST STAINLESS STEEL & SPECIAL ALLOY GLOBE VALVES, CLASS 600 (INDEPENDENT YOKE)

DESIGN FEATURES:

- Design in accordance with ASME B 16.34
- Rising stem and outside screw & yoke (OS&Y)
- Flange dimensions as per ASME B16.5
- End to end dimensions as per ASME B16.10
- WE dimensions as per ASME B 16.25
- Bonnet with bearings
- Handwheel operated as standard

Catalog Figure No.	ID Plant Figure No.	Type of Ends
S5295RF	S5295F	Flanged Raised Face
S5295RTJ	S5295RJ	Ring Type Joint
S5295WE	S5295WE	Buttweld

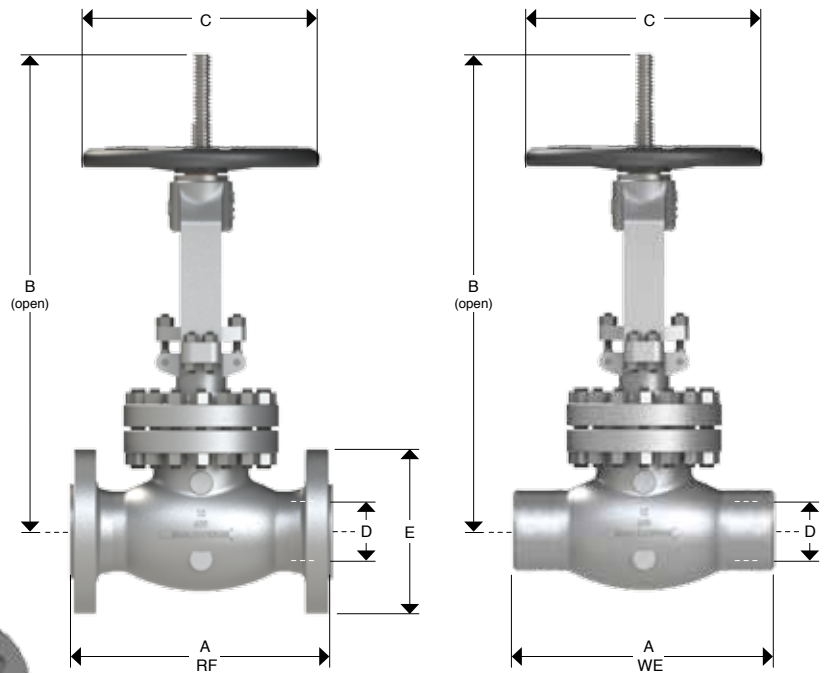

Dimensions and Weights

D Nominal Diameter	mm	250	300
	in	10	12
A (RF and WE)	mm	787	838
	in	31	33
B (Open)	mm	935	1015
	in	36.8	40
C	mm	550	600
	in	21.7	23.6
E	mm	508	559
	in	20	22
Weight S5295RF	Kg	552.8	895.5
	lb	1218.8	1974.6
Weight S5295WE	Kg	484.75	752.5
	lb	1068.9	1659.3

For sizes and dimensions not shown, please contact our Sales Department.

API-603 CAST STAINLESS STEEL & SPECIAL ALLOY SWING CHECK VALVES, CLASS 150 CAST STEEL SWING CHECK VALVES

DESIGN FEATURES

- Swing check valves design in accordance with API-603 & ASME B16.34
 - Swing check valves for cryogenic service in accordance with BS-6364
 - Damper & counter weight options
 - Drain connections as per Customer request.
 - Low fugitive emissions control
 - NACE service either MR-01-75 or MR-01-03
 - Test in accordance with API-598
- ① Body to cover joint designed to apply a uniform load to the gasket to assure a leak proof seal.
 - ② Disc to hanger connection allows the disc controlled movement independent of the hanger to assure proper disc alignment with the seat at closure.
 - ③ The connection is secured by a welded disc nut to prevent disassembly due to vibration and closure impact.
 - ④ Stellite seat ring provides increased resistance to wear abrasion and erosion of the sealing surface.
 - ⑤ From 4" and up, WALWORTH check valves have cover lug for easy installation.

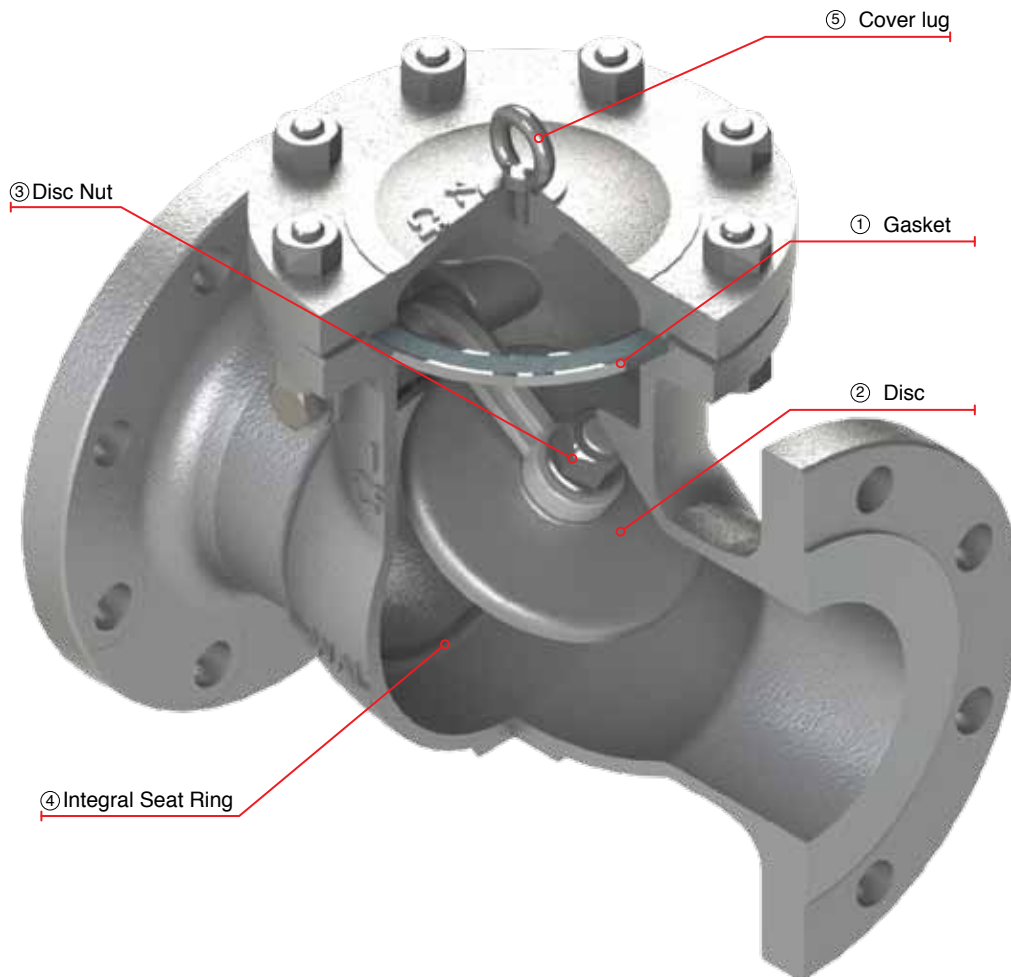

API-603 CAST STAINLESS STEEL & SPECIAL ALLOY SWING CHECK VALVES, CLASS 150

DESIGN FEATURES:

- Design in accordance with API-603 & ASME B16.34
- Flange dimensions as per ASME B16.5
- End to end dimensions as per ASME B16.10
- WE dimensions as per ASME B 16.25

Catalog Figure No.	ID Plant Figure No.	Type of Ends
S5341RF	S5341F	Flanged Raised Face
S5341RTJ	S5341RJ	Ring Type Joint
S5341WE	S5341WE	Buttweld

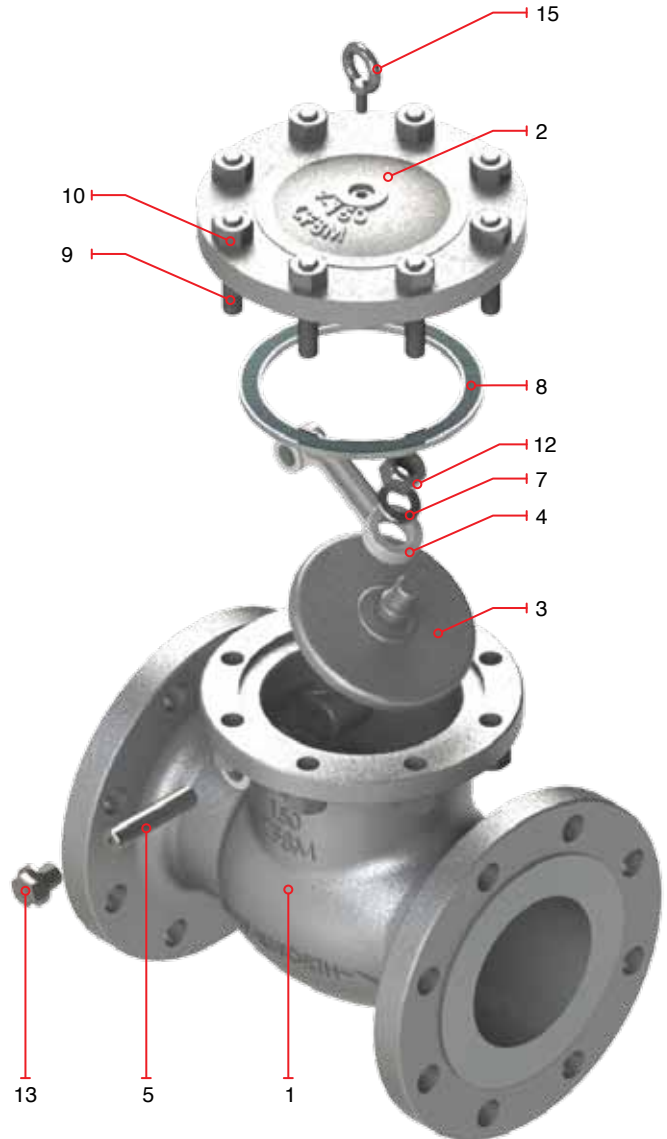

Regular Bill of Materials

5No.	Description	STANDARD MATERIAL
1	Body	ASTM A 351 GR CF8M
2	Cover	ASTM A 351 GR CF8M
3	Disc	ASTM A 351 GR CF8M + ST 6
4	Hanger	ASTM A 351 GR CF8M
5	Shaft	ASTM A 182 Type F316
*6	Shaft Washer	ASTM A 182 Type F316
7	Disc Washer	ASTM A 182 Type F316
8	Gasket	Spiral Stainless 316/Graphite
9	Stud	ASTM A 193 GR B8
10	Stud Nut	ASTM A 194 GR 8
*11	Set Screw	ASTM A 479 Type 316
12	Disc Nut	ASTM A 194 GR 8
13	Body Plug	ASTM A 182 Type F316
*14	Identification Plate	Stainless Steel
**15	Cover lug	Commercial Steel

*Not Shown

**Only from 4" and up

API-603 CAST STAINLESS STEEL & SPECIAL ALLOY SWING CHECK VALVES, CLASS 150



DESIGN FEATURES:

- Design in accordance with API-603 & ASME B16.34
- Flange dimensions as per ASME B16.5
- End to end dimensions as per ASME B16.10
- WE dimensions as per ASME B 16.25

Catalog Figure No.	ID Plant Figure No.	Type of Ends
S5341RF	S5341F	Flanged Raised Face
S5341RTJ	S5341RJ	Ring Type Joint
S5341WE	S5341WE	Buttweld

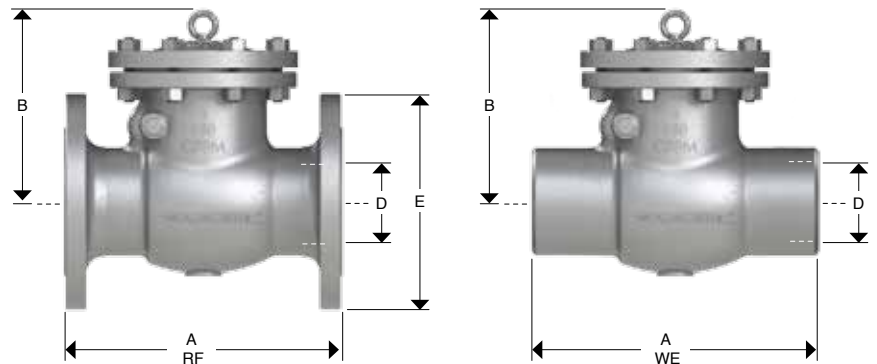

Dimensions and Weights

D Nominal Diameter	mm	51	64	76	102	152	203	254	305	356	406	457	508	610
	in	2	2.5	3	4	6	8	10	12	14	16	18	20	24
A (RF and WE)	mm	203	216	241	292	406	495	622	698	787	914	978	978	1295
	in	8	8.5	9.5	11.5	16	19.5	24.5	27.5	31	36	38.5	38.5	51
B	mm	123	135	150	205	253	305	370	439	493	598	605	662	702
	in	4.8	5.3	5.9	8.1	10.0	12.0	14.6	17.3	19.4	21.6	23.8	26.1	27.6
E	mm	152	178	191	229	279	343	406	483	533	597	635	699	813
	in	6	7	7.5	9	11	13.5	16	19	21	23.5	25	27.5	32
Weight S5341RF	Kg	8.8	13	18	30	50	91	135	210	349	459	540	826	1044
	lb	19.4	28.7	39.7	66.2	110.3	200.7	297.7	463.1	769.5	1012.1	1190.7	1821.3	2302.0
Weight S5341WE	Kg	6.8	11	14	26	45	71	89	140	279	367	432	661	835
	lb	15.0	24.3	30.9	57.3	99.2	156.6	196.2	308.7	615.2	809.2	952.6	1457.5	1841.2

PCR = Per customer request

API-603 CAST STAINLESS STEEL & SPECIAL ALLOY

SWING CHECK VALVES, CLASS 300 CAST STEEL SWING CHECK VALVES

DESIGN FEATURES

- Swing check valves design in accordance with API-603 & ASME B16.34.
 - Swing check valves for cryogenic service in accordance with BS-6364.
 - Damper & counter weight options.
 - Drain connections as per Customer request.
 - Low fugitive emissions control.
 - NACE service either MR-01-75 or MR-01-03.
 - Test in accordance with API-598.
- ① Body to cover joint designed to apply a uniform load to the gasket to assure a leak proof seal.
 - ② Disc to hanger connection allows the disc a controlled movement independent of the hanger to assure proper disc alignment with the seat at closure.
 - ③ The connection is secured by a welded disc nut to prevent disassembly due to vibration and closure impact.
 - ④ Stellite seat ring provides increased resistance to wear abrasion and erosion of the sealing surface.
 - ⑤ From 4" and up, WALWORTH check valves have cover lug for easy installation.

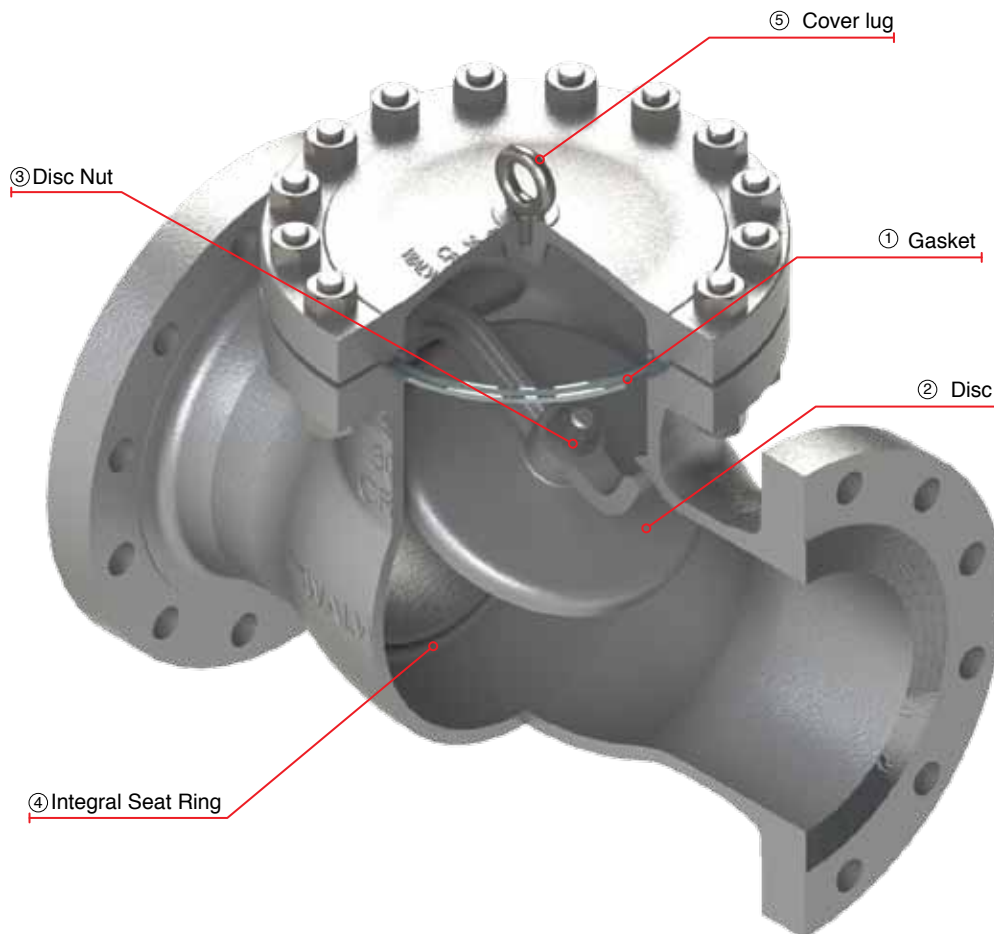

API-603 CAST STAINLESS STEEL & SPECIAL ALLOY SWING CHECK VALVES, CLASS 300

DESIGN FEATURES:

- Design in accordance with API-603 & ASME B16.34
- Flange dimensions as per ASME B16.5
- End to end dimensions as per ASME B16.10
- WE dimensions as per ASME B 16.25

Catalog Figure No.	ID Plant Figure No.	Type of Ends
S5344RF	S5344F	Flanged Raised Face
S5344RTJ	S5344RJ	Ring Type Joint
S5344WE	S5344WE	Buttweld

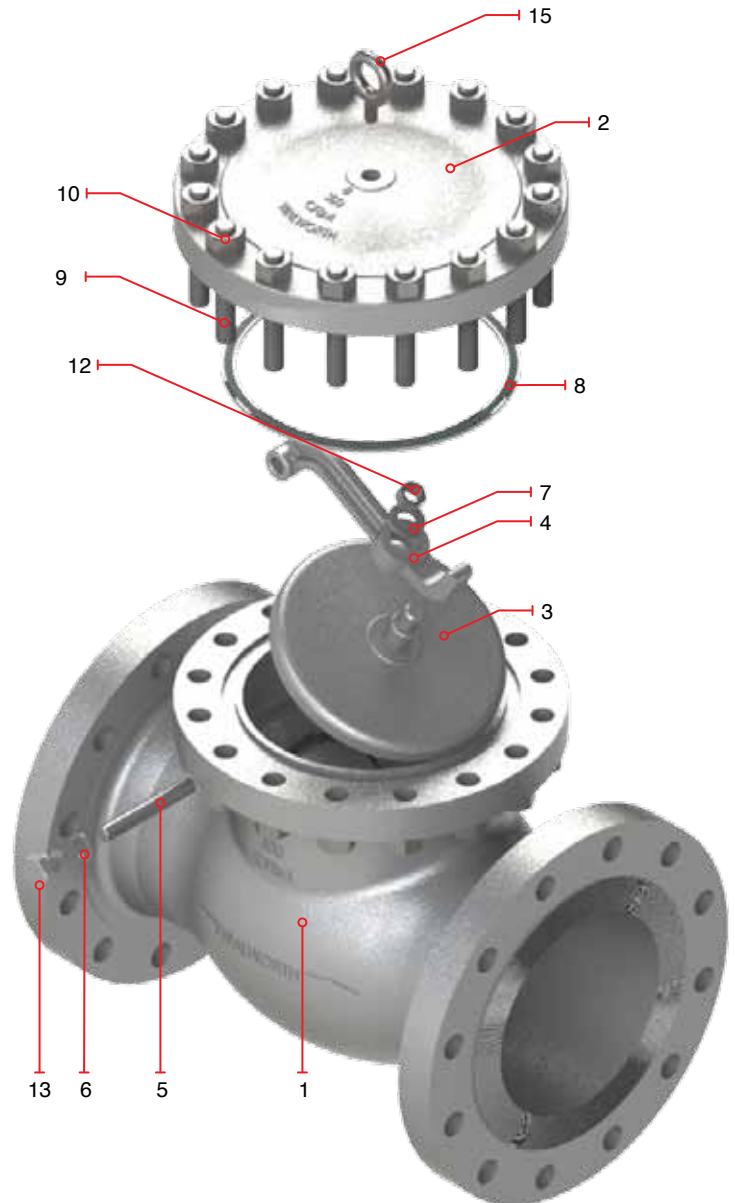

Regular Bill of Materials

No.	Description	STANDARD MATERIAL
1	Body	ASTM A 351 GR CF8M
2	Cover	ASTM A 351 GR CF8M
3	Disc	ASTM A 351 GR CF8M + ST 6
4	Hanger	ASTM A 351 GR CF8M
5	Shaft	ASTM A 182 Type F316
6	Shaft Washer	ASTM A 182 Type F316
7	Disc Washer	ASTM A 182 Type F316
8	Gasket	Spiral Stainless 316/Graphite
9	Stud	ASTM A 193 GR B8
10	Stud Nut	ASTM A 194 GR 8
*11	Set Screw	ASTM A 479 Type 316
12	Disc Nut	ASTM A 194 GR 8
13	Body Plug	ASTM A 182 Type F316
*14	Identification Plate	Stainless Steel
15	Cover lug	Commercial Steel

*Not Shown

**Only from 4" and up

API-603 CAST STAINLESS STEEL & SPECIAL ALLOY SWING CHECK VALVES, CLASS 300



DESIGN FEATURES:

- Design in accordance with API-603 & ASME B16.34
- Flange dimensions as per ASME B16.5
- End to end dimensions as per ASME B16.10
- WE dimensions as per ASME B 16.25

Catalog Figure No.	ID Plant Figure No.	Type of Ends
S5344RF	S5344F	Flanged Raised Face
S5344RTJ	S5344RJ	Ring Type Joint
S5344WE	S5344WE	Buttweld

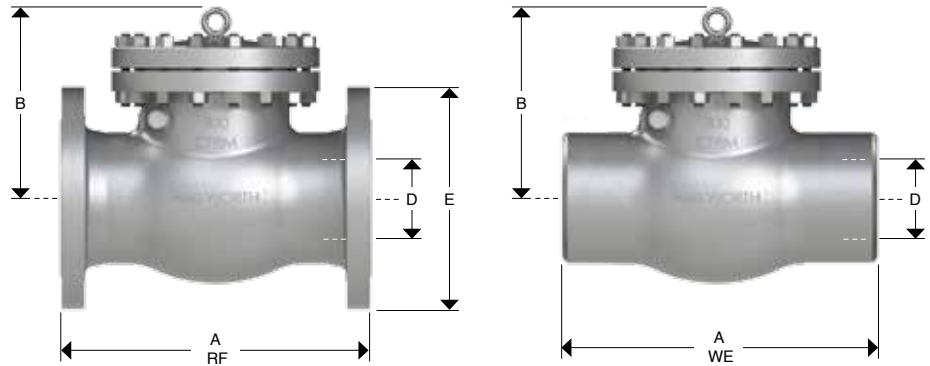

Dimensions and Weights

D Nominal Diameter	mm	50	65	80	100	150	200	250	300	350	400	450	500	610
	in	2	2.5	3	4	6	8	10	12	14	16	18	20	24
A (RF and WE)	mm	267	292	318	356	445	533	622	711	838	684	978	1016	1346
	in	10.5	11.5	12.5	14	17.5	21	24.5	28	33	34	38.5	40	53
B	mm	140	165	174	231	286	326	375	436	476	610	660	690	767
	in	5.5	6.5	6.9	9.1	11.3	12.8	14.8	17.2	18.7	24	26	27.2	30.2
E	mm	165	191	210	254	318	381	445	521	584	648	711	775	914
	in	6.5	7.5	8 ¼	10	12.5	15	17.5	20.5	23	25.5	28	30.5	36
Weight S5344RF	Kg	16	23	32	50	95	150	229	360	576	691	891	1022	1962
	lb	35.3	50.7	70.6	110.3	209.5	330.8	504.9	793.8	1270.1	1523.7	1964.7	2253.5	4326.2
Weight S5344WE	Kg	13	21	28	45	61	105	176	305	518	630	812	931	1788
	lb	28.7	46.3	61.7	99.2	134.5	231.5	388.1	672.5	1142.2	1389.2	1790.5	2052.9	3942.5

PCR = Per customer request

API-603 CAST STAINLESS STEEL & SPECIAL ALLOY SWING CHECK VALVES, CLASS 600 CAST STEEL SWING CHECK VALVES

DESIGN FEATURES

- Swing check valves design in accordance with API-603 & ASME B16.34.
 - Swing check valves for cryogenic service in accordance with BS-6364.
 - Damper & counter weight options.
 - Drain connections as per Customer request.
 - Low fugitive emissions control.
 - NACE service either MR-01-75 or MR-01-03.
 - Test in accordance with API-598.
- ① Body to cover joint designed to apply a uniform load to the gasket to assure a leak proof seal.
 - ② Disc to hanger connection allows the disc a controlled movement independent of the hanger to assure proper disc alignment with the seat at closure.
 - ③ The connection is secured by a welded disc nut to prevent disassembly due to vibration and closure impact.
 - ④ Stellite seat ring provides increased resistance to wear abrasion and erosion of the sealing surface.
 - ⑤ From 4" and up, WALWORTH check valves have cover lug for easy installation.

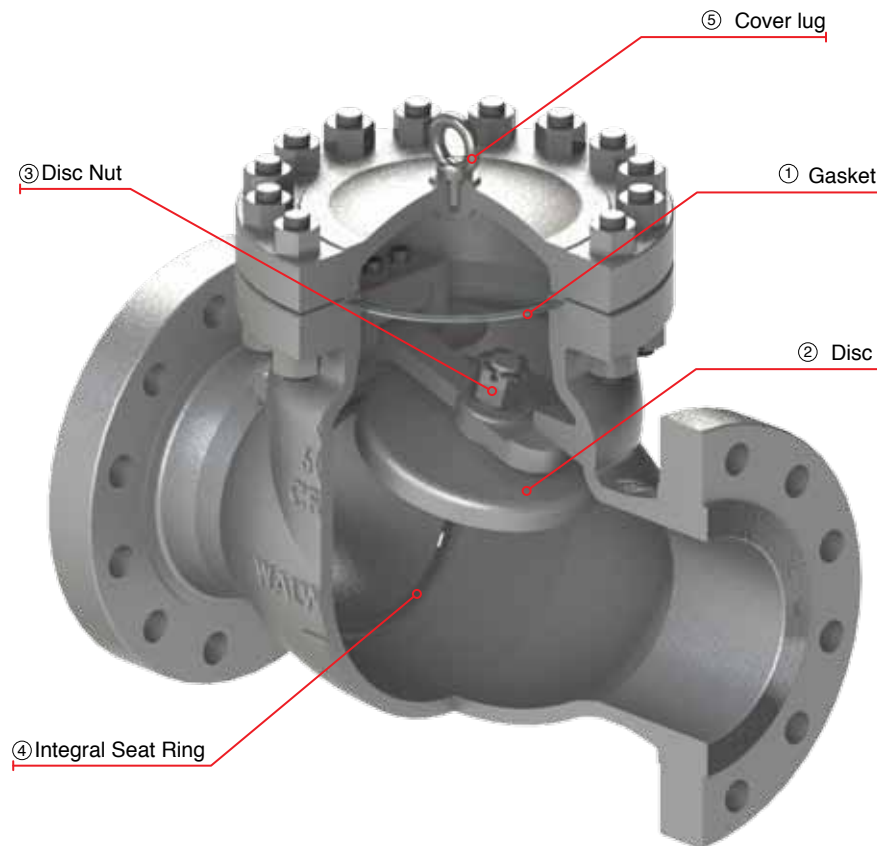

API-603 CAST STAINLESS STEEL & SPECIAL ALLOY SWING CHECK VALVES, CLASS 600

DESIGN FEATURES:

- Design in accordance with API-603 & ASME B16.34
- Flange dimensions as per ASME B16.5
- End to end dimensions as per ASME B16.10
- WE dimensions as per ASME B 16.25

Catalog Figure No.	ID Plant Figure No.	Type of Ends
S5350RF	S5350F	Flanged Raised Face
S5350RTJ	S5350RJ	Ring Type Joint
S5350WE	S5350WE	Buttweld

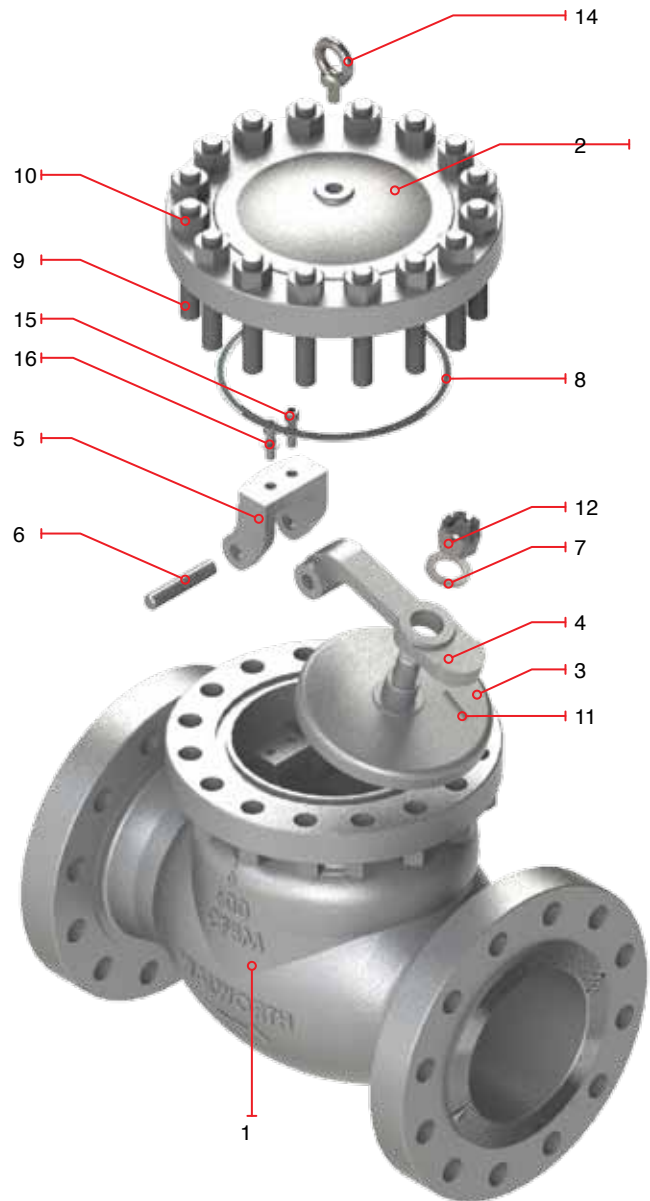

Regular Bill of Materials

No.	Description	STANDARD MATERIAL
1	Body	ASTM A 351 GR CF8M
2	Cover	ASTM A 351 GR CF8M
3	Disc	ASTM A 351 GR CF8M + ST 6
4	Hanger	ASTM A 351 GR CF8M
5	Hanger Support	ASTM A 351 GR CF8M
6	Shaft	ASTM A 182 Type F316
7	Disc Washer	ASTM A 182 Type F316
8	Gasket	Spiral Stainless 316/Graphite
9	Stud	ASTM A 193 GR B8
10	Stud Nut	ASTM A 194 GR 8
11	Set Screw	ASTM A 479 Type 316
12	Disc Nut	ASTM A 194 GR 8
*13	Identification Plate	Stainless Steel
**14	Cover Lug	Commercial Steel
15	Hanger Support Screw	ASTM A193 GR B8
16	Hanger Support Washer	ASTM A351 GR F316

*Not Shown

**Only from 4" and up

API-603 CAST STAINLESS STEEL & SPECIAL ALLOY SWING CHECK VALVES, CLASS 600



DESIGN FEATURES:

- Design in accordance with API-603 & ASME B16.34
- Flange dimensions as per ASME B16.5
- End to end dimensions as per ASME B16.10
- WE dimensions as per ASME B 16.25

Catalog Figure No.	ID Plant Figure No.	Type of Ends
S5350RF	S5350F	Flanged Raised Face
S5350RTJ	S5350RJ	Ring Type Joint
S5350WE	S5350WE	Buttweld

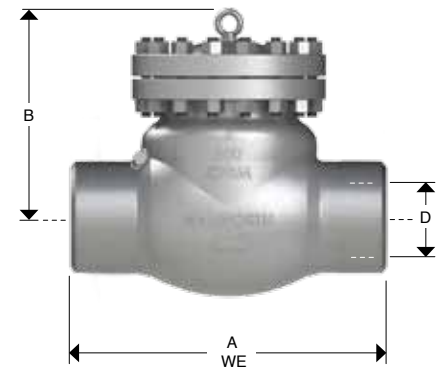
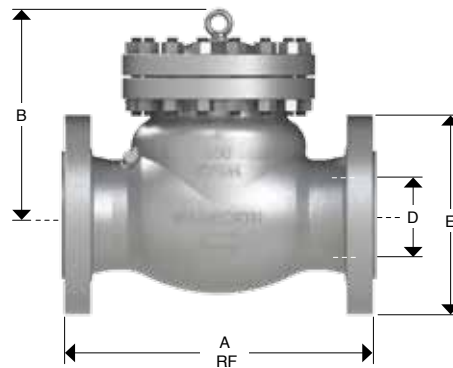

Dimensions and Weights

D Nominal Diameter	mm	50	65	80	100	150	200	250	300
	in	2	2.5	3	4	6	8	10	12
A (RF and WE)	mm	292	330	356	432	559	660	787	838
	in	11.5	13	14	17	22	26	31	33
B	mm	158	177	182	241	335	432.5	502	565
	in	6.2	7.0	7.2	9.5	13.2	17	19.8	22.2
E	mm	165	191	210	273	356	419	508	559
	in	6.5	7.5	8 ¼	10.75	14	16.5	20	22
Weight S5350RF	Kg	20	28	40	82	170	271	477	609
	lb	44.1	61.7	88.2	180.8	374.9	597.6	1051.8	1342.8
Weight S5350WE	Kg	16	22	33	69	144	225	409	517
	lb	35.3	48.5	72.8	152.1	317.5	496.1	901.8	1140.0

PCR = Per customer request

TECHNICAL INFORMATION

FLEXIBLE WEDGE DESIGNS

- Provides resistance to possible wedge/seat sticking from high temperature to low temperature fluctuations by compensating for the resulting small body/seat movement.
- Facilitates seating and sealing and assures a long wear life.
- Susceptible to build-up when used with fluids having high solids content.



RELIEVE PRESSURE ACCESSORIES

Excessive pressure trapped in the body center cavity of standard gate valves can produce overpressure in this area which makes opening the valve difficult. An equalizer system may release overpressure to another specific pipe system. In the case of globe or check valves, these pressure release fixtures are used also to bypass fluid from the center of the body to another specific area.

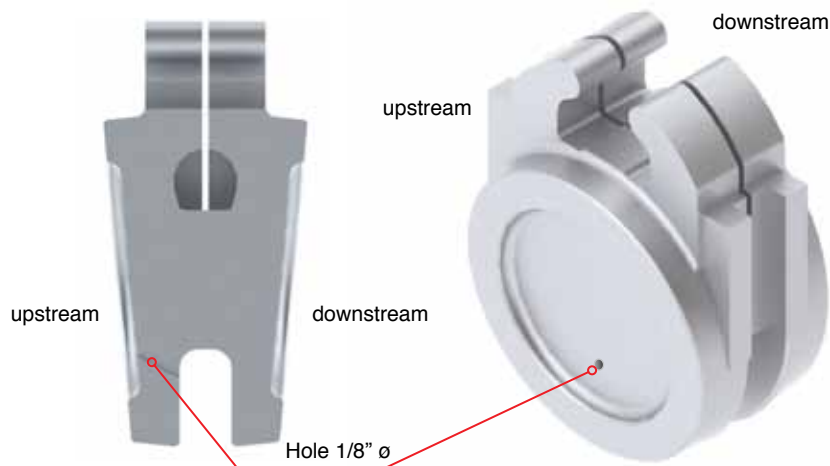

Equalizer hole.- A hole drilled of 1/8" in diameter or a groove 1/8" wide and deep is located in the upstream seat area of the disc.

TECHNICAL INFORMATION

LANTERN RING-CONDENSING CHAMBER

WALWORTH API 603 valves can be provided with a stem packing/lantern ring combination of packing above and below the lantern ring to provide the ability to condense/vent material being processed.

The system can be utilized to lubricate the packing or to drain/purge the stem area to a leakage recovery system when liquids/gasses cannot be released to the atmosphere.

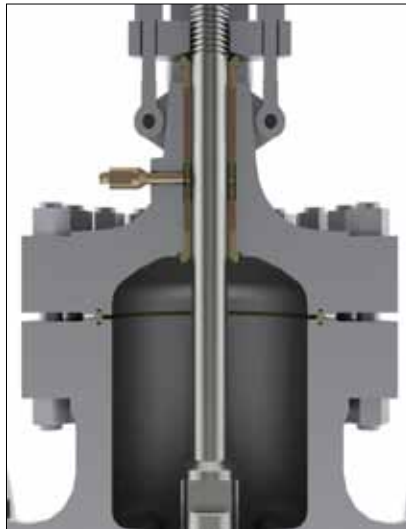

NACE SERVICE VALVES

The National Association of Corrosion Engineers (NACE) establishes standards for materials resistant to Sulfide Stress Cracking (SSC) to be used in hydrogen sulfide (H₂S) bearing hydrocarbon service.

NACE standard MR0175 defines a sulfide stress cracking region based on the relationship of H₂S present to the total operating pressure.

This must be considered when specifying valves for service where H₂S is present, as proper selection of materials is the customer's responsibility.

Sulfide stress cracking in materials not suitable for H₂S service can result in a sudden failure, with damage to equipment and harm to personnel.

Important considerations when specifying NACE service are:

1. Hydrogen ion concentration (Ph).
2. Concentration and total pressure of the hydrogen sulfide (H₂S).
3. Concentration of water, carbon dioxide (CO₂) and chlorides.
4. Service temperature.

The customer can select valves made of alloy steel material with controlled hardness and/or a stainless steel material, depending on the severity of the fluid. Valves having a body/bonnet with a controlled hardness of Rc 22 and studs/nuts of B7M/2HM can be combined with a customer's selected trim and manufactured to meet NACE MR0175 requirements.

TECHNICAL INFORMATION

STEM PACKING

WALWORTH valves are designed, manufactured and tested to allow a maximum of 50 ppm voc (volatile organic compounds) of fugitive emissions as a standard. This applies to all gate and globe valves, without a requirement for a “special order”.

WALWORTH stem packing design consists of an arrangement of inner high and low density sealing rings and outer anti-extrusion rings which are reinforced with SS316 wire. This stem packing includes a passive corrosion inhibitor.

The long term low emission stem sealing ability of WALWORTH packing is enhanced by reduced diametral clearances and close control of stem straightness and packing sealing surface finish.

WALWORTH can also provide gate and globe valves with a stem packing live loading system for installations requiring frequent valve operation and/or having large variations in temperature/pressure, or where it is desirable to eliminate the need for occasional adjustment of the packing to compensate for the variations in operation. Live loading will provide a constant compression against the packing to maintain the optimum seal over a long period of time and variations in the operating conditions.

WALWORTH can also supply valves with stem packing of different types and materials to meet customer requirements.

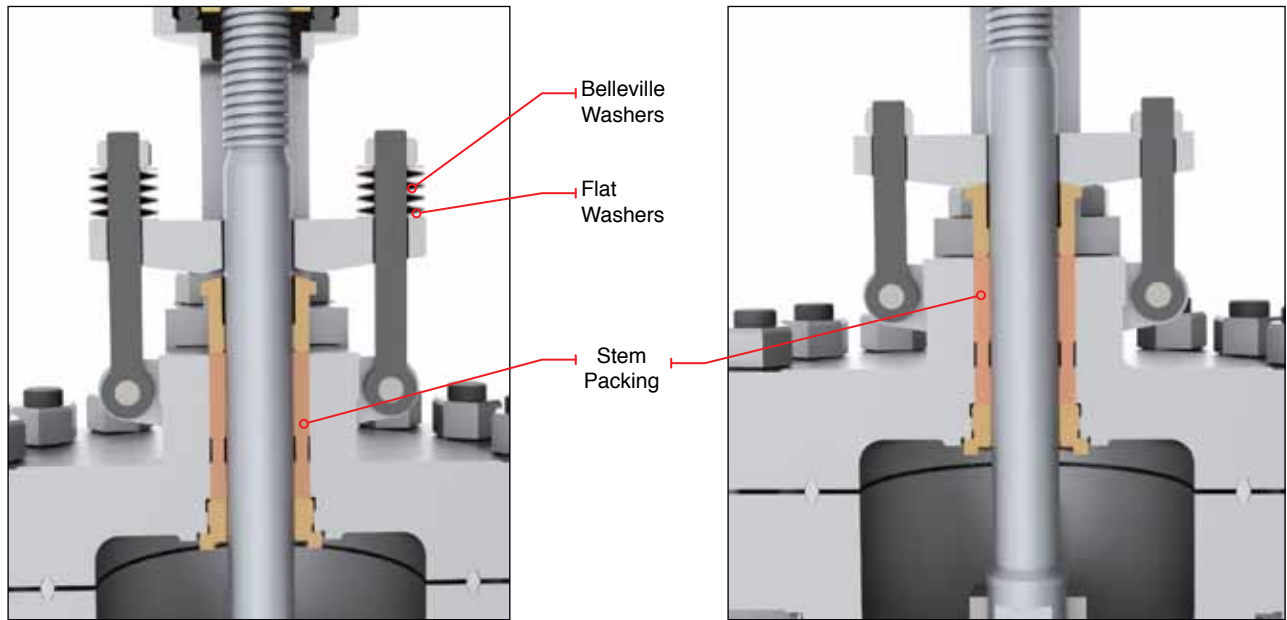

**Live Loading Stem
Packing System**

**Standard Stem Packing
System**

TECHNICAL INFORMATION

BODY AND BONNET JOINT SEAL GASKETS

WALWORTH API-603 standard valves are supplied with the types of body/bonnet gaskets shown in the table.

For Special service conditions WALWORTH valves can be manufactured in special materials, with special shapes in joints to comply the specific customer requirements.

VALVE	CLASS		
	150	300	600
GATE	1	2	2 or 3
GLOBE	1	2	2 or 3
CHECK	1	2	2 or 3

FLAT GASKET



1.- FLAT GASKET: Graphite with 316 Stainless Steel Core



SPIROTALLIC GASKET



2.- SPIROTALLIC GASKET: Stainless Steel / Graphite Filled



RING GASKET



3.- RING TYPE JOINT: Oval or Octagonal shape, Soft Stainless Steel



TECHNICAL INFORMATION

TYPES OF END CONNECTIONS

WALWORTH API-603 valves can be supplied with flanged ends in raised face, flat face or ring joint type as well as in weld ends (butt weld). They can also be supplied with combined ends, such as flanged by weld, in accordance with the customer's requirements.

The butt weld ends in standard valves are machined in accordance with ASME B 16.25 and are supplied to meet the following pipe schedules:

Valve Pressure Class	Weld End Pipe Schedule*
150/300	Schedule 40 – 2" to 10" Standard Wall – 12" to 24"
600	Schedule 80

* Other schedules available upon request

The customer must clearly specify the pipe wall thickness and type of pipe to be welded to the valves for schedules different from the above.

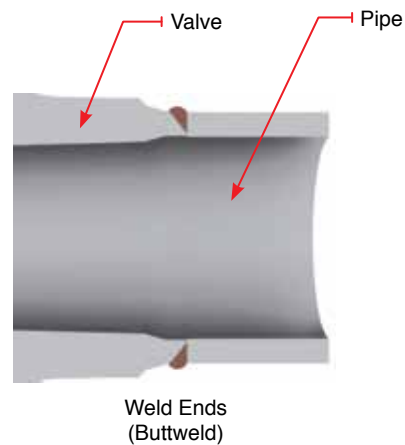
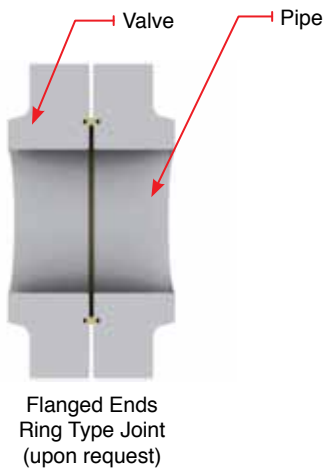
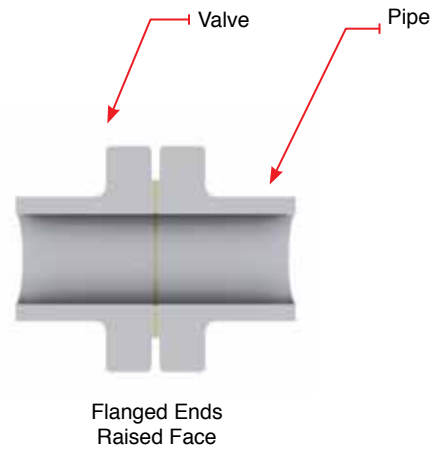
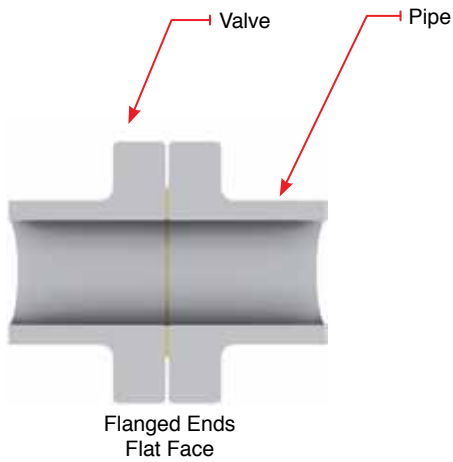

TECHNICAL INFORMATION

TYPE OF OPERATIONS

The WALWORTH standard cast steel product line includes many different valves designed to meet most applications.

Special adaptations can be made to meet specific customer requirements. Valves can be supplied with manual handwheel/gear operation, chain wheel, as well as electric, pneumatic and hydraulic actuators.

This makes it possible for WALWORTH to furnish valves adapted to our customer's special needs, such as controlled opening/closing and remote installation.

Valves can also be supplied with a bypass, drain or vent connection, stem extension, position indicators, floor stand mounting as well as a lever and weight system for swing check valves.

Gear Operators

A manual gear operator is designed with a bevel gear and pinion ratio sized to transmit the required opening/closing torque with normal operator effort on the handwheel. They can be supplied as waterproof units and/or for underground installation with a square operating nut.



Chain Wheel Operation

Chain wheels are designed for operating valves installed in remote or inaccessible locations. They can be furnished with roller guides to prevent the chain from jumping off the wheel. Impact type chain wheels are also available to assist in unseating a tightly closed valve.



Actuators

Valves can be furnished with either electric, pneumatic or hydraulic actuators. The actuators can be furnished as either waterproof and/or explosion proof. The customer must specify such things as open-close speed, maximum differential pressure, service temperature, type of voltage-phase-frequency, air or gas pressure for pneumatic actuators, and flow characteristics for hydraulic actuators to be assured of correct performance.



TECHNICAL INFORMATION

ACCESSORIES

Bypass, Drain and Vent Connections

A bypass line can be furnished with WALWORTH API-603 valves for equalizing pressure around the main valve or for warming up the line before opening the main valve. Drain connections are normally located in the valve body to drain the valve when internal inspection or maintenance is required.

A vent connection can be located in the valve bonnet to relieve an over-pressure that could occur due to an expansion of trapped liquid. MSS SP-45 lists the standard locations and connection sizes for gate, globe and check valves.



Nominal Size of Valve	2" to 4"	6" to 8"	10" and larger
Size of Bypass-Drain-Vent	1/2"	3/4"	1"

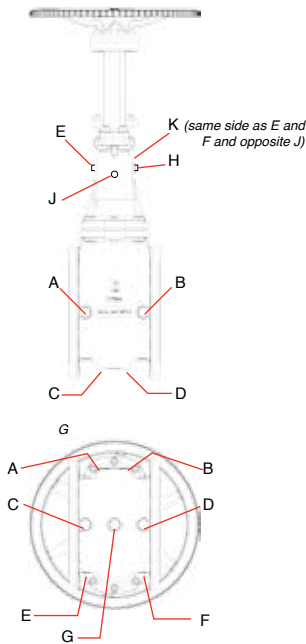

Gate Valve

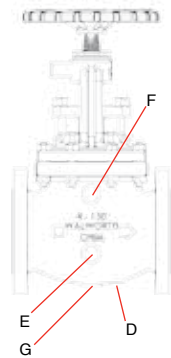
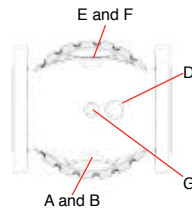

Globe Valve

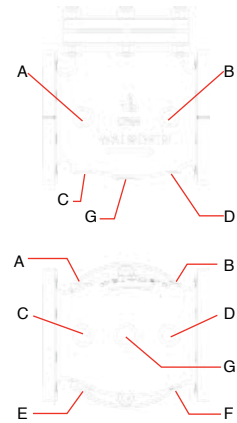
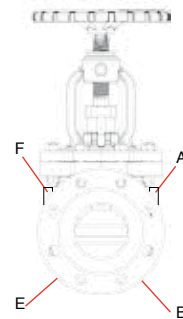

Check Valve

Bosses and drain connection positions in accordance with MSS-SP-45 & ASME B16.34 Standards

TECHNICAL INFORMATION

ACCESSORIES

Stem Extensions and Floor Stands

Stem extensions and floor stands are used to facilitate operation of a valve installed either underground, in a vault, or on a platform. These arrangements are available for either handwheel,

chainwheel or gear operation. The distance from the center of the valve port to the top of the stem or center line of the gear operator must be specified for stem extensions. The distance from the center of the valve port to the floor level must be specified for a floor stand mounting.

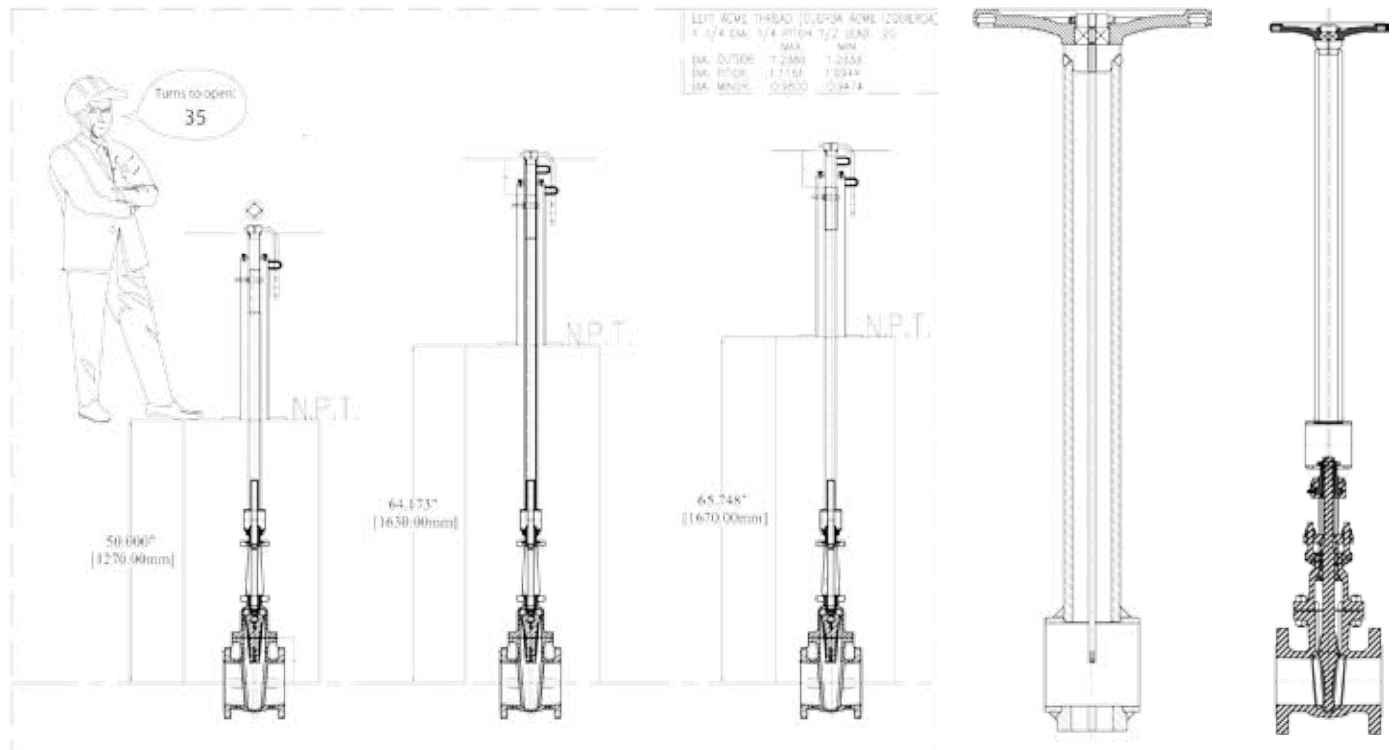

Lever and Counter Weight

A lever and counter weight is used on a swing check valve to help control the valve opening under variable flow conditions to prevent disc flutter, and also to assist/control the disc closing under a rapid flow reversal condition to prevent disc/seal damage. A spring can also be used with a lever to provide a more rapid closing, as can a dash pot or snubber to soften the closing seat contact during a flow reversal.



PRESSURE-TEMPERATURE RATINGS

CAST STEEL ASTM A 351 GR CF8

Temperature		Maximum allowable non-shock working pressure in PSIG by class		
°F	°C	150	300	600
-20 to 100	-29 to 38	275	720	1440
200	93	230	600	1200
300	149	205	540	1075
400	204	190	495	995
500	260	170	465	9320
600	316	140	440	885
650	343	125	430	865
700	371	110	420	845
750	399	95	415	825
800	427	80	405	710
850	454	65	395	790
900	482	50	390	780
950	510	35	380	765
1000	538	20	355	710
1050	566	20(a)	325	650
1100	593	20(a)	255	515
1150	621	20(a)	205	410
1200	649	20(a)	165	330
1250	677	20(a)	135	265
1300	704	20(a)	115	225
1350	732	20(a)	95	185
1400	760	20(a)	75	150
1450	788	20(a)	60	115
1500	816	15(a)	40	85

Note:

* At temperatures over 1,000°F, use only when the carbon content is 0.04% or higher.

(a) For welding ends valves only. Flanged ends ratings terminate at 1000°F (538°C).

CAST STEEL ASTM A 351 GR CF8M

Temperature		Maximum allowable non-shock working pressure in PSIG by class		
°F	°C	150	300	600
-20 to 100	-29 to 38	275	720	1440
200	93	235	620	1240
300	149	215	560	1120
400	204	195	515	1025
500	260	170	480	955
600	316	140	450	900
650	343	125	440	885
700	371	110	435	870
750	399	95	425	855
800	427	80	420	745
850	454	65	420	735
900	482	50	415	730
950	510	35	385	775
1000	538	20	365	725
1050	566	20	360	720
1100	593	20(a)	305	610
1150	621	20(a)	235	475
1200	649	20(a)	185	370
1250	677	20(a)	145	295
1300	704	20(a)	115	235
1350	732	20(a)	95	190
1400	760	20(a)	75	150
1450	788	20(a)	60	115
1500	816	15(a)	40	85

Note:

* At temperatures over 1,000°F, use only when the carbon content is 0.04% or higher.

(a) For welding ends valves only. Flanged ends ratings terminate at 1000°F (538°C).

STAINLESS STEEL ASTM A 351 GR CF3 or GR CF3M

Temperature		Maximum allowable non-shock working pressure in PSIG by class		
°F	°C	150	300	600
-20 to 100	-29 to 38	230	600	1200
200	93	195	510	1020
300	149	175	455	910
400	204	160	420	840
500	260	150	395	785
600	316	140	370	745
650	343	125	365	730
700	371	110	360	720
750	399	110	355	705
800	427	80	345	690

LOW CARBON STAINLESS STEEL ASTM A 351 GR CG3M

Temperature		Maximum allowable non-shock working pressure in PSIG by class		
°F	°C	150	300	600
-20 to 100	-29 to 38	275	720	1440
200	93	235	620	1240
300	149	215	560	1120
400	204	195	515	1025
500	260	170	480	955
600	316	140	450	900
650	343	125	440	885
700	371	110	435	870
750	399	95	425	855
800	427	80	420	845
850	454	65	420	835

PRESSURE-TEMPERATURE RATINGS

SUPER DUPLEX STAINLESS STEEL ASTM A 995 GR 6A CD3MWCuN (S32750)

Temperature		Maximum allowable non-shock working pressure in PSIG by class		
°F	°C	150	300	600
-20 to 100	-29 to 38	290	750	1500
200	93	260	745	1490
300	149	230	665	1335
400	204	200	615	1230
500	260	170	580	1160
600	316	140	555	1115
650	343	125	545	1095
700	371	110	540	1085
750	399	95	530	1065

Note:

* This steel may become brittle after service at moderately elevated temperatures. Not to be used over 600°F.

STAINLESS STEEL ASTM A 351 GR CG8M

Temperature		Maximum allowable non-shock working pressure in PSIG by class		
°F	°C	150	300	600
-20 to 100	-29 to 38	275	720	1440
200	93	235	620	1240
300	149	215	560	1120
400	204	195	515	1025
500	260	170	480	955
600	316	140	450	900
650	343	125	440	885
700	371	110	435	870
750	399	95	425	855
800	427	80	420	845
850	454	65	420	835
900	482	50	415	830
950	510	35	385	775
1000	538	20	365	725

Note:

* This steel may become brittle after service at moderately elevated temperatures. Not to be used over 600°F.

DUPLEX STAINLESS STEEL ASTM A 995 GR 4A CD3MN (S31803)

Temperature		Maximum allowable non-shock working pressure in PSIG by class		
°F	°C	150	300	600
-20 to 100	-29 to 38	290	750	1500
200	93	260	745	1490
300	149	230	665	1335
400	204	200	615	1230
500	260	170	580	1160
600	316	140	555	1115
650	343	125	545	1095
700	371	110	540	1085
750	399	95	530	1065

STAINLESS STEEL ASTM A 351 GR CN7M (ALLOY 20)

Temperature		Maximum allowable non-shock working pressure in PSIG by class		
°F	°C	150	300	600
-20 to 100	-29 to 38	230	600	1200
200	93	200	520	1035
300	149	180	465	930
400	204	160	420	845
500	260	150	390	780
600	316	140	360	720

DESIGN BASIS

All of WALWORTH's Valve Designs, when applicable, follow one or more of the following standards.

API American Petroleum Institute
603 Corrosion-resistant, Bolted Bonnet Gate Valves – Flanged and Butt-welding Ends
598 Valve Inspections and Testing

ASME Standards ASME International (American Society of Mechanical Engineers)

B2.1 Pipe Threads
B16.5 Steel Pipe Flanges and Flanged Fittings
B16.10 Length of Ferrous Flanged and Welding End Valves
B16.25 Butt-Welding Ends
B18.2 Square and Hexagon Bolts and Nuts
B16.34 Valves - Flanged, Threaded and Welding Ends
B16.47 Large Diameter Steel Flanges

ASTM American Society for Testing and Materials

A-193 Alloy Steel and Stainless Steel Bolting Materials for High Temperature Service
A-351 Castings, Austenitic, for Pressure-Containing Parts
A-439 Austenitic Ductile Iron Castings

MSS Standars Manufactures Standardization Society of the Valve and Fittings

SP-25 Standard Marking System for Valves, Fittings, Flanges and Unions
SP-44 Steel Pipeline Flanges
SP-45 Bypass and Drain Connections
SP-47 Limiting Dimensions of Raised Face Flange Gaskets

NACE Standars National Association of Corrosion Engineers

NACE MR0175 Standard Material Requirements Sulfide Stress Cracking Resistant Metallic Materials for Oilfield Equipment

Boiler and pressure vessel code

Section II Part A Ferrous Material Specifications
Section II Part B Non Ferrous Material Specifications
Section II Part C Specifications for Welding Rods, Electrodes and Filler Metals
Section V Non Destructive Tests
Section VIII Boiler and Pressure Vessel Code for Unfired Pressure Vessels, Divisions 1 and 2
Section IX Welding Qualifications



HOW TO ORDER

WALWORTH valves are designed by a catalog figure number which describe their main characteristics. The valve identification system shown herein is intended to assist our customers in specifying the required valve(s) so that mistakes are avoided during manufacturing.

10"-S5202-RF-UT-WCB-GO-NACEMR01-75



SIZE (In)	TYPE OF VALVE & PRESSURE CLASS	ENDS	TRIM ARRANGEMENTS	BASE MATERIAL ASTM
2"	S5202= GATE 150 #	RF= RAISED FACE	18-8 = API No. 2	LOW CARBON AUSTENITIC STAINLESS STEELS:
2 1/2"	S5206= GATE 300 #	RTJ= RING TYPE JOINT	310 = API No. 3	ASTM A351-CF3 (18% Cr- 8% Ni- 0.03% C)
3"	S5232= GATE 600 #	WE=BUTTWELD	18-8smo = API No. 10	ASTM A351-CF3M (18% Cr-12%Ni-2%Mo-0.03%C)
4"	S5275= GLOBE 150 #		3HF = API No. 12	ASTM A351-CG3M (18% Cr-12%Ni-3%Mo-0.03%C)
5"	S5281= GLOBE 300 #		A20 = API No. 13	AUSTENITIC STAINLESS STEELS:
6"	S5295= GLOBE 600 #		A20H = API No. 14	ASTM A351-CF8 (18% Cr- 8% Ni- 0.08% C)
8"	S5341= SWING CHECK 150 #		NUC = 410 + NUCALLOY	ASTM A351-CF8M (18% Cr-12%Ni-2%Mo-0.08%C)
10"	S5344= SWING CHECK 300 #		4HF = 304+304+ST6	ASTM A351-CF10 (18% Cr-8%Ni-0.08%C)
12"	S5350= SWING CHECK 600 #		4HF+HF = 304+ST6+ST6	ASTM A351-CG8M (19% Cr-10%Ni-3%Mo-0.08%C)
14"			304L = 304L+304L+304L	ASTM A351-CF8C (18% Cr-10%Ni-Cb-0.08%C)
16"			1HF = 316+ST21+ST21	ASTM A351-CT15C (19%Cr-32%Ni-0.05 A 0.15%C)
18"			3HF+HF = 316+ST6+ST6	SUPER AUSTENITIC STAINLESS STEELS:
20"			3TC = 316/TC+TC+ST6 NOTE: TC = Tungsten Carbide.	ASTM A351-CK20 (25% Cr-20%Ni-0.04 A 0.2%C)
22"			316L = 316+316+316	ASTM A351-CN7M (28% Ni-19%Cr-Cu-Mo0.07%C)
24"			3LHF = 316L+316L+ST6	ASTM A351-CN3M (21%Cr-24.5%Ni-6.5%Mo)
			3HFL = 316L+ST6+ST6	ASTM A351-CN3MN (24%Ni-21%Cr-6%Mo-Cu-N-0.03%C)
			21HF = 317+ST6+ST6	ASTM A351 CD4MCu (25.5%Cr-5.5%Ni2%Mo)
			317 = 317+317+317	ASTM A351-CN2MCuN(.02C;19-23Cr;23-28Ni;4-5Mo;1-2Cu)
			317H = 317+317+ST6	LOW TEMPERATURE SERVICE CARBON STEELS:
			317LH = 317L+ST6+ST6	ASTM A352-LCB (0.03%C-0.6%Si-1%Mn)
			31L = 317L+317L+317L	ASTM A352-LCC (0.025%C-0.6%Si-1%Mn)
			317LS = 317L+317L+ST6	LOW TEMPERATURE SERVICE LOW ALLOY STEELS:
			2HF = 321+321+ST6	ASTM A352-LC2 (0.25%C-2.5%Ni-0.65%Mn)
			321F = 321+ST6+ST6	ASTM A352-LC3 (0.15%C-3.5%Ni-0.65%Mn)
			321 = 321+321+321	MARTENSITIC STAINLESS STEELS:
			347HF = 347+ ST6+ST6	ASTM A487-CA6NM (12.75%Cr-4%Ni-0.7%Mo)
			347 = 347+347+347	ASTM A487-CA15 (12.75%Cr-1%Ni-1%Mn)
			347 = 347+347+ST6	NICKEL ALLOYS:
			254HF = 31254+ST6+ST6	ASTM A494-M30C (67% Ni- 30% Cu)
			51H = 31803+ST6+ST6	ASTM A494-M35-1 (67% Ni- 30% Cu)
			31803H = 31803+31803+ST6	ASTM A494-CZ100 (95% Ni)
			T9 = 17-4pH+TRIBALLOY 900+ TRIBALLOY 900	ASTM A494-CY40 (75% Ni-15% Cr- 8% Fe)
			HC = Hc-276+Hc-276+Hc-276	ASTM A494-CW2M (61% Ni- 16% Mo-16% Cr)
			HCH = Hc-276+Hc-276+ST6	ASTM A494-N12MV (62% Ni- 28% Mo- 5% Fe)
			UOP = MONELK500+MONEL 400+MONEL 400	ASTM A494-CW12MW (56%Ni-18%Mo- 17%Cr-6% Fe)
			625 = INCONEL 625+INCONEL 625+INCONEL 625	ASTM A494-CW6M (56% Ni-19% Mo-18% Cr-2% Fe)
			625HF = INCONEL 625+ST6+ST6	ASTM A494-CU5MCuC (42%Ni-21.5%Cr-3%Mo-2.3%Cu)
			810T = INCOLOY 800H+INCOLOY 800H+INCOLOY 800H	ASTM A494-N7M (65% Ni- 28% Mo- 2% Fe)
			825 = INCOLOY 825+INCOLOY825+INCOLOY 825	ASTM A494-CW6MC (60%Ni-22%Cr-9%Mo-3.5%Cb)
			23HF = INCOLOY 825+ST6+ST6	DUPLEX STAINLESS STEELS:
			HB = HASTELLOY B2+HASTELLOB2+HASTELLOY B2	ASTM A351-CD7MCuN (20.5%Cr-29%Ni-2.5%Mo)

SUPPLEMENTARY REQUIREMENTS
GO = Gear operator
CW = Chainwheel operator
BS = Bare stem prepared for actuator
MOV = Motor operated valve
POV = Pneumatic operated valve
LD = Locking device
NACEMR-01-75
NACEMR-01-03
SP = Special Paint
SG = Special gasket
SPK = Special packing
VOC = Certification of volatile organic compounds
BP = By-Pass
LL = Live Load Packing
LR = Lantern Ring
LCW = Lever & Counter Weight
SE = Stem extensions
FS = Floor atands
XX = Additional requirements

NOTE: ADDITIONAL BASE MATERIALS & TRIMS ARE AVAILABLE UPON REQUEST.

ASTM A890 1A; CD4MCu (25.5%Cr-5.5%Ni-2%Mo)
ASTM A890 2A; CE8MN (24%Cr-9.5%Ni-4%Mo)
ASTM A890 3A (CD6MN) (25.5%Cr-5%Ni-2.25Mo)
ASTM A890 4A; CD3MN (22%Cr-5%Ni-3%Mo-N)

THE WALWORTH COMPANY GENERAL TERMS AND CONDITIONS

ACCEPTANCE: All quotations are for acceptance within 30 days from date of quotation unless extended in writing. In the event a purchase order is placed after this period of time. WALWORTH reserves the right to requote base prices of all valves offered. All orders and contracts are subject to credit approval and acceptance by WALWORTH.

FREIGHT: When prices are f.o.b. point of shipment no freight allowance, we will attempt to route shipments in the method which will result in the lowest cost unless otherwise instructed. All shipments will be freight charges collect except when stipulated on the purchase order, in which case the customer will be invoiced for all transportation charges. Delivery of material to a common carrier shall be considered to be delivery to Buyer and shall be at Buyer's risk thereafter. Claims of loss of or damage to material in transit shall be filed by the Buyer directly with the carrier.

PRICES: There will be added to all prices quoted sales, use, occupation or any other excise or similar tax which Seller may be required to pay or collect on in connection with the sale. Seller shall be established by Federal, State or other government regulation(s) with respect to the product(s) Topped by the order which shall be lower than the price(s) specified in the order.

ESCALATION TERMS: Prices shown in this price schedule reflect the costs in effect at the time of publication. These prices will remain firm on all products with a quoted delivery of twenty-six (26) weeks or less. On products which have a scheduled delivery of more than twenty-six (26) weeks, the goods will be invoiced based on the applicable price sheet in effect at the time of shipment. In no event will the invoiced price be less than the price originally quoted.

PURCHASED (motors, gearing, etc.) Prices are quoted on supplier price in effect at time of quotation. Actual invoice Price will be adjusted in accordance with the supplier's escalation policy.

SHIPMENTS: If for any reason the customer desires to delay shipments more than 30 days after manufacturing is complete or to place a hold or stop to the order during the manufacturing cycle, WALWORTH reserves the right to consider the order canceled and to invoke cancellation charges per the schedule below.

CANCELLATION: After order acceptance by WALWORTH, items or completed orders may be cancelled and buyer will be charged for work performed, based on the following schedule:

- Five (5%) percent of prices of stock items.
- Ten (10%) percent of price of stock items ordered in quantities which exceed normal inventory levels.
- Five (5%) percent of prices prior to drawing submittal on made-to-order items.
- 15% after drawing approval, but prior to the start of castings.
- 30% to 50% during casting cycle, depending on the state of completion.
- 55% to 75% during machining and assembly operations, depending on the state of completion.
- 100% after final assembly and test.

REMITTANCES: Remittances must be made to the address indicated on the invoice.

CREDIT TERMS: As quoted. Invoices on balances overdue will be subject to a service charge of one-and-one-half percent per month on such indebtedness.

DELIVERIES: Shipments and deliveries shall at all times be subject to the approval of Seller's Credit Department. If the Buyer shall fail to make any payments according to the terms of the contract, Seller may, in addition to and not in limitation of its other rights and remedies, at its option, cancel all or any part of Buyer's incomplete contracts with Seller or may defer shipments of deliveries under Buyer's contracts with Seller except upon receipt of satisfactory security or for cash shipment.

All schedules of shipments are estimated as closely as possible and Seller will use its best efforts to ship within the time scheduled but does not guarantee to do so. Schedules commence with the date Seller receives authorization to proceed with order, subject to the provisions of the next sentence. The order will not be released for manufacture until complete specifications and approved drawings (if drawing approval is required) are received at the plant of manufacture and the estimated schedule of shipment will commence with the date of such receipt.

Seller shall not be liable for any direct, indirect or consequential damage or loss caused by any delay in delivery, regardless of the cause of delay.

Without limiting the generality of the foregoing, Seller assumes no responsibility for delays in delivery resulting from fire, flood, accidents, riots, strikes, transportation delays, labor or material shortages, existing or future laws, acts of any governmental authority, or any other cause beyond Seller's control. Items offered from stock are subject to prior sale.

INSPECTION: Final inspection and acceptance of products must be made at the plant of manufacture, unless otherwise provided in the order and/or in agreed upon specifications. Prices do not include charges for special tests or inspections performed at the request of the Buyer unless called for in the order and/or in agreed upon specifications.

RETURNS: Permission in writing and return tagging instructions must be obtained from Seller before any goods returned for credit or adjustment will be acceptance. Where returned goods are accepted, a minimum charge of 25% of the invoice price will be made, plus freight from both directions and costs of reconditioning the material for resale as new.

WARRANTY: Seller will replace without charge or refund the purchase price of products manufactured by Seller which prove to be defective in the material or workmanship, provided in each case that the product is properly installed and used in the service for which Seller recommends it and a written claim specifying the alleged defect is presented to Seller shall in no event be responsible for (a) claims for labor, expenses or other damages occasioned by defective products or (b) for consequences or secondary damages. **WARRANTY STATED IN THIS PARAGRAPH IS IN LIEU OF ALL OTHER WARRANTIES, EITHER EXPRESSED OR IMPLIED. WITH RESPECT TO WARRANTIES THIS PARAGRAPH STATES BUYER'S EXCLUSIVE REMEDY AND SELLER'S EXCLUSIVE LIABILITY.**

DESIGN: Seller reserves the right to change design, materials or specifications without notice. There will be a charge for modifying an order after it has been entered when such change or modification results in additional engineering or clerical work for either WALWORTH or our suppliers.

MINIMUM CHARGE: Orders totaling less than \$100.00 net will be billed at a minimum charge of \$100.00. Repair parts will be billed at a minimum charge of \$50.00.

NOTE: We reserve the right to correct obvious clerical errors in quotes, invoices, and other contracts.



WALWORTH®

Since 1842



www.walworth.com

MÉXICO

Industrial de Válvulas, S.A. de C.V.

Industria Lote 16 Sin Número, Fracc. Industrial El Trébol De Tepetzotlán, Tepetzotlán Estado de México C.P. 54610
Phone: (52 55) 5899 1700 Fax: (52 55) 5876 0156 | e-mail: info@walworth.com.mx

USA/CAN AUTHORIZED DISTRIBUTOR

TWC The Valve Company

13641 Dublin Court, Stafford, Texas 77477 | Phone: (281) 566 1200 Fax: (281) 566 1299 |
www.twcvalves.com | e-mail: info@twcousa.com



Scan me with your smartphone to get more info about **WALWORTH** valves

