

Rotary Tight Shut-Off Valves Type MAK

Triple Off-Set Design

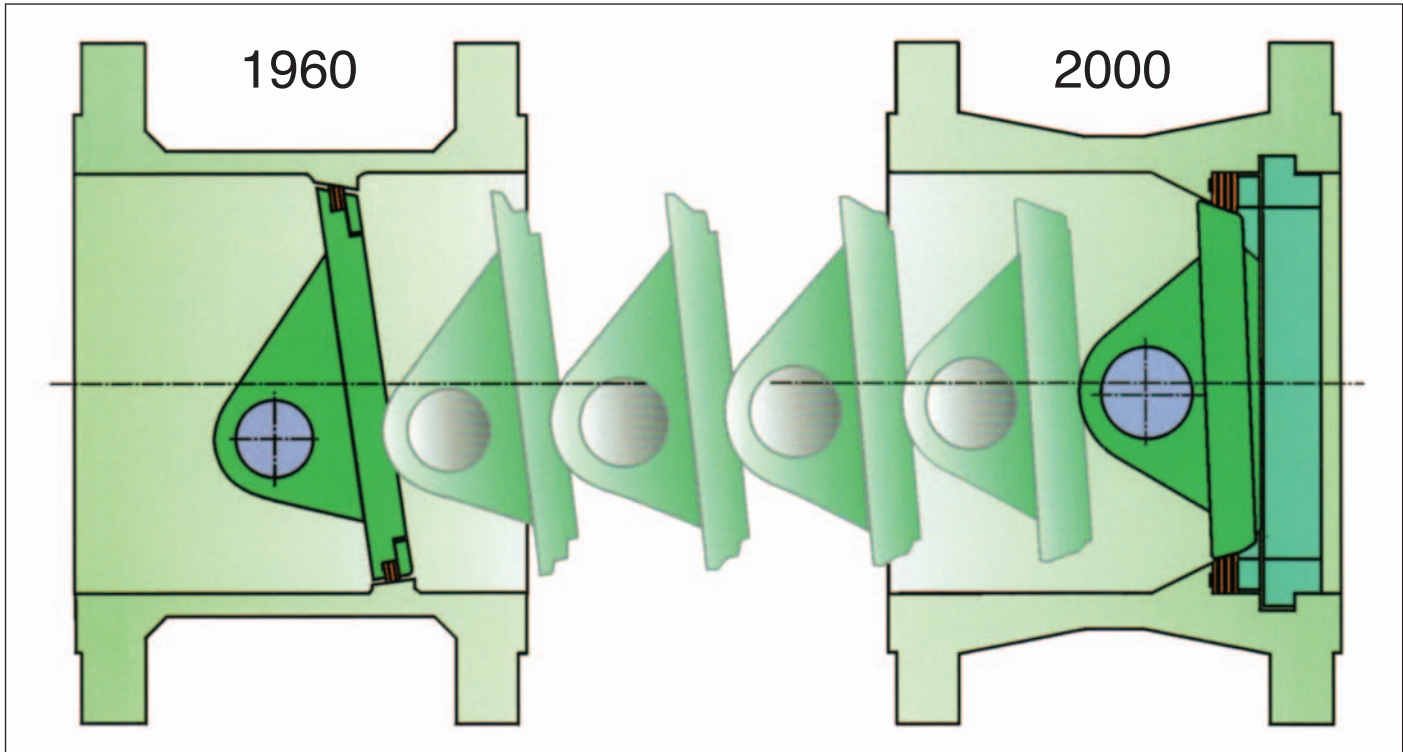

ADAMS created the Inclined Conical Sealing System and remains the leader in Rotary Tight Shut-Off Valve Technology

ADAMS valves, designed for critical requirements, have proven their reliability and efficiency since 1960 in a wide range of applications throughout the world.

The manufacturing range includes sizes from 80 mm / 3 inches to 3600 mm / 144 inches, operating temperatures from -196°C / -320°F to 950°C / 1742°F, and pressure ratings up to 400bar / 6000 psi.

ADAMS valves are designed to comply with accepted international standards: ANSI, API, ASME, MSS, DIN/EN/ISO, BS, AFNOR, GOST, etc.

A variety of materials allow tailored construction and complete adaptability to meet customers' requirements.





Rotary Tight Shut-Off Valve – MAK

Rotary valve technology, with metal-to-metal torque seating, offers exceptional performance, durability and reliability. Our valves have proven their longevity in the most critical applications, under extreme working conditions and millions of cycles.

When comparing to gate, plug, ball or position seated conventional butterfly valves, you will discover the “low cost of ownership” benefits of the MAK over the life of your system.

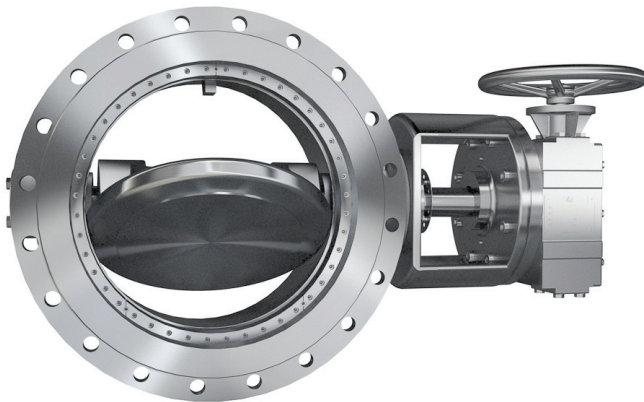

Technical Features MAK

- Metal-to-Metal Torque Seating
- Symmetrical Seal Ring in Body
- Triple eccentric Sealing
- Flanged or Butt-Weld Construction
- Body Length to: DIN EN 558 and ISO 5752 Series 13 + 14, ASME B 16.10, API 609
- Inherently Fire-Safe
- Low Fugitive Emissions
- German “TA-Luft”-Specification
- Compact Size / Low Weight
- Save Piping Space
- Reduced Piping Loads
- Reduced Installation Cost
- Stable Control Characteristics
- Replaceable internal parts
- Bi-Directional
- Zero Leakage

Design

Nominal Diameters:

80 mm / 3 inches to 2000 mm / 80 inches

Temperature Range:

Laminated Seal:

-196°C / -320°F to 500°C / 932°F

Solid Seal:

-46°C / -50°F to 600°C / 1112°F

Pressure Class:

ASME 150/300/600/900

PN 10/16/25/40/64/100

Actuator Options:

Manual Gear, Pneumatic, Electric, Hydraulic



The ADAMS MAK Sealing System

Due to the **Unique Seat Geometry**, the disc moves without any jamming even at High Temperature Differentials and under Full Rated Pressure.

In the closed position, **torque applied to the shaft is transferred by keyed- or splined-connection to the disc** which is firmly pressed against the seal ring.

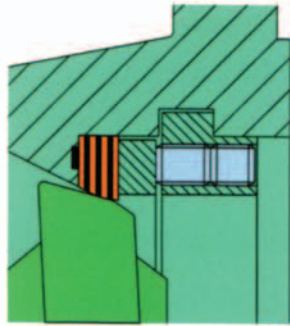

With the **laminated seal ring** held statically in place, **no flexing or movement** occurs. This rugged system produces high sealing loads, **without rubbing**, assuring the most dependable **zero-leakage** shut-off in critical applications.

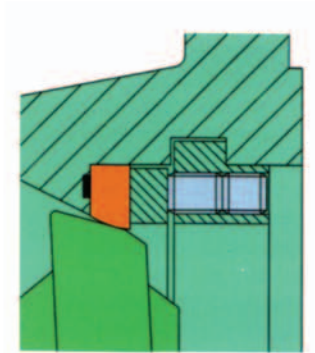
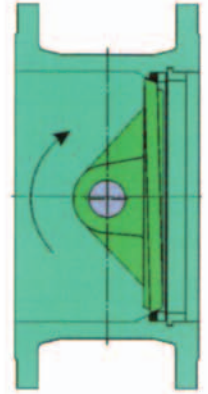

A **solid metal sealing ring** provides positive shut-off capability at **high temperatures** and with **abrasive media**.

With no contact between seal and disc throughout the travel, the valve is now in the full open position. The MAK shaft is supported by **extremely robust and highly engineered bearings** which provide a long trouble-free life.

An important aspect of the MAK's rotary motion and packing is the control of **fugitive emissions**.

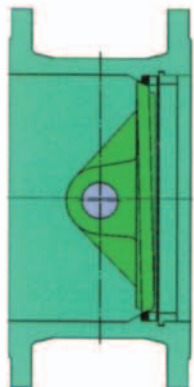
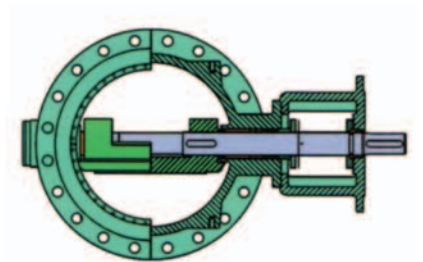

The ultimate advantage of the MAK is its zero leakage, bi-directional shut-off in gases, steam and liquids even when particulates are present. Its metal-to-metal sealing system, and the protected seal in the body, combining patented technology with conservatively engineered design, provides critical **bi-directional** shut-off in the most aggressive and challenging applications.

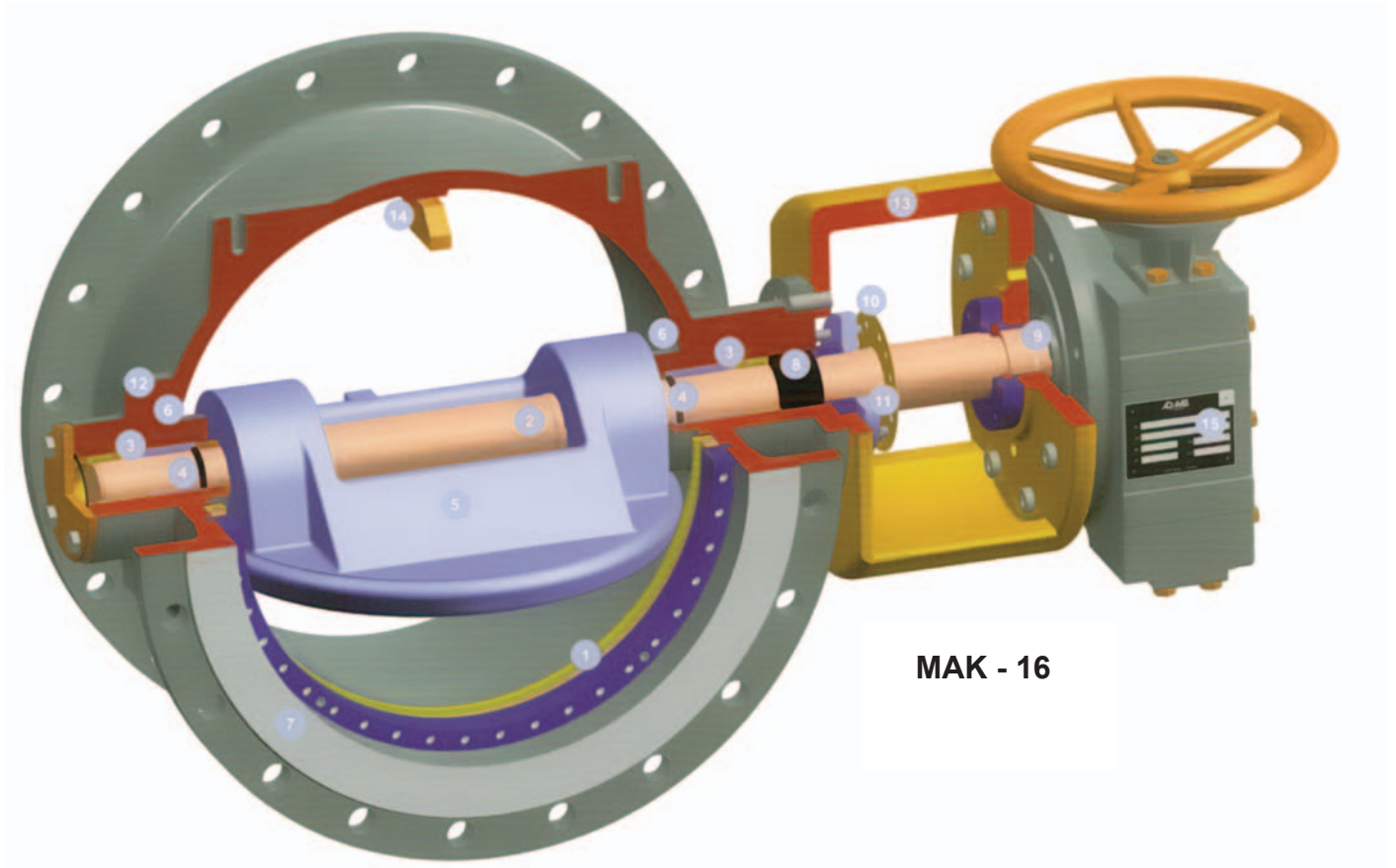

MAK - 16

Features

1. Unique field-replaceable seal system in body
2. Keyed or splined disc-to-shaft connection
3. Robust top and bottom shaft bearings
4. Energized bearing protectors
5. Rigid disc design minimizes deflection
6. Extended body hubs
7. Full face flanges
8. Emission tight packing system
9. External blowout prevention and bearing system
10. External valve position indication
11. Self-centering packing gland (four studs minimum)
12. Integrally cast purge / grease port bosses
13. Heavy duty cast operator mounting bracket rigidly pinned and registered to body
14. Disc over-travel stop (safety feature)
15. Manual operators specifically engineered

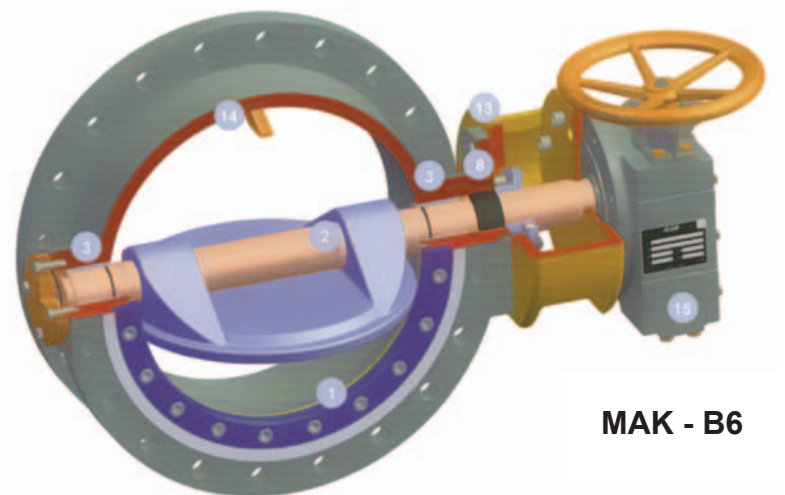

MAK - B6

Optional Configurations MAK - 16

The following options are available for applications requiring modification from our “standard design”. Please consult factory for further information.

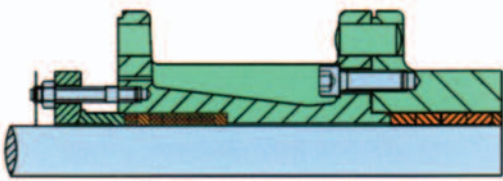

Cryogenic Extension

- Liquefied Natural Gas Plants
- Air Separation
- to -196°C / -320°F

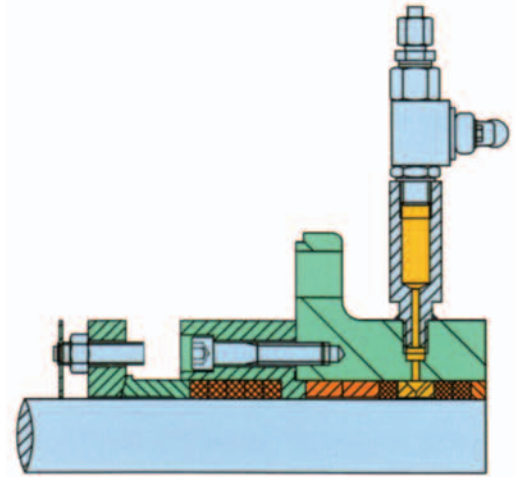

Safety Packing

- Change Primary Packing with Valve in Service

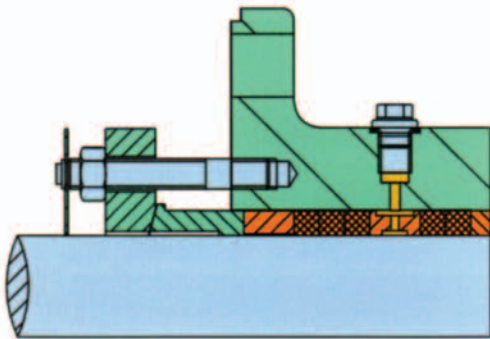

Lantern Ring and Purge Systems

- For Special Shaft Sealing Applications

Additional Options

- Body Jacketing (Heating / Cooling)
- Special Cleaning Options
- Disc Edge Protection
- NACE Design
- Hard-Facing of Disc or Shaft
- High Temperature Extensions
- Out-Board Bearings
- Shaft Steam Tracing
- Top Entry / Access Port for In-Line Maintenance

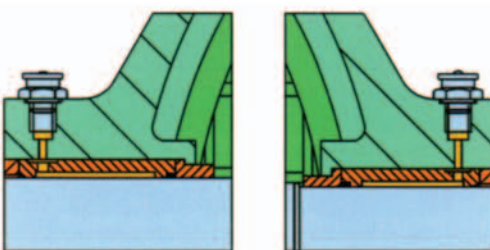

Lubricated Bearings

- Media with High Particulate Content
- Ultra-High Cycle Applications

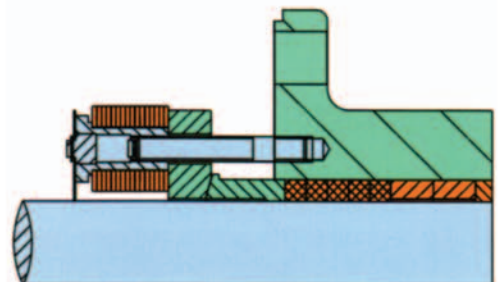

Live Loaded Packing

- Extended Maintenance Cycle

Applications in:

- District Heating
- Steam Distribution
- Refining and Petrochemical
- Power Generation
- Chemical
- Liquefied Natural Gas
- Steel Making
- Pulp and Paper
- Water Works

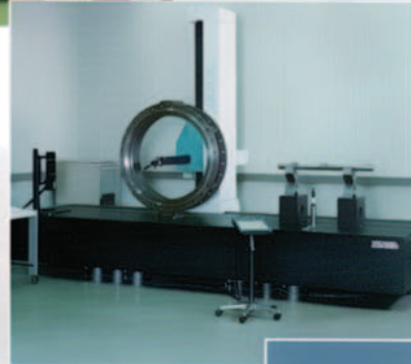
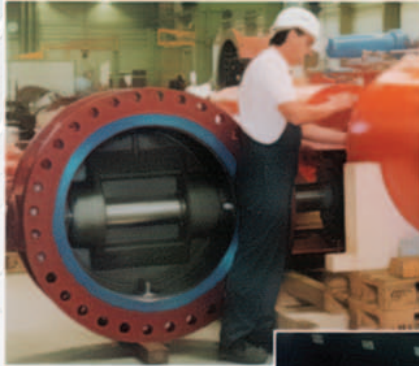

Uncompromising Quality

Our highly qualified staff and facilities guarantee ADAMS' consistent high production standards. An expert team of experienced mobile service personnel is available for on-site staff training and servicing during regular plant maintenance.

During the complete manufacturing process all valves and their components are subjected to stringent quality surveillance. A continuous improvement program includes quality planning, quality control, monitoring, intensive personnel training, regular internal audits, and external suppliers' audits.

Ongoing optimization ensures that all products meet the highest standards.

The ADAMS' quality assurance system also meets the extended requirements of German KTA-rule 1401 as well as other nuclear requirements.